

Design of State Variable Feedback Systems

This chapter deals with the design of controllers utilizing state feedback. We will consider three major subjects: Controllability and observability and then the procedure for determining an optimal control system. Ackermann's formula can be used to determine the state variable feedback gain matrix to place the system poles at the desired locations. The closed-loop system pole locations can be arbitrarily placed if and only if the system is controllable.

When the full state is not available for feedback, we utilize an observer. The observer design process is described and the applicability of Ackermann's formula is established. The state variable compensator is obtained by connecting the full-state feedback law to the observer.

We consider optimal control system design and then describe the use of internal model design to achieve prescribed steady-state response to selected input commands.

Pole Placement Using State Feedback

- The state-space design method is based on the pole-placement method and the quadratic optimal regulator method. The pole placement method is similar to the root-locus method. In that we place closed-loop poles at desired locations. The basic difference is that in the root-locus design we place only the dominant closed loop poles at the desired locations, while in the pole-placement method we place all closed-loop poles at desired locations.
- The state variable feedback may be used to achieve the desired pole locations of the closed-loop transfer function $T(s)$.
- The approach is based on the feedback of all the state variables, and therefore $u = Kx$.
- When using this state variable feedback, the roots of the characteristic equation are placed where the transient performance meets the desired response.

State Variable Compensator Employing Full-State Feedback in Series with a Full State Observer

$$\dot{\mathbf{x}} = \mathbf{A}\mathbf{x} + \mathbf{B}u$$

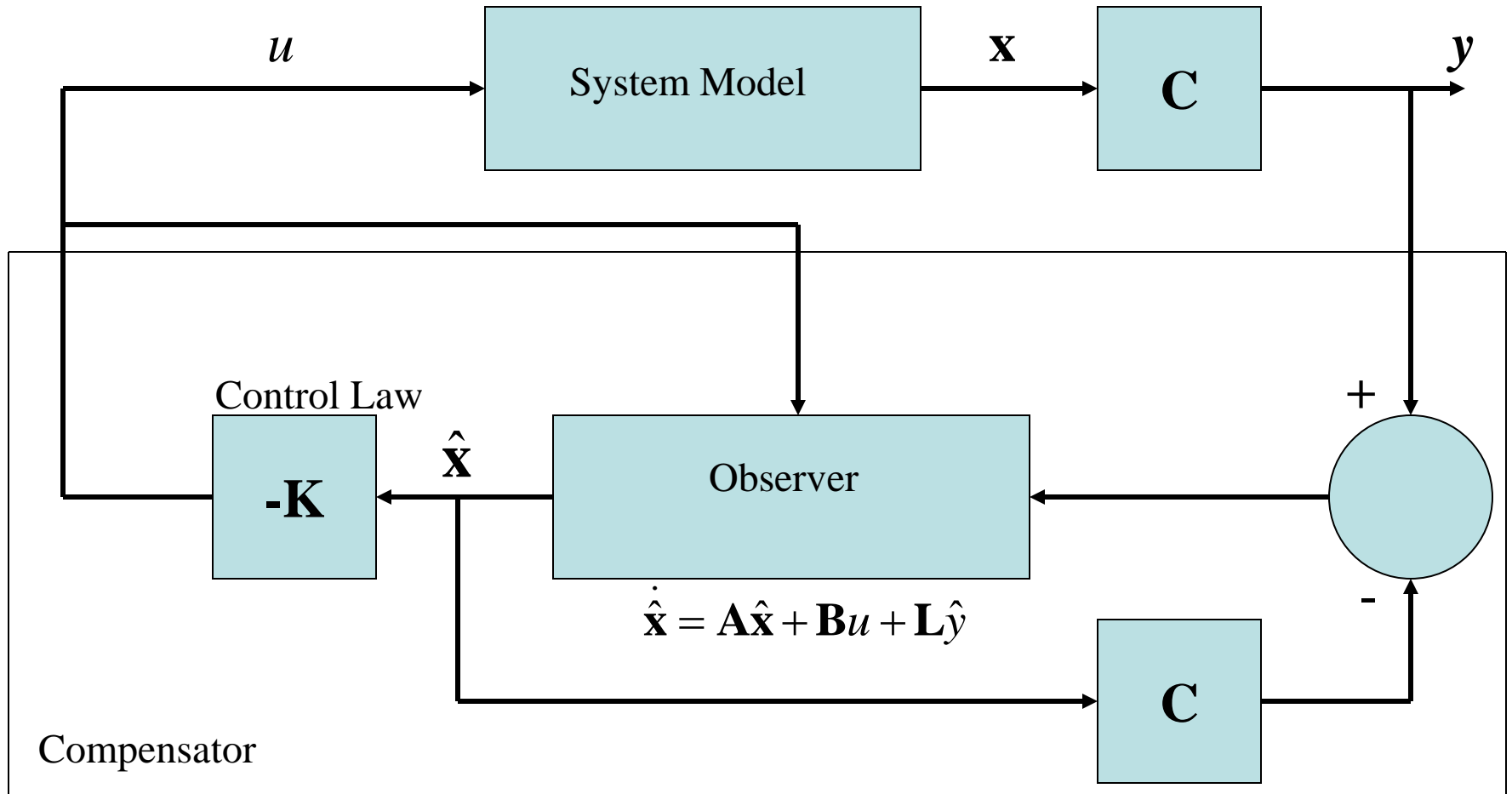

Controllability and Observability

- The concept of controllability and observability were introduced by Kalman in 1960.
- They play an important role in the design of control systems in state space.
- The conditions of controllability and observability may govern the existence of a complete solution to the control system design problem.
- The solution of the problem may not exist if the system is not controllable.

Controllability

- A system described by the matrices (A, B) can be said to be controllable if there exists an **unconstrained** control u that can transfer any initial state x(0) to any other desired location x(t). That means that over time, some or all of the scalar time functions in u can be arbitrarily large in magnitude.

$$\dot{\mathbf{x}} = \mathbf{A}\mathbf{x} + \mathbf{B}u$$

$$\mathbf{P}_c = \begin{bmatrix} \mathbf{B} & \mathbf{A}\mathbf{B} & \mathbf{A}^2\mathbf{B} & \dots & \mathbf{A}^{n-1}\mathbf{B} \end{bmatrix} \text{ (Controllability matrix P)}$$

If \mathbf{P}_c is nonzero, the system is controllable

- Another method of determining whether a system is controllable is to draw the state variable flow diagram and determine whether the control signal, u, has a path to each state variable. If a path to each state exists, the system may be controllable.

Example of a Controllable system!

$$\frac{Y(s)}{U(s)} = T(s) = \frac{1}{s^3 + a_2s^2 + a_1s + a_0}$$

$$\dot{\mathbf{x}} = \begin{bmatrix} 0 & 1 & 0 \\ 0 & 0 & 1 \\ -a_0 & -a_1 & -a_2 \end{bmatrix} \mathbf{x} + \begin{bmatrix} 0 \\ 0 \\ 1 \end{bmatrix} u$$

$$\mathbf{B} = \begin{bmatrix} 0 \\ 0 \\ 1 \end{bmatrix}, \quad \mathbf{AB} = \begin{bmatrix} 0 \\ 1 \\ -a_2 \end{bmatrix}, \quad \mathbf{A}^2\mathbf{B} = \begin{bmatrix} 1 \\ -a_2 \\ (a_2^2 - a_1) \end{bmatrix}$$

$$\mathbf{P}_c = \begin{bmatrix} 0 & 0 & 1 \\ 0 & 1 & -a_2 \\ 1 & -a_2 & (a_2^2 - a_1) \end{bmatrix} \quad \text{Determinant of } \mathbf{P}_c \text{ is nonzero}$$

Continue..

- Uncontrollable system has a subsystem that is physically disconnected from the input.
- For a partially controllable system, if the uncontrollable modes are stable and the unstable modes are controllable, the system is said to be stabilized. For example such system

$$\begin{bmatrix} \dot{x}_1 \\ \dot{x}_2 \end{bmatrix} = \begin{bmatrix} 1 & 0 \\ 0 & -1 \end{bmatrix} \begin{bmatrix} x_1 \\ x_2 \end{bmatrix} + \begin{bmatrix} 1 \\ 0 \end{bmatrix} u$$

- Is not controllable. The stable mode that corresponds to the eigenvalue of -1 is not controllable. The unstable mode that corresponds to the eigenvalue of 1 is controllable. Such a system can be made stable by the use of a suitable feedback. Therefore the system is stabilizable.

Observability

- All the roots of the characteristic equation can be placed where desired in the s-plane if, and only if, a system is **observable and controllable**.
- Observability refers to the ability to estimate a state variable. Thus we say a system may be observable if the output has a component due to each state variable.
- A system is observable if, and only if, there exists a finite time T such that the initial state $x(t)$ can be determined from the observation history $y(t)$ given the control $u(t)$. Consider the single-input, single-output system

$$\dot{x} = Ax + Bu \quad \text{and} \quad y = Cx$$

This system is observable when the determinant of Q is nonzero, where

$$Q = \begin{bmatrix} C \\ CA \\ \dots \\ CA^{n-1} \end{bmatrix}$$

Example of Observable System!

$$A = \begin{bmatrix} 0 & 1 & 0 \\ 0 & 0 & 1 \\ -a_0 & -a_1 & -a_2 \end{bmatrix} \text{ and } C = [1 \ 0 \ 0]$$

$$CA = [0 \ 1 \ 0] \text{ and } CA^2 = [0 \ 0 \ 1]$$

$$Q = \begin{bmatrix} 1 & 0 & 0 \\ 0 & 1 & 0 \\ 0 & 0 & 1 \end{bmatrix}, \text{ Det } Q = 1, \text{ and the system is observable!}$$

Is this System Controllable and Observable?

$$\begin{bmatrix} \dot{x}_1 \\ \dot{x}_2 \end{bmatrix} = \begin{bmatrix} 1 & 1 \\ -2 & -1 \end{bmatrix} \begin{bmatrix} x_1 \\ x_2 \end{bmatrix} + \begin{bmatrix} 0 \\ 1 \end{bmatrix} u$$

$$y = \begin{bmatrix} 1 & 0 \end{bmatrix} \begin{bmatrix} x_1 \\ x_2 \end{bmatrix}$$

Since the rank of the matrix $[\mathbf{B} \quad \mathbf{AB}] = \begin{bmatrix} 0 & 1 \\ 1 & -1 \end{bmatrix}$ is 2,

the system is fully state controllable

To test the observability condition, examine the rank of $[\mathbf{C} \quad \mathbf{AC}] = \begin{bmatrix} 1 & 1 \\ 0 & 1 \end{bmatrix}$ is 2,

the system is observable

Full-State Feedback Control System

to achieve the desired pole locations of the closed loop system

First we should assume that all the states are available for feedback

The system input $u(t)$ is given by

$$u = -Kx$$

Determining the gain matrix K is the objective of the full-state feedback design procedure

$$\dot{\mathbf{x}} = \mathbf{A}\mathbf{x} + \mathbf{B}u$$

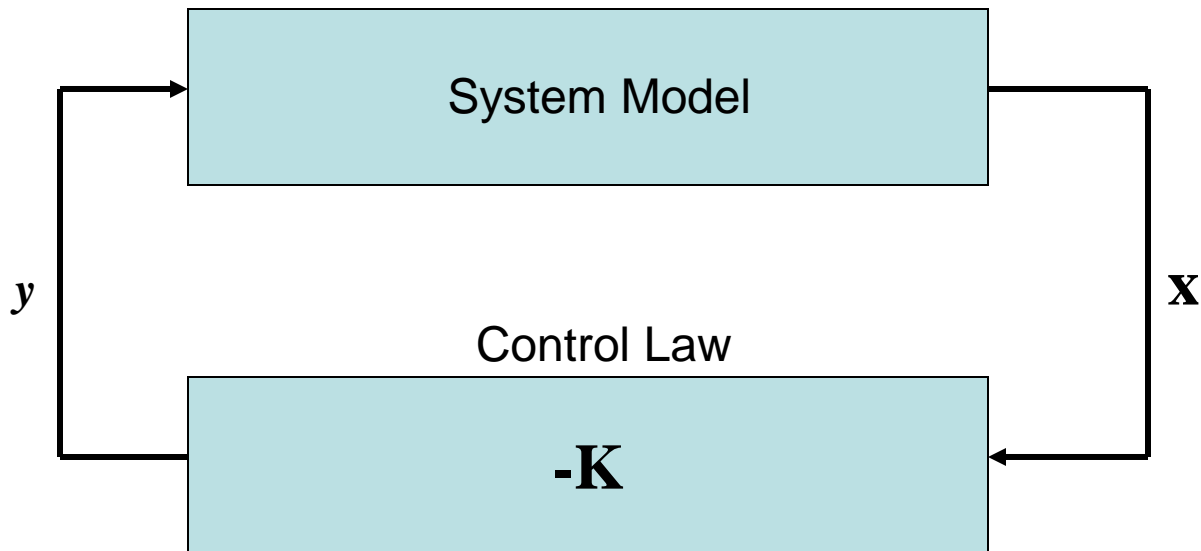

Compensator Design

Integrated Full-State Feedback and Observer

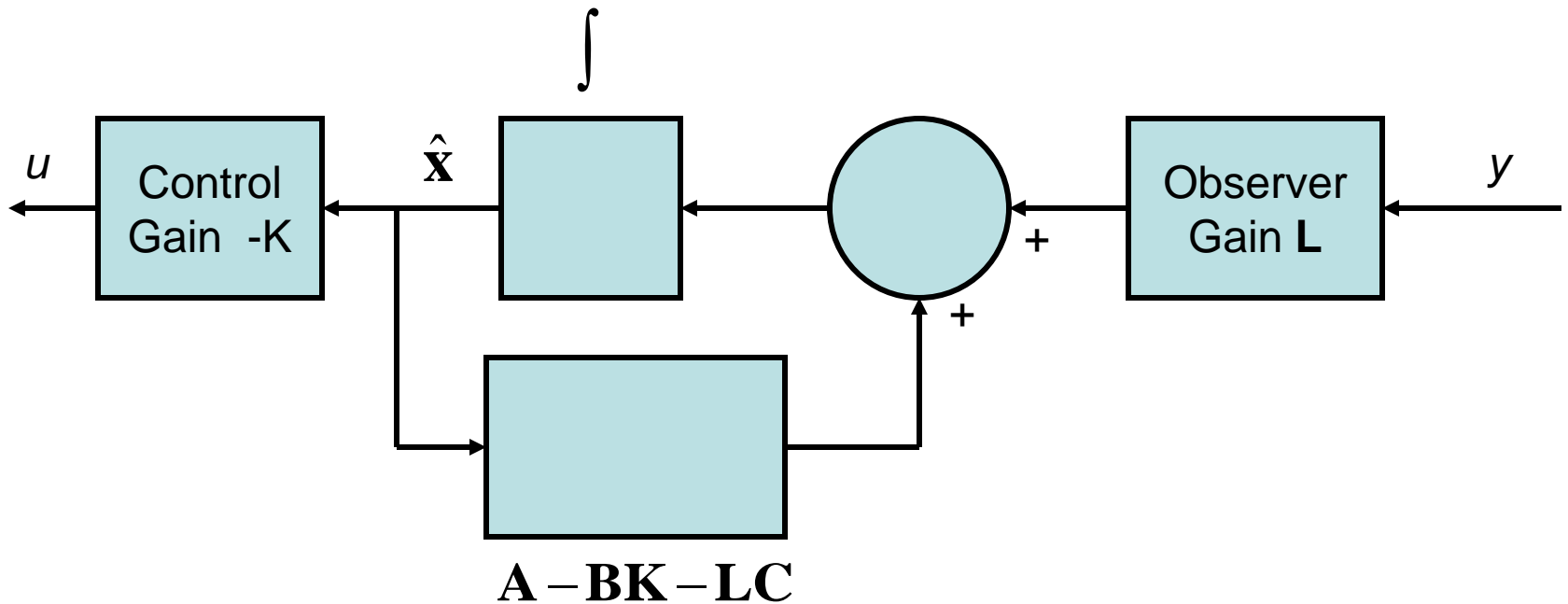

$u(t) = -\mathbf{K}\hat{\mathbf{x}}(t)$ Feedback Law

Employ state estimate $\hat{\mathbf{x}}(t)$ in the feedback control in place of $\mathbf{x}(t)$

$\text{Det}(s\mathbf{I} - (\mathbf{A} - \mathbf{BK})) = 0$ From full - state feedback. We need to verify that when using the feedback control law we retain the stability

$\dot{\hat{\mathbf{x}}} = \mathbf{A}\hat{\mathbf{x}} + \mathbf{B}u + \mathbf{L}(y - \mathbf{C}\hat{\mathbf{x}})$ (From the observer, see the previous lecture)

$\dot{\hat{\mathbf{x}}} = (\mathbf{A} - \mathbf{BK} - \mathbf{LC})\hat{\mathbf{x}} + \mathbf{L}y$

$u = -\mathbf{K}\hat{\mathbf{x}}$

$\dot{\mathbf{e}} = \dot{\mathbf{x}} - \dot{\hat{\mathbf{x}}} = \mathbf{A}\mathbf{x} + \mathbf{B}u - \mathbf{A}\hat{\mathbf{x}} - \mathbf{B}u - \mathbf{L}y + \mathbf{LC}\hat{\mathbf{x}}$ (time derivative of estimation error)

$\dot{\mathbf{e}} = (\mathbf{A} - \mathbf{LC})\mathbf{e}$

$\dot{\mathbf{x}} = \mathbf{A}\mathbf{x} + \mathbf{B}u; y = \mathbf{C}\mathbf{x}$

$\dot{\mathbf{x}} = \mathbf{A}\mathbf{x} + \mathbf{B}u = \mathbf{A}\mathbf{x} - \mathbf{BK}\hat{\mathbf{x}}; \quad \hat{\mathbf{x}} = \mathbf{x} - \mathbf{e}$

$\dot{\mathbf{x}} = (\mathbf{A} - \mathbf{BK})\mathbf{x} + \mathbf{BK}\mathbf{e}$

$$\begin{pmatrix} \dot{\mathbf{x}} \\ \dot{\mathbf{e}} \end{pmatrix} = \begin{bmatrix} \mathbf{A} - \mathbf{BK} & \mathbf{BK} \\ \mathbf{0} & \mathbf{A} - \mathbf{LC} \end{bmatrix} \begin{pmatrix} \mathbf{x} \\ \mathbf{e} \end{pmatrix}$$

The closed-loop system has no input. The objective is to maintain zero output. Because of disturbances the output will deviate from zero. The nonzero output will be returned to zero reference input because of the state feedback scheme.

$$\dot{\mathbf{x}} = \mathbf{A}\mathbf{x} + \mathbf{B}u; \quad u = -\mathbf{K}\mathbf{x}$$

$$\dot{\mathbf{x}} = \mathbf{A}\mathbf{x} + \mathbf{B}u = \mathbf{A}\mathbf{x} - \mathbf{B}\mathbf{K}\mathbf{x} = (\mathbf{A} - \mathbf{B}\mathbf{K})\mathbf{x}$$

$$\det(\lambda\mathbf{I} - (\mathbf{A} - \mathbf{B}\mathbf{K})) = 0$$

If all the roots of the characteristic equation lie in the left half - plane then the closed loop system is stable.

$$\mathbf{x}(t) = e^{(\mathbf{A} - \mathbf{B}\mathbf{K})t} \mathbf{x}(t_0) \rightarrow 0 \text{ as } t \rightarrow \infty$$

Given the pair (\mathbf{A}, \mathbf{B}) , we can determine \mathbf{K} to place all the system closed loop poles in the left half plane if the system is completely controllable.

The addition of a reference input can be considered as $u(t) = -\mathbf{K}\mathbf{x}(t) + Nr(t)$ where $r(t)$ is the reference input.

When $r(t) = 0$ for all $t > t_0$ the control design problem is **regular**

The goal is to verify that, with the value of $u(t)$ we retain the stability of the closed-loop system and the observer. The characteristic equation associated with the previous equation is

$$\Delta(s) = \text{Det}(s\mathbf{I} - (\mathbf{A} - \mathbf{BK})) \text{Det}(s\mathbf{I} - (\mathbf{A} - \mathbf{LC}))$$

So if the roots of both parts of the above equation (first related to full - state feedback law and second to the design of the observer, then the overall system is stable.

Design Procedure

1. Determine \mathbf{K} such that $\text{Det}(s\mathbf{I} - (\mathbf{A} - \mathbf{BK})) = 0$ has roots in the left half plane and place the roots properly to meet the design criteria.
2. Determine \mathbf{L} such that $\text{Det}(s\mathbf{I} - (\mathbf{A} - \mathbf{LC})) = 0$ has roots in the left half plane and place the roots to achieve observer performance.
3. Connect the observer to the full - state feedback law using $u(t) = -\mathbf{K}\hat{\mathbf{x}}(t)$

Design of a Third Order System

$$\frac{d^3 y}{dt^3} + 5 \frac{d^2 y}{dt^2} + 3 \frac{dy}{dt} + 2y = u$$

Select the state variables as : $x_1 = y; x_2 = dy/dt; x_3 = d^2 y/dt^2$

$$\dot{x} = \begin{bmatrix} 0 & 1 & 0 \\ 0 & 0 & 1 \\ -2 & -3 & -5 \end{bmatrix} x + \begin{bmatrix} 0 \\ 0 \\ 1 \end{bmatrix} u = Ax + Bu$$

If the state variable feedback matrix K is : $K = [k_1 \quad k_2 \quad k_3]$ and $u = -Kx$

$\dot{x} = Ax - BKx = (A - BK)x$; The state feedback matrix is

$$[A - BK] = \begin{bmatrix} 0 & 1 & 0 \\ 0 & 0 & 1 \\ (-2 - k_1) & (-3 - k_2) & (-5 - k_3) \end{bmatrix}$$

The characteristic equation is $\text{Det}[A - BK] = s^3 + (5 + k_3)s^2 + (3 + k_2)s + (2 + k_1)$

Chose the desired characteristic equation : $(s^2 + 2\xi\omega_n s + \omega_n^2)(s + \xi\omega_n)$;

Chose $\xi = 0.8$ for minimal overshoot. If we want a settling time equal to 1s, then

$$T_s = \frac{4}{\xi\omega_n} = \frac{4}{0.8\omega_n} \cong 1; \text{ If we chose } \omega_n = 6, \text{ then we have}$$

$$(s^2 + 9.6s + 36)(s + 4.8) = s^3 + 14.4s^2 + 82.1s + 172.8$$

Then we require $k_1 = 9.4; k_2 = 79.1; k_3 = 170.8$

The step response has no overshoot

Ackermann's Formula

For a single-input, single-output system, Ackermann's formula is useful for determining the state variable feedback matrix

$$\mathbf{K} = [k_1 \ k_2 \ \dots \ k_n]$$

$$u = -\mathbf{K}\mathbf{x}$$

Given the desired characteristic equation

$$q(\lambda) = \lambda^n + \alpha_1 \lambda^{n-1} + \dots + \alpha_n$$

The state feedback gain matrix is

$$\mathbf{K} = [0 \ 0 \ \dots \ 1] \mathbf{P}_c^{-1} q(\mathbf{A})$$

$$q(\mathbf{A}) = \mathbf{A}^n + \alpha_1 \mathbf{A}^{n-1} + \dots + \alpha_{n-1} \mathbf{A} + \alpha_n \mathbf{I}$$

Observer Design

If the system is completely observable with a given set of outputs, then it is possible to determine or estimate the states that are not directly measured

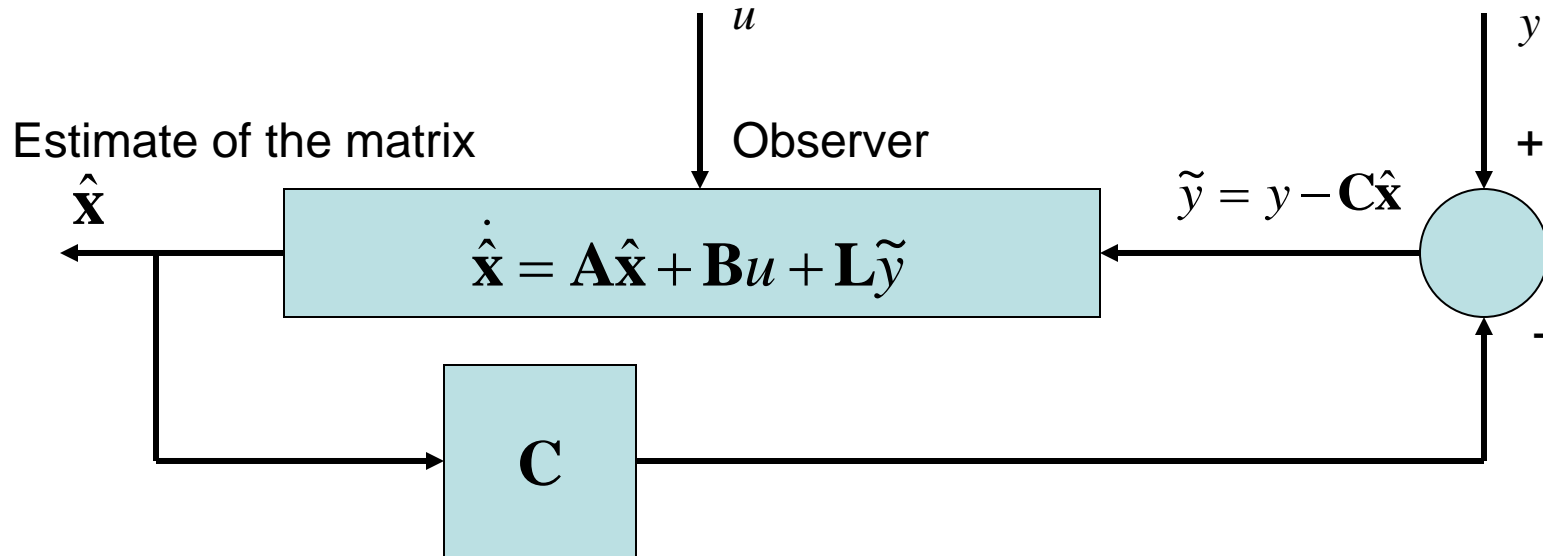

\mathbf{L} is the observer gain matrix and to be determined

The goal of the observer is to provide an estimate $\hat{\mathbf{x}}$ so that $\hat{\mathbf{x}} \rightarrow \mathbf{x}$ as $t \rightarrow \infty$.

We do not know $\mathbf{x}(t_0)$ precisely; we should provide an initial estimate $\hat{\mathbf{x}}(t_0)$ to the observer. The observer estimation error is $\mathbf{e}(t) = \mathbf{x}(t) - \hat{\mathbf{x}}(t)$. The observer design should produce $\mathbf{e}(t) \rightarrow 0$ as $t \rightarrow \infty$.

Take the time derivative of the estimation error of the previous equation

$$\dot{\mathbf{e}} = \dot{\mathbf{x}} - \dot{\hat{\mathbf{x}}}$$

$$\dot{\hat{\mathbf{x}}} = \mathbf{A}\mathbf{x} + \mathbf{B}u + \mathbf{L}(y - \mathbf{C}\hat{\mathbf{x}})$$

$$\dot{\mathbf{e}} = \mathbf{A}\mathbf{x} + \mathbf{B}u - \mathbf{A}\hat{\mathbf{x}} - \mathbf{B}u - \mathbf{L}(y - \mathbf{C}\hat{\mathbf{x}})$$

$$\dot{\mathbf{e}}(t) = (\mathbf{A} - \mathbf{L}\mathbf{C})\mathbf{e}(t)$$

$$\mathbf{e}(t) \rightarrow 0 \text{ as } t \rightarrow \infty \text{ as } \text{Det}(\lambda\mathbf{I} - (\mathbf{A} - \mathbf{L}\mathbf{C})) = 0$$

has its all roots in the left half plane.

E11.3: A system is described by the matrix equation. Determine whether the system is controllable and observable.

$$\dot{\mathbf{x}} = \begin{bmatrix} 0 & 1 \\ 0 & -3 \end{bmatrix} \mathbf{x} + \begin{bmatrix} 0 \\ 1 \end{bmatrix} u; \quad y = 2x_2$$

$$P_c = [\mathbf{B} \quad \mathbf{AB}] = \begin{bmatrix} 0 & 1 \\ 1 & -3 \end{bmatrix}$$

Since P_c is not equal to zero, the system is controllable.

The observability matrix is

$$Q = \begin{bmatrix} \mathbf{C} \\ \mathbf{CA} \end{bmatrix} = \begin{bmatrix} 0 & 2 \\ 0 & -6 \end{bmatrix}$$

Since $\text{Det } Q$ is equal to zero, therefore the system is unobservable!

E11.4: A system is described by the matrix equation. Determine whether the system is controllable and observable.

$$\dot{\mathbf{x}} = \begin{bmatrix} -4 & 0 \\ 0 & -1 \end{bmatrix} \mathbf{x} + \begin{bmatrix} 0 \\ 1 \end{bmatrix} u; \text{ and } y = x_1$$

First find the controllability matrix

$$\mathbf{P}_c = [\mathbf{A} \quad \mathbf{AB}] = \begin{bmatrix} 0 & 0 \\ 1 & -1 \end{bmatrix}$$

Since $\text{Det } \mathbf{P}_c = 0$, the system is uncontrollable.

The observability matrix is

$$\mathbf{Q} = \begin{bmatrix} \mathbf{C} \\ \mathbf{CA} \end{bmatrix} = \begin{bmatrix} 1 & 0 \\ -4 & 0 \end{bmatrix}$$

Since $\text{Det } \mathbf{Q} = 0$, the system is unobservable.