

# Linear and Non Linear Electronics Class 1 – 02/12/2011

ELG4139  
Julio Pimentel  
Kylowave Inc.

# Class 1

## What you will learn

- Introduction on PWM modulators
- Introduction on three-phase inverters
- Fundamentals of Brushless DC motors
- Operation of BLDC motors using six-steps control algorithm
- Speed and torque control of BLDC motors

# A BLDCM Control System

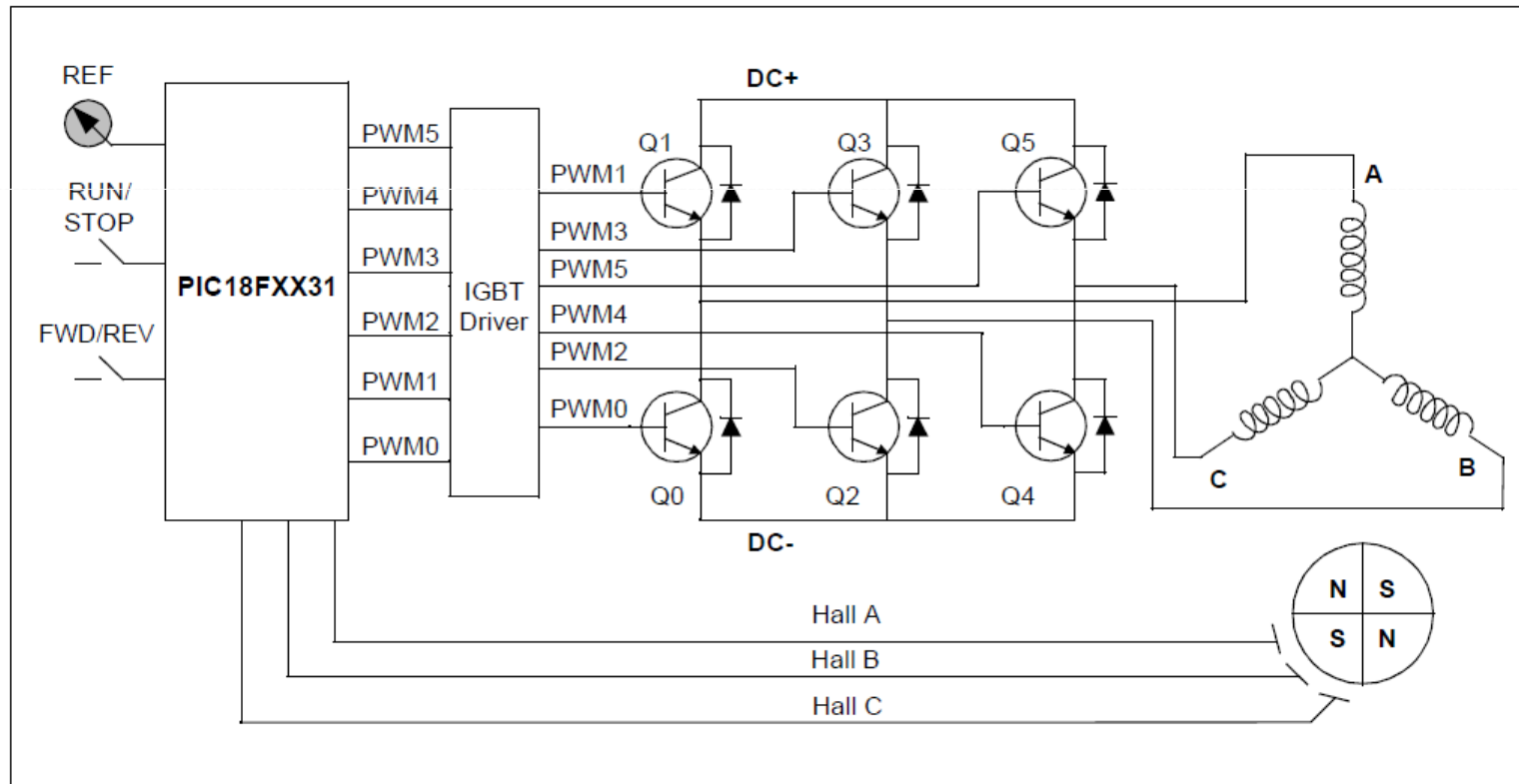

*Note: drawing from Microchip AN885*

# Some general classes of power electronics circuits

- Families of solid state power converters categorized according to their conversion function

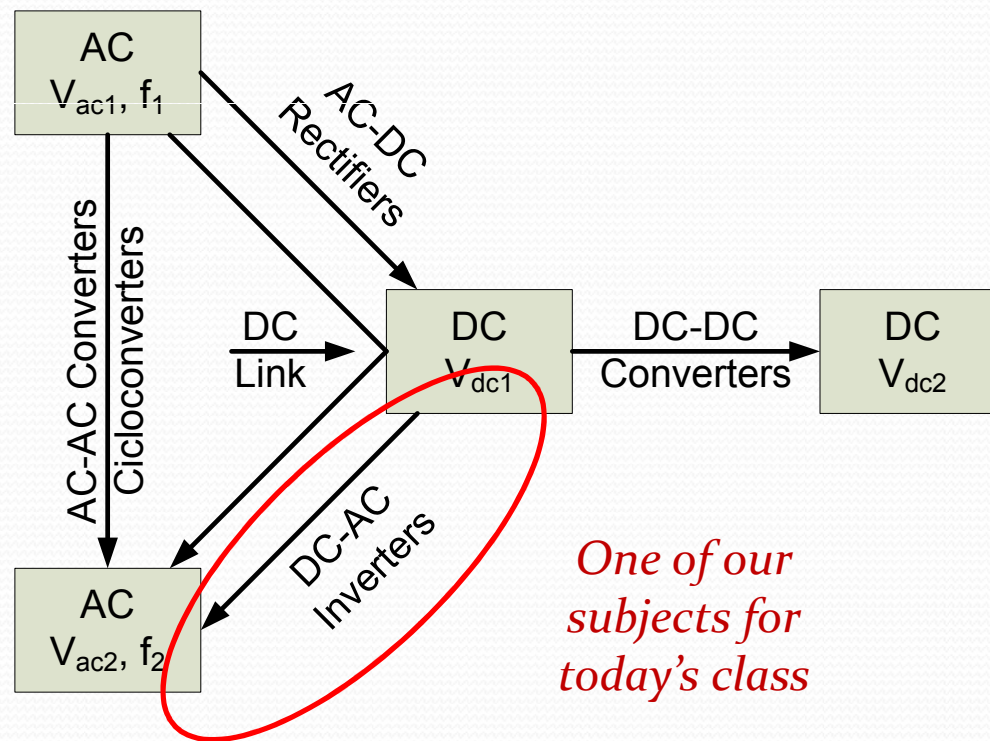

# PWM – Pulse Width Modulation

- The idea is to modulate the width of a stream of pulses, keeping the carrier frequency constant, such that the low pass frequency spectrum produces the required waveform

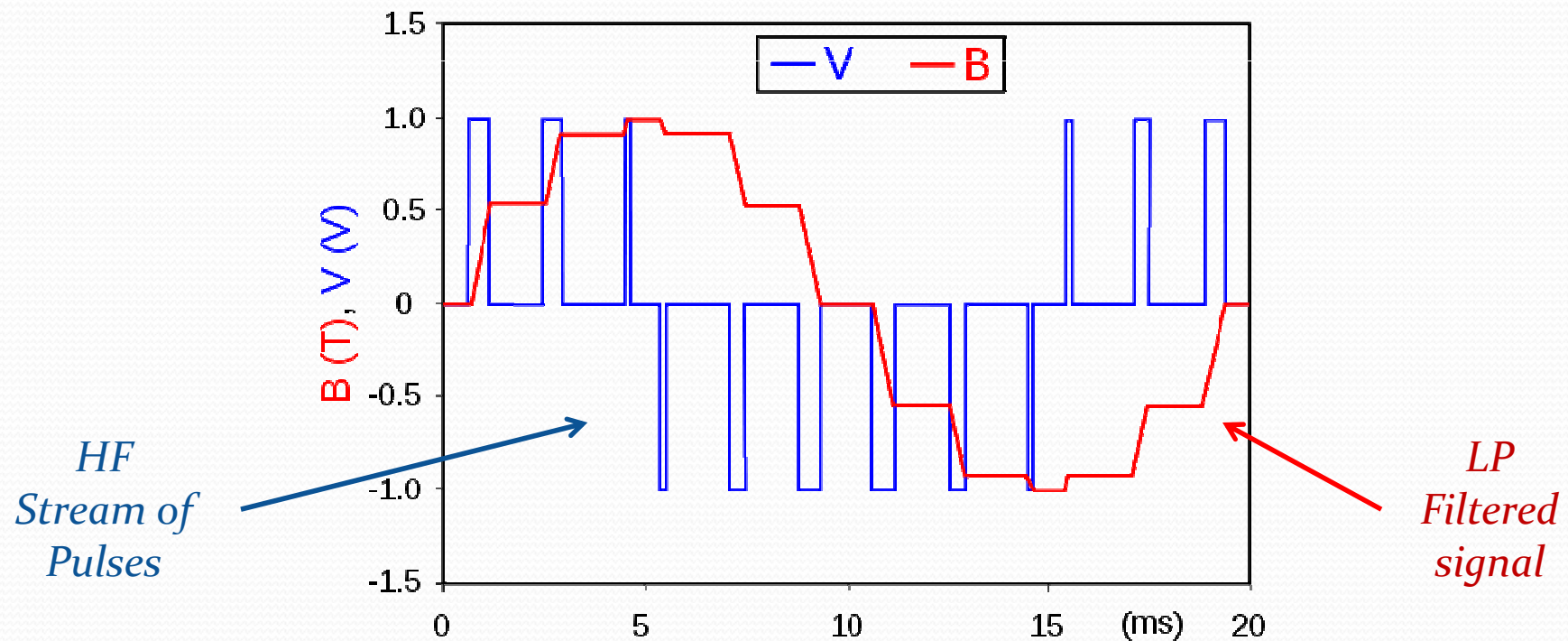

# Introduction to 3-phase inverters

- 6 Transistors Power Converter

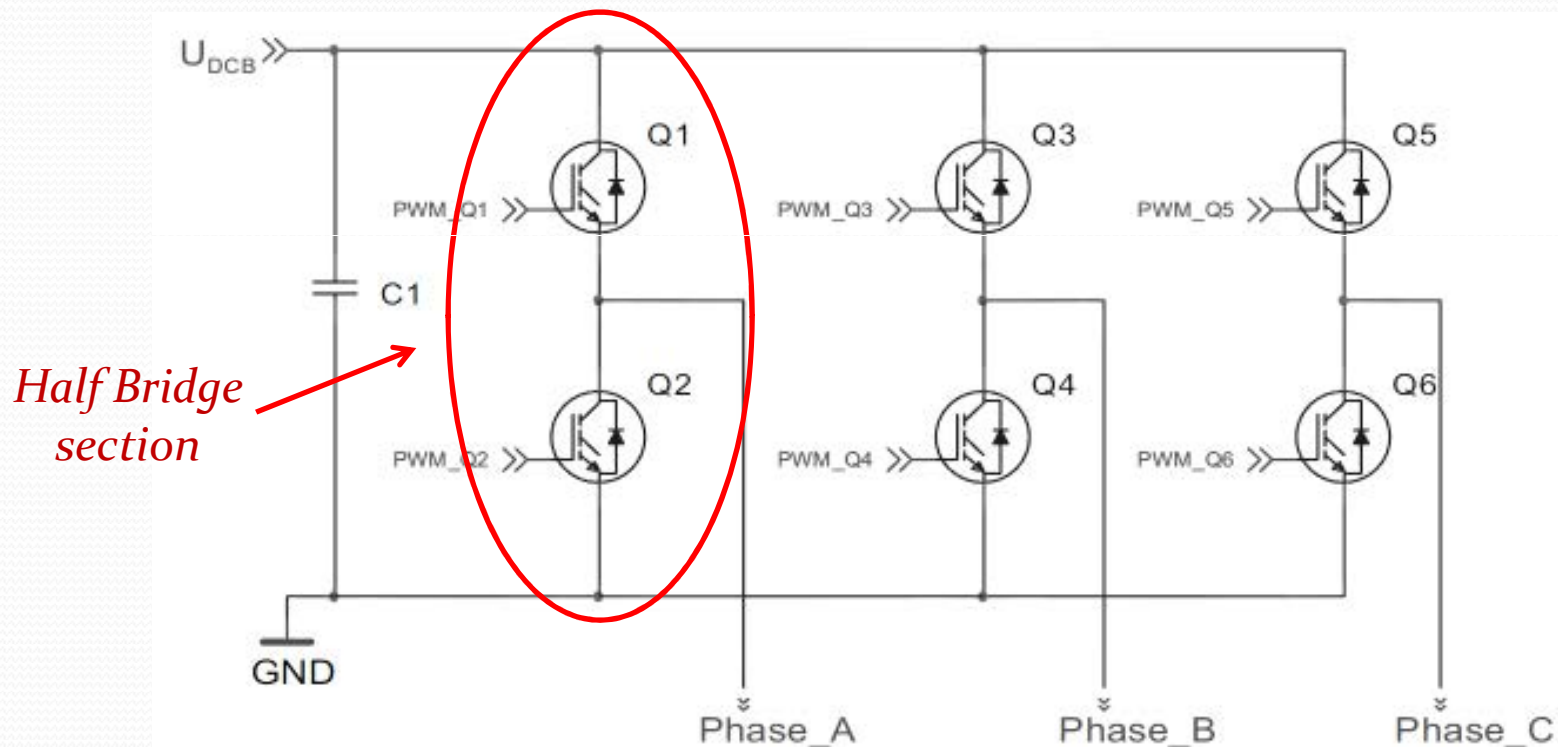

Figure 2-3. 3-Phase BLDC Power Stage

Note: drawing from Freescale AN1916

# Fundamentals of Brushless DC motors

- BLDC Motor Cross Section

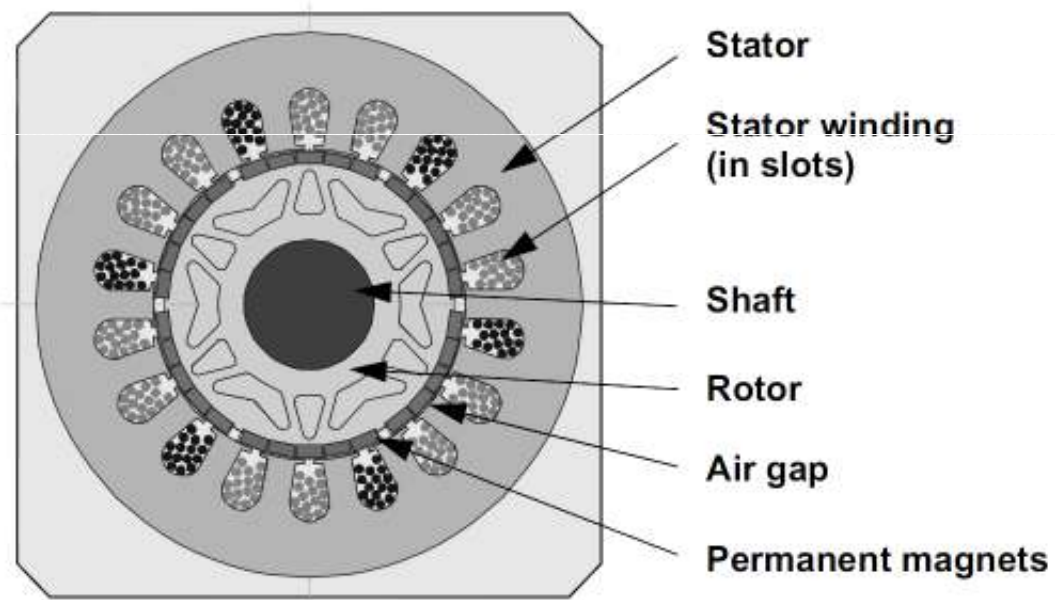
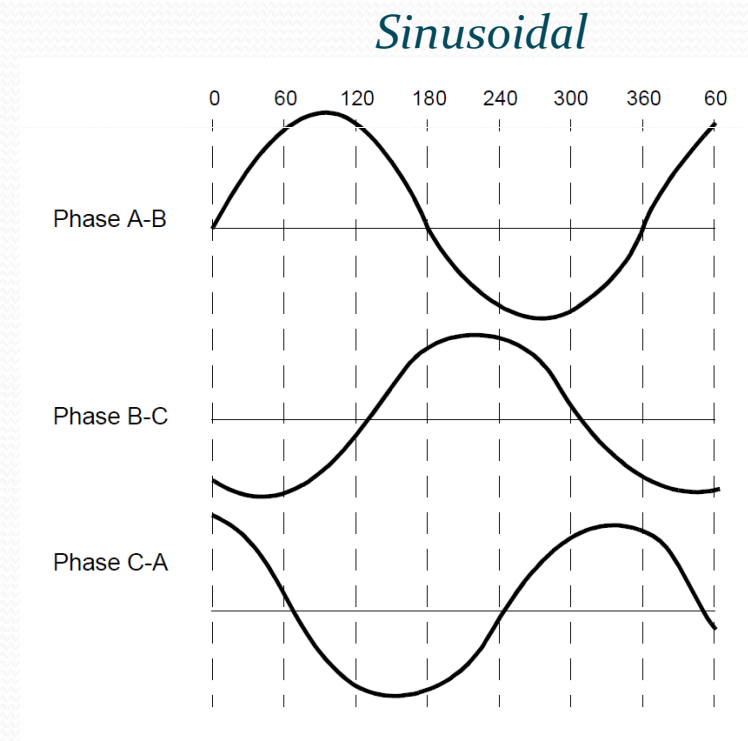
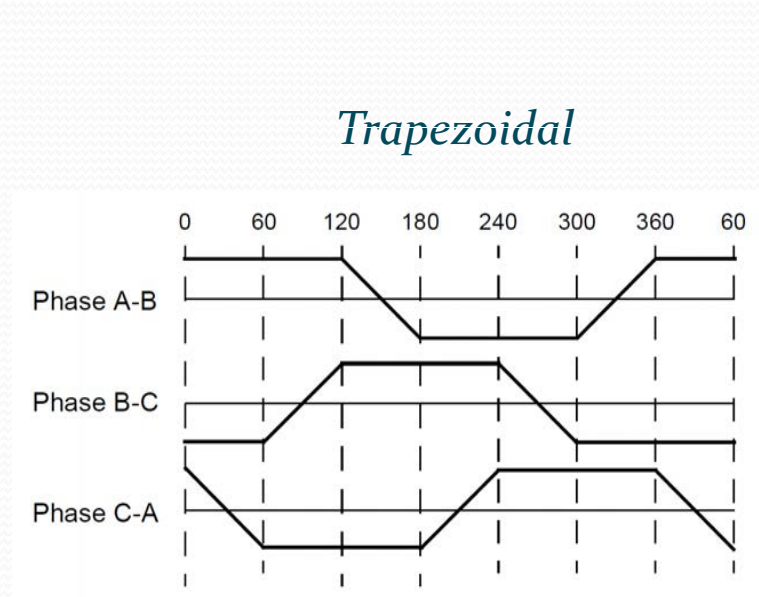

Figure 2-1. BLDC Motor - Cross Section

*Note: drawing from Freescale AN1916*

# Fundamentals of Brushless DC motors

- Types of Back Electro Magnetic Force (BEMF)
  - Depends on BLDCM physical construction



*Note: drawing from Microchip AN885*

# Fundamentals of Brushless DC motors

- Internal View of the Stator and Rotor of a BLDC Motor

*Stator*

AN885

FIGURE 3: STATOR OF A BLDC MOTOR



*Rotor*

FIGURE 4: ROTOR MAGNET CROSS SECTIONS

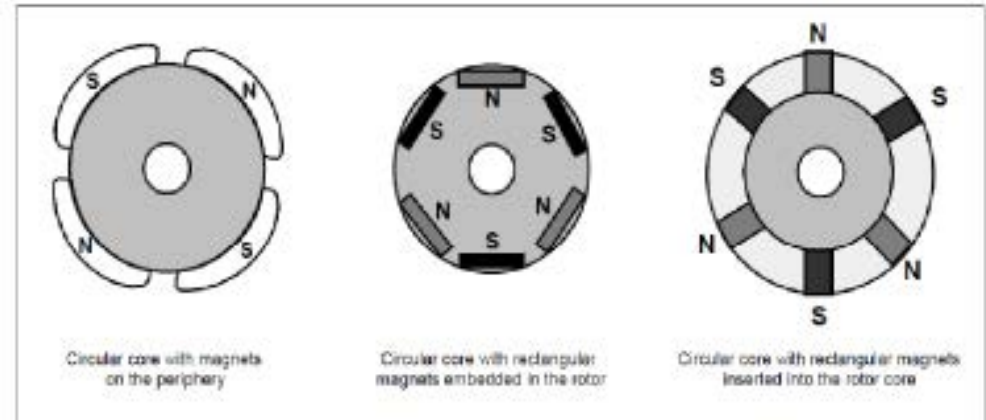

*Note: drawing from Microchip AN885*

# Fundamentals of Brushless DC motors

- Three-Phase Hall Sensors

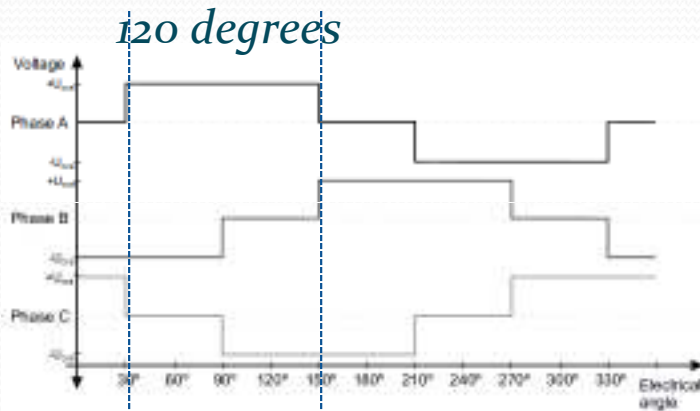
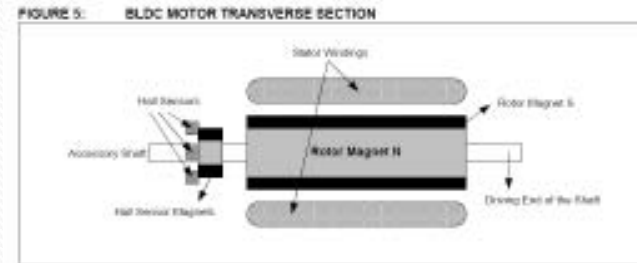
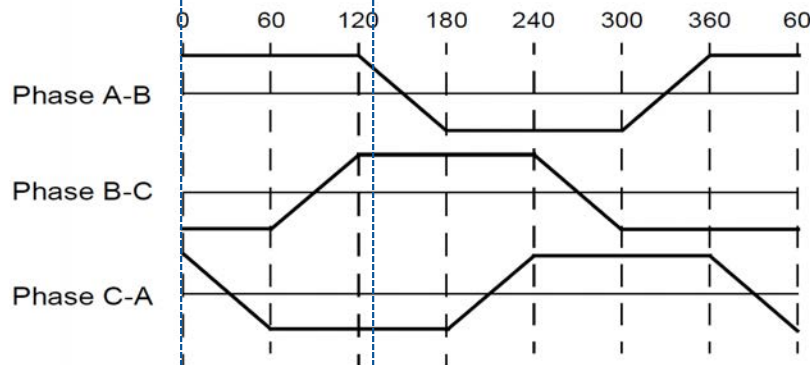

Table 2-1. Commutation Sequence for Clockwise Rotation

Hall Sensor A	Hall Sensor B	Hall Sensor C	Phase A	Phase B	Phase C
1	0	0	-V <sub>DCB</sub>	+V <sub>DCB</sub>	NC
1	0	1	NC	+V <sub>DCB</sub>	-V <sub>DCB</sub>
0	0	1	+V <sub>DCB</sub>	NC	-V <sub>DCB</sub>
0	1	1	+V <sub>DCB</sub>	-V <sub>DCB</sub>	NC
0	1	0	NC	-V <sub>DCB</sub>	+V <sub>DCB</sub>
1	1	0	-V <sub>DCB</sub>	NC	+V <sub>DCB</sub>

Table 2-2. Commutation Sequence for Counterclockwise Rotation

Hall Sensor A	Hall Sensor B	Hall Sensor C	Phase A	Phase B	Phase C
1	0	0	+V <sub>DCB</sub>	-V <sub>DCB</sub>	NC
1	1	0	+V <sub>DCB</sub>	NC	-V <sub>DCB</sub>
0	1	0	NC	+V <sub>DCB</sub>	-V <sub>DCB</sub>
0	1	1	-V <sub>DCB</sub>	+V <sub>DCB</sub>	NC
0	0	1	-V <sub>DCB</sub>	NC	+V <sub>DCB</sub>
1	0	1	NC	-V <sub>DCB</sub>	+V <sub>DCB</sub>



*Note: drawing from Microchip AN885*

# Fundamentals of Brushless DC motors

- Winding Energizing Sequence
  - Dependent on hall sensor encoding

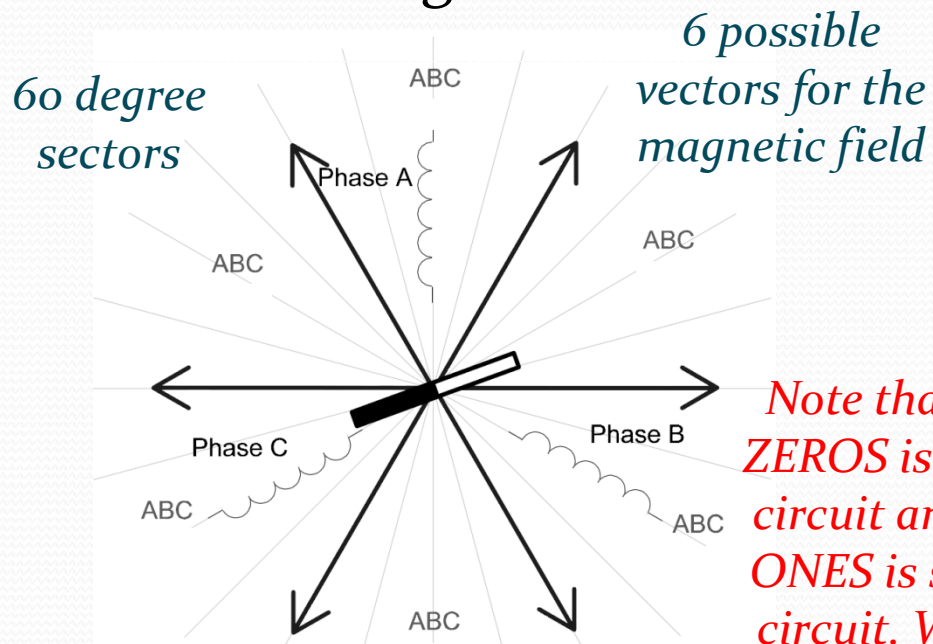

Note that all ZEROS is open circuit and all ONES is short circuit. Why?

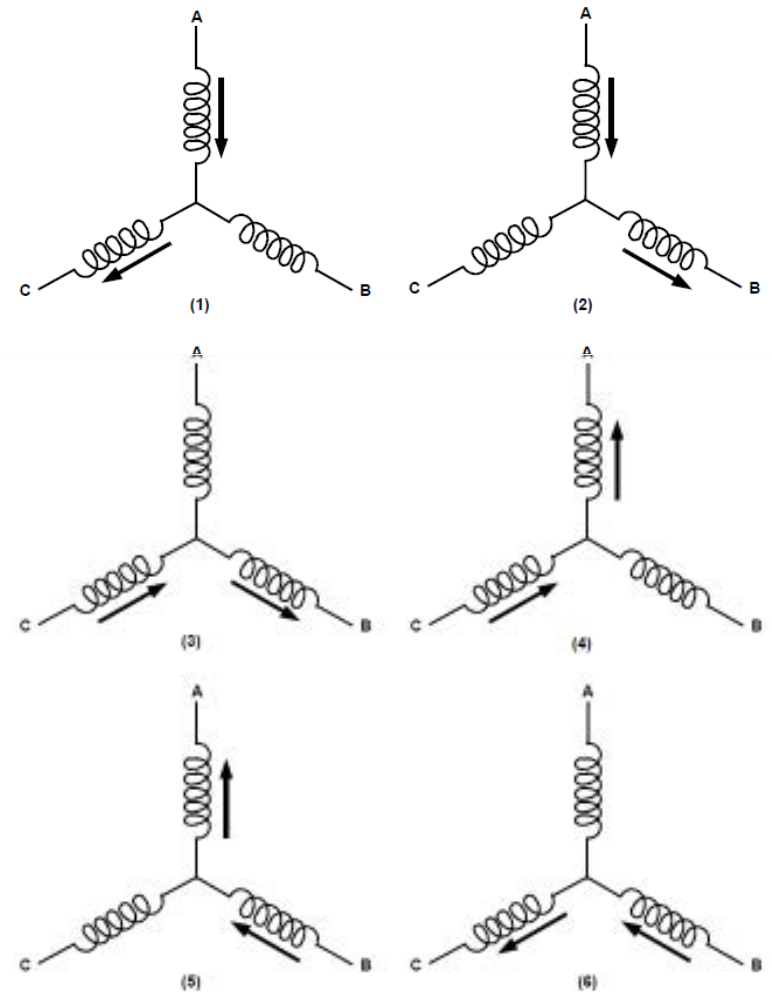

# BLDCM Theory of Operation

- six-steps control algorithm
  - Control logic is not complicated to implement
  - Capable of very high speed operation
  - Relatively high torque ripple compared to other methods (Sinusoidal BEMF, Sinusoidal PWM, FOC, SVM, etc.)
  - High current ripple implies high harmonic content and higher operating temperature (for the same operating conditions)

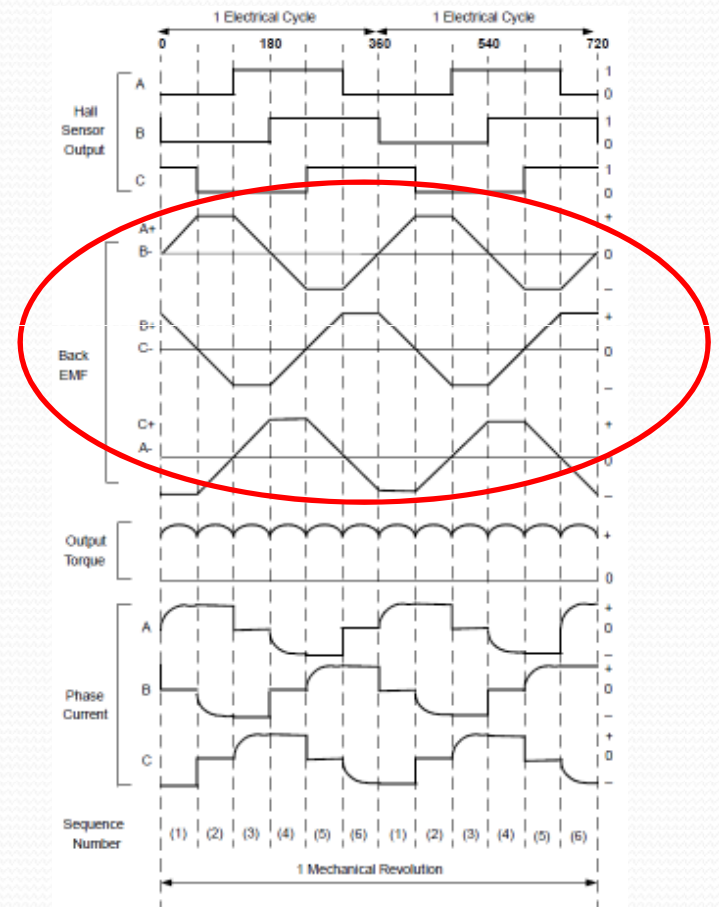

*Note: drawing from Microchip AN885*

# Speed control of BLDC motors

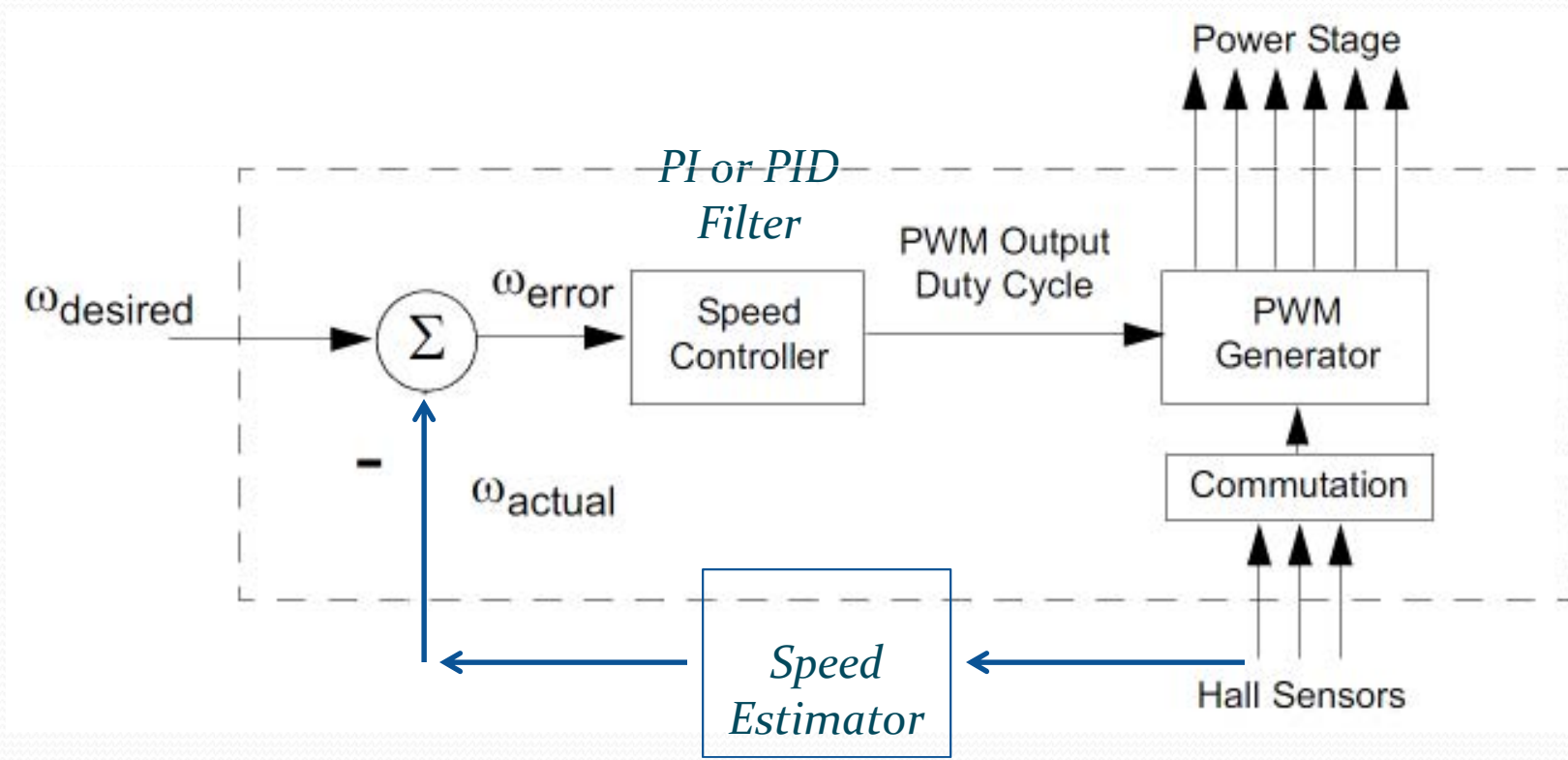

Note: drawing from Freescale AN1916

# Torque control of BLDC motors

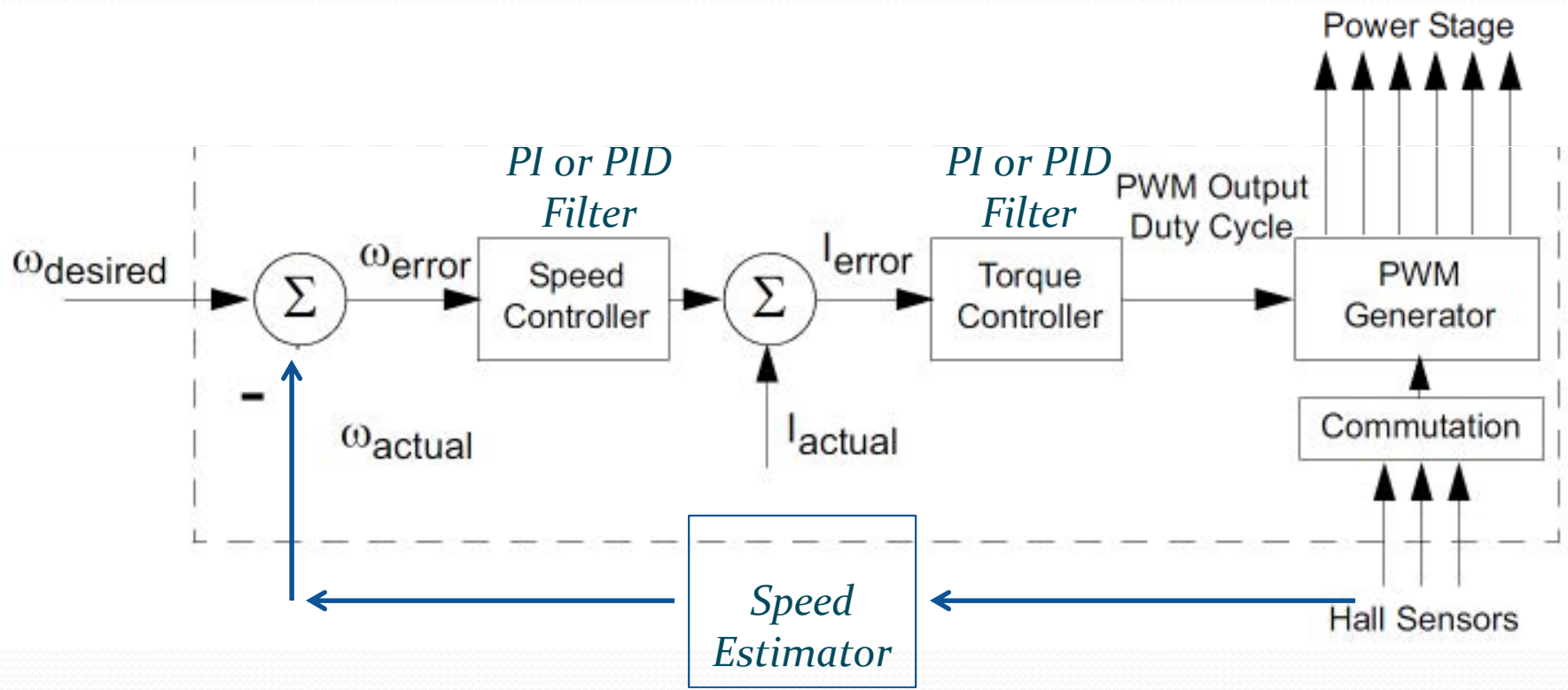

Note: drawing from Freescale AN1916

# Putting it all together

- Control Block Diagram

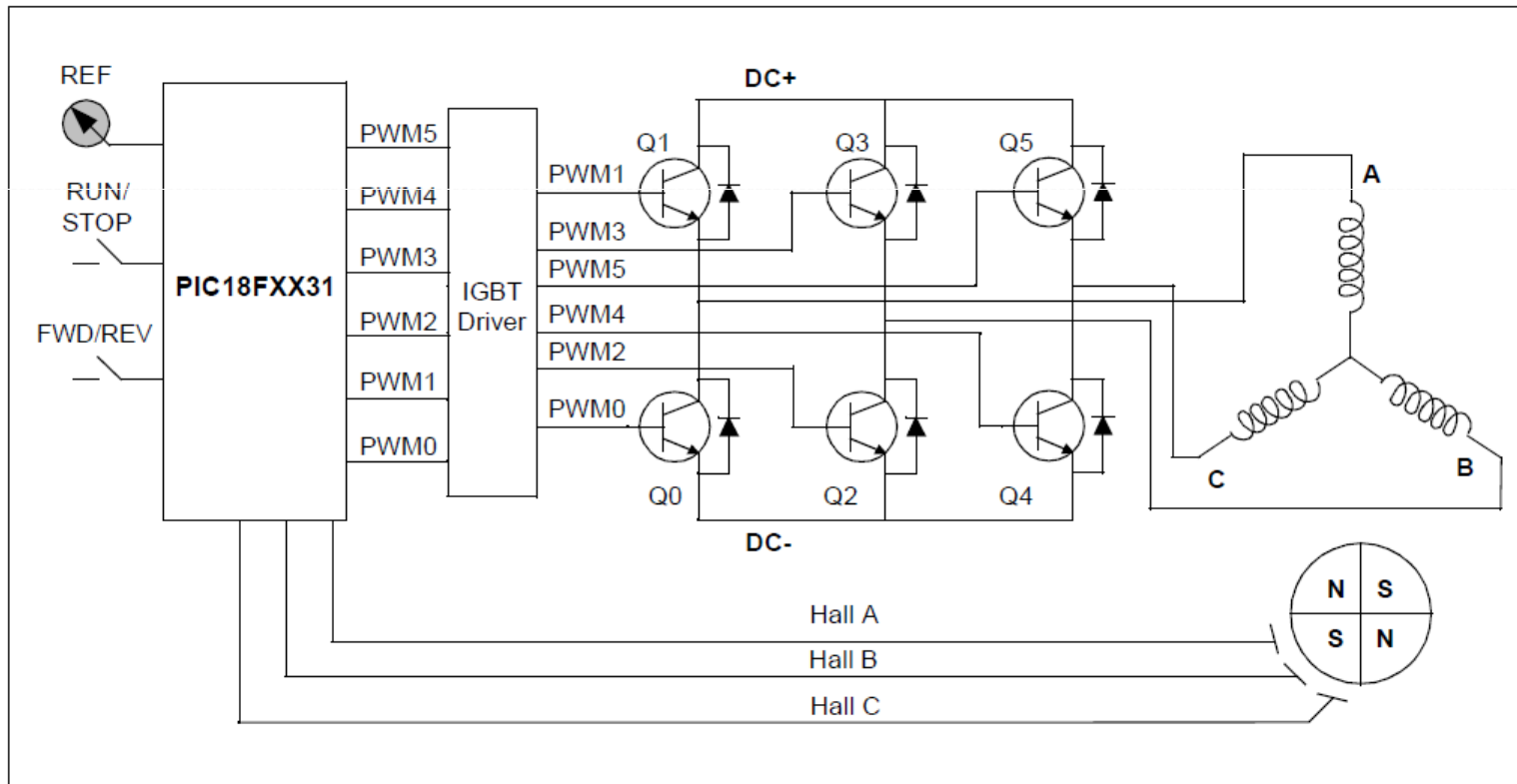

*Note: drawing from Microchip AN885*



# Putting it all together



# For further study

- Two others interesting examples on power electronics



# Example #3

## Forced switching

- phase controlled rectifier

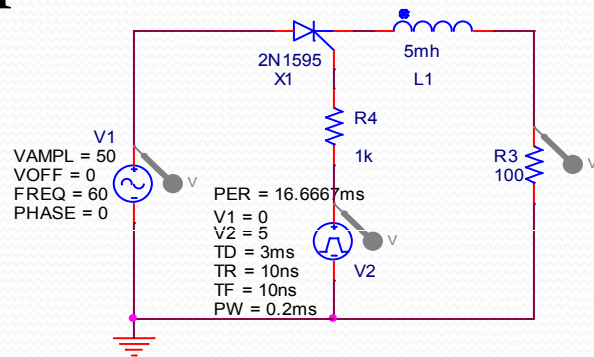

## DC-DC Converter

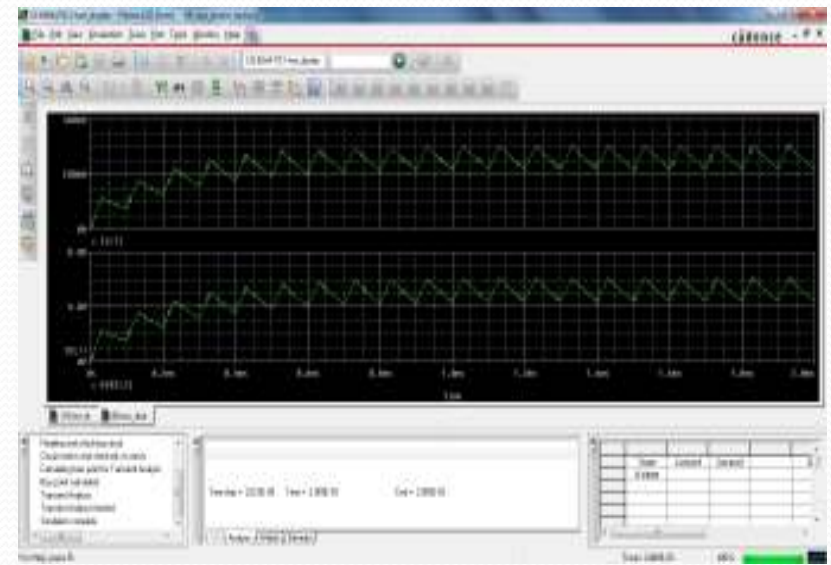
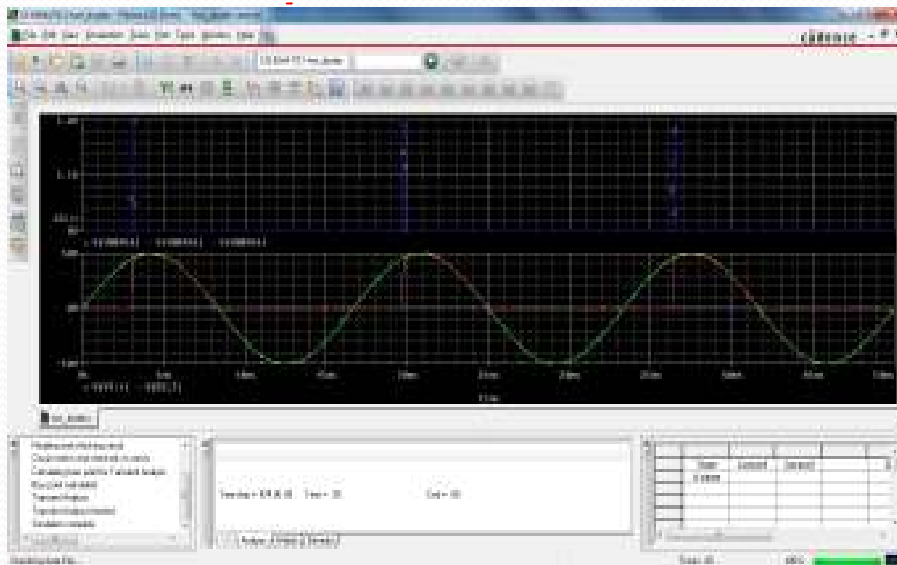
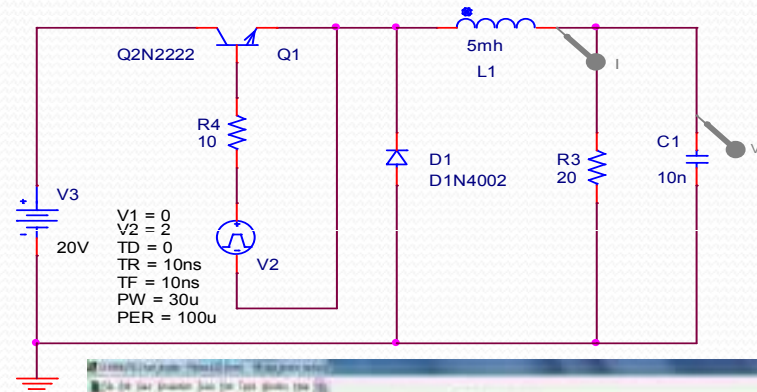

# Conclusion

## Resources available

- Orcad version 16.3 Student Edition – Free
  - <http://www.cadence.com/products/orcad/pages/downloads.aspx>
  - NOTE: The student edition has limitations in terms of # of components, # of pins, etc.
- We will publish a copy of the example circuits
- The internet has many useful links
  - Search for “pspice and power and electronics”



# References on Power Electronics

- This is one of the best references
  - Erickson, R. W. & Maksimovic, D., “Fundamentals of Power Electronics,” 2<sup>nd</sup> Edition, University of Colorado, Boulder, <http://ecee.colorado.edu/copec/book/slides/slidedir.html>
- These are good references as well
  - Ramshaw, E. & Shuumman, D. C., “PSpice Simulation of Power Electronics Circuits: An Introductory Guide,” Springer Verlag, 1996
  - Ferrieux, J. P. & Forest, F., “Alimentation à découpage - Convertisseurs à résonance: principes, modélisation, composants,” Collection technologies, Masson, Paris, 1987, ISBN 2-225-81205-5
  - Tolyat, H. A. & Campbell, S., “DSP-Based Electromechanical Motion Control,” CRC Press, 2003



## References on Control of BLDCM

- 1) *Leonard N. Elevation*, “3-Phase BLDC Motor Control with Hall Sensors Using 56800/E Digital Signal Controllers,” *Freescale Semiconductor, AN1916, Rev. 2.0, 11/2005*
- 2) *Padmaraja Yedamale*, “Brushless DC (BLDC) Motor Fundamentals,” *Microchip Technology Inc., AN885, 2003*



# Q & A

- Thank you
- My contact:
  - Julio Pimentel
  - [jpiment@kylowave.com](mailto:jpiment@kylowave.com)