



ITI 1220 / 1620 Fall 2005 Introduction to Computing I Midterm Examination

Length of Examination: 1.5 hours

October 22, 2005, 10:00

Professors: Daniel Amyot, Alan Williams

Page 1 of 10

Instructions: Please read carefully!

- 1. Complete all sections of the identification area in ink.**
- 2. This is a closed-book test. No books, papers, calculators or other electronic devices are permitted.**
- 3. Answer all questions on the question sheet in the area provided. Questions answered in pencil will not be re-graded even if there is a marking error.**
4. The marks allocated to each question are indicated. Not all questions are worth the same amount, so plan your time accordingly. The midterm will be scored out of 40 marks, which represents 20% of your final grade.
5. Algorithms are to be described using the format from the lectures and the notes.
6. You can use the back of the question sheet pages, or page 9, for calculations and other work. Pages 9 and 10 can be detached as they will not be marked.
7. Les réponses en français sont acceptées.

Identification:

For use of grader:

Name: _____

ID number: _____

Lecture Section (circle one):

A (Mon/Thurs)

B (Tues/Fri)

Question	Marks available	Marks received
1	8	
2	10	
3	10	
4	12	
Total	40	

Question 1 (8 marks total – 4 marks for each part)**Part a)**

The integer X has the value 5, and the array Y initially contains the following values: {2, 4, 6, 8, 10}. Only **one** of the following Boolean expressions evaluates to true.

Circle the letter corresponding to the expression that evaluates to true.

- a) $(X < 5) \text{ OR } (Y[Y[1]] = 8)$
- b) $(Y[4] \div 2 = X) \text{ AND } (X \text{ MOD } 2 = Y[1] \text{ MOD } 2)$
- c) $(X > Y[2]) \text{ AND } (X \leq Y[3])$
- d) $Y[Y[0]] \times 2 = (2 \times X + X \text{ MOD } 3)$
- e) $X \times X \leq Y[1] \times Y[2]$

Part b)

What would be the values of D and E after the following algorithm executes, if A has the value { 6, 15, 8, 20, 14, 10 } and B has the value 6?

GIVENS: A, B

RESULTS: D, E

HEADER (D,E) \leftarrow AnAlgorithm(A, B)

INTERMEDIATE: C

BODY:

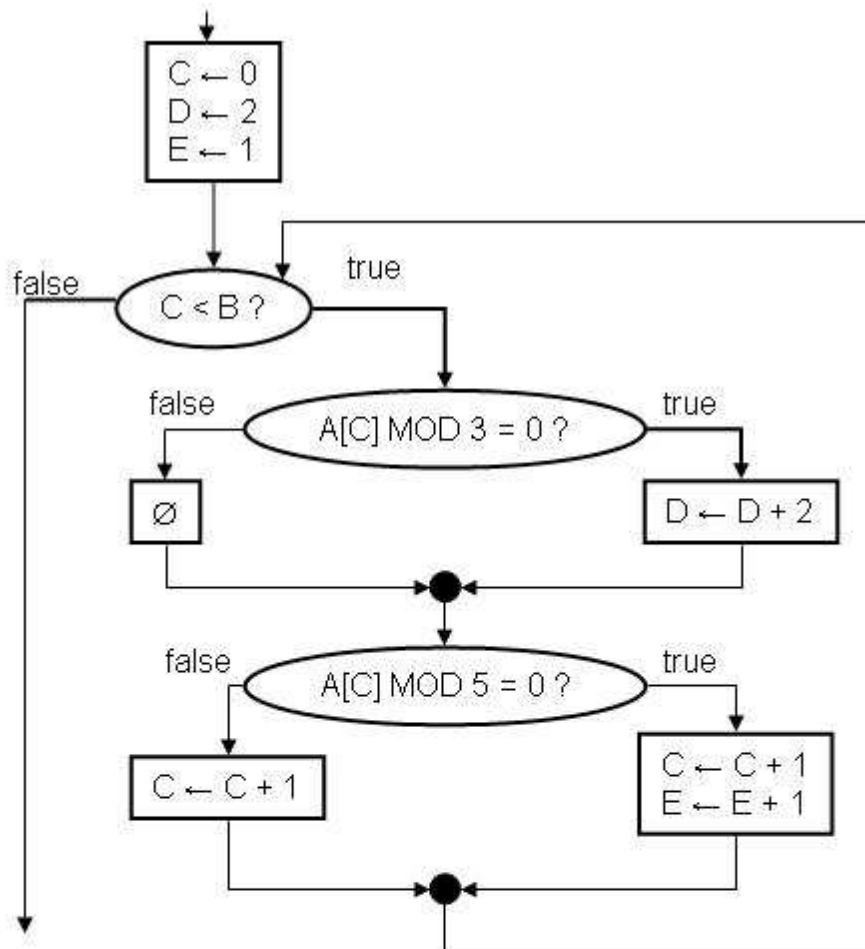

Answer: D = _____

E = _____

Question 2 (10 marks in total – 5 marks for each part)**Part a)**

The following program attempts to extract a sub-array from an array input by the user. That new `subArray` contains only the elements of the input array that have odd indices (`anArray[1]`, `anArray[3]`...). However, two errors were made when producing this program. One error is a syntax error, while the other error is a logic error in the algorithm.

```
class Q2a
{
    public static void main ( String[] args )
    {
        // DECLARE VARIABLES / DATA DICTIONARY
        int[] anArray;           // GIVEN: an array of values
        int anArrayLength;      // GIVEN: number of values in anArray
        int subArrayLength;     // INTERMEDIATE: size of a sub-array
        int index;              // INTERMEDIATE: position in an array
        int[] subArray;         // RESULT: new sub-array

        // READ IN GIVENS
        System.out.print( "Enter an array of integers: " );
        anArray = ITI1220.readIntLine( );
        anArrayLength = anArray.length;

        // ALGORITHM BODY

        subArrayLength = anArrayLength / 2;
        subArray = int[subArrayLength];           // create array
        index = 0;                                // first odd index

        while (index < anArrayLength)
        {
            subArray[index] = anArray[index*2+1];
            index = index + 2;                    // next odd index
        }

        // PRINT RESULTS AND MODIFIEDS

        index = 0;
        while (index < subArrayLength)
        {
            System.out.print(subArray[index] + " ");
            index = index + 1;
        }
    }
}
```

Describe the errors here:

Part b)

What would be printed by the following program? Circle the letter next to the correct answer.

```
int [] x;
int r;
int i;

x = new int[] {2, 3, 4, 5, 6};
r = 1;
i = x.length-1;

while ( i > 0 )
{
    r = r * x[i];
    if (r > 100)
    {
        i = i -1;
    }
    else
    {
        ; // do nothing
    }
    i = i -1;
}

System.out.println( r );
```

- a) 720
- b) 360
- c) 144
- d) 120
- e) 60
- f) There is a run-time execution error.

Question 3 (10 marks)

Translate the algorithm found in appendix A on page 10 to a Java program by completing the partially filled `main()` method below and on the next page. You do not need to add an identification section to the program.

```
public static void main( String[] args )
{
    // DECLARE VARIABLES / DATA DICTIONARY

    // READ IN GIVENS (no modification needed here)

    System.out.println( "Enter an array of integers: " );

    a = ITI1220.readIntLine( ); // reads entire array
    n = a.length; // find length of array

    // ALGORITHM BODY: next page
```

```
// ALGORITHM BODY
```

```
// PRINT OUT RESULTS AND MODIFIEDS  
System.out.println( "The result is: " + duplicates );  
}
```

Question 4 (12 marks)

Suppose that you have an array **BoltSizes** containing the measured lengths, in millimetres, of various bolts after they have been manufactured. There are **N** values in this array. The bolts are intended to have the measured length **CorrectSize**, but the size is permitted to vary, plus or minus, up to and including the amount **Tolerance** to be acceptable.

Design an algorithm to count the number of bolts that should be rejected.

For example, if the bolt sizes are 50.03, 50.02, 49.97, 50.04, 50.01, 50.00, and 49.99, the correct size is 50.0, and the tolerance is 0.02, the algorithm would return 3.

This page is for calculations and other work (you can detach this page; it will not be marked)

Appendix A: Algorithm for Question 3 (you can detach this page)

GIVENS: A (An array of integers)
 N (Number of values in the array A)

RESULT: Duplicates (Boolean: True if A contains duplicate values)

HEADER: Duplicates \leftarrow HasDuplicates(A, N)

INTERMEDIATES: CheckIndex (Index of left comparison value)
 DupIndex (Index of right comparison value)

BODY:

