

Digital Systems

Based on Principles and Applications of Electrical Engineering/Rizzoni (McGraw Hill)

- **Objectives:**
- Analyze the operation of sequential logic circuits.
- Understand the operation of digital counters.
- Design simple sequential circuits using state transition diagrams.
- Study the basic architecture of microprocessors and microcontrollers.
- Introduce the basics of mechatronics.

Sequential logic differs from combinational logic in that the output of the logic device is dependent not only on the present inputs to the device, but also on past inputs; i.e., the output of a sequential logic device depends on its present internal state and the present inputs. This implies that a sequential logic device has some kind of memory of at least part of its “history” (i.e., its previous inputs).

See to the right

RS flip-flop symbol and truth table

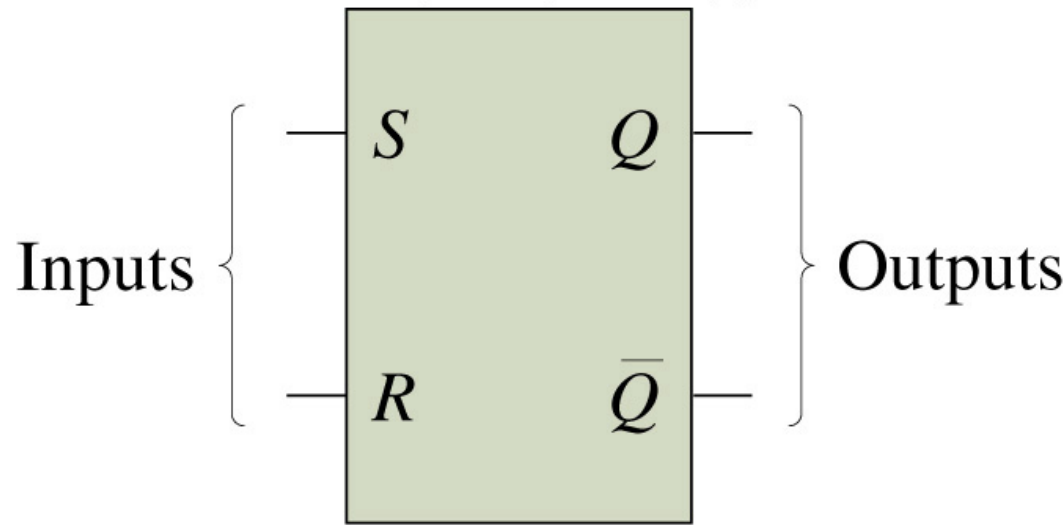

S	R	Q
0	0	Present state
0	1	Reset
1	0	Set
1	1	Disallowed

Timing diagram for the *RS* flip-flop

Copyright © The McGraw-Hill Companies, Inc. Permission required for reproduction or display.

<i>S</i>	<i>R</i>	<i>Q</i>
1	0	1
0	0	1
0	0	1
0	1	0
0	0	0
0	0	0
0	1	0
0	0	0
1	0	1
0	0	1

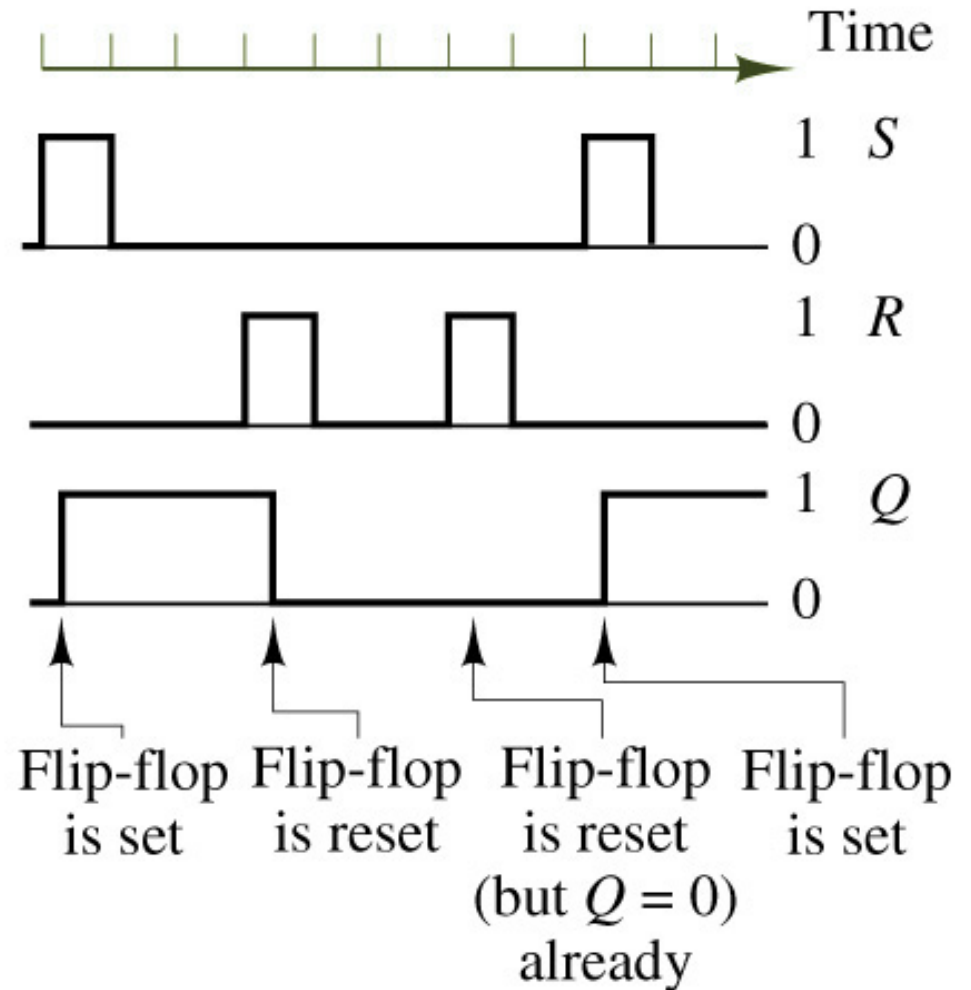

The *RS* flip-flop with enable, preset, and clear lines: (a) logic diagram, (b) timing diagram, (c) IC schematic

Copyright © The McGraw-Hill Companies, Inc. Permission required for reproduction or display.

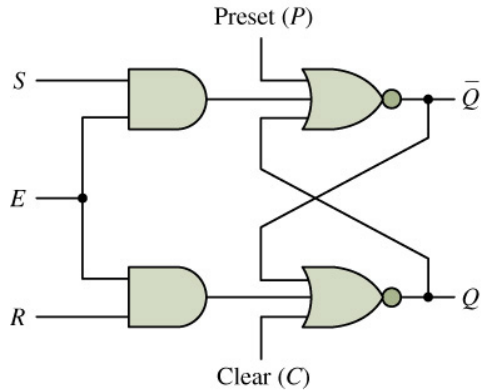

(a)

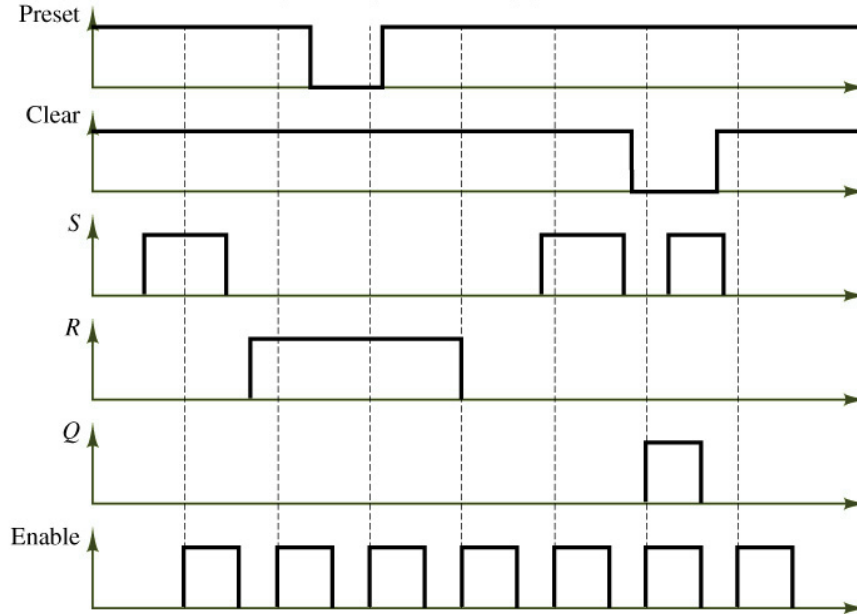

Timing diagram

(b)

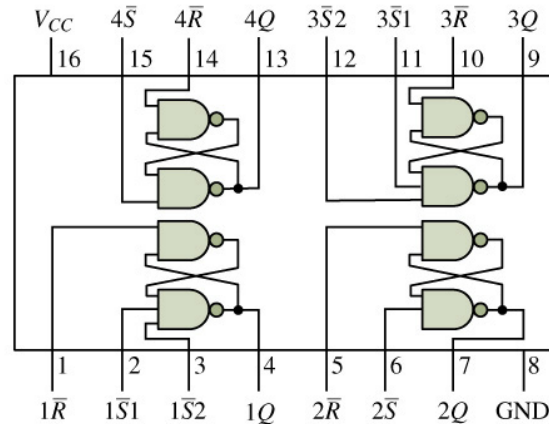

(c)

Data latch and associated timing diagram

Copyright © The McGraw-Hill Companies, Inc. Permission required for reproduction or display.

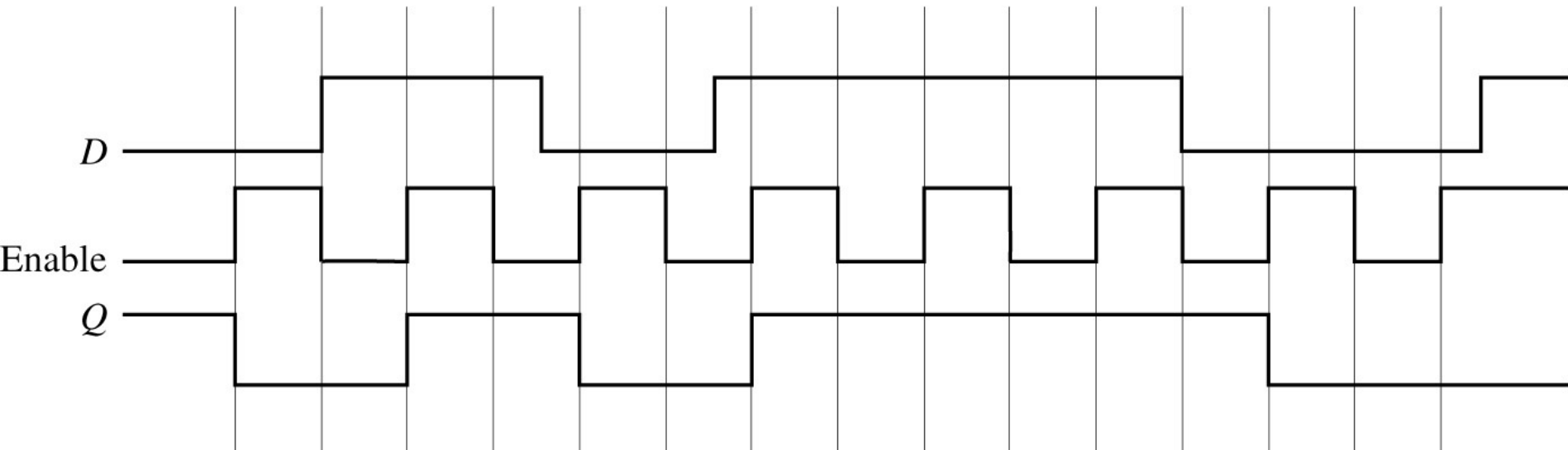
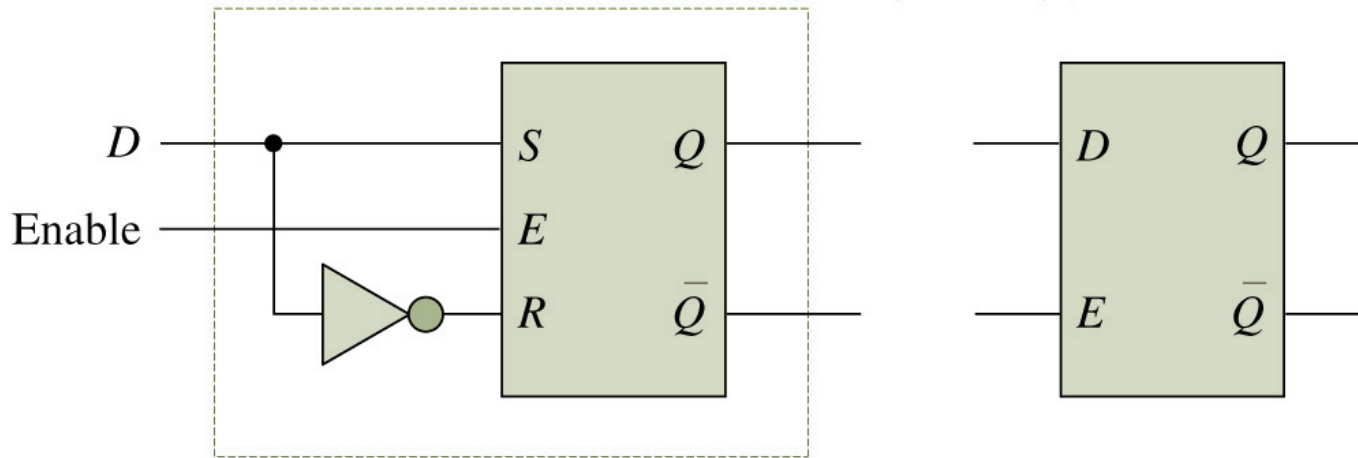

The *D* flip-flop: (a) functional diagram, (b) symbol, (c) timing waveforms, and (d) IC schematic

Copyright © The McGraw-Hill Companies, Inc. Permission required for reproduction or display.

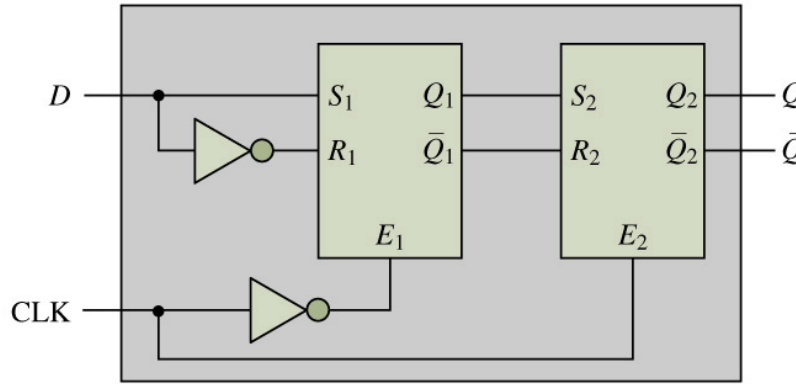

Functional diagram

(a)

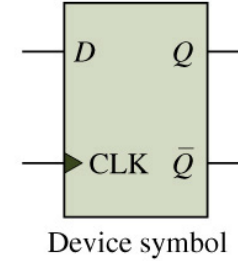

Timing diagram

(b)

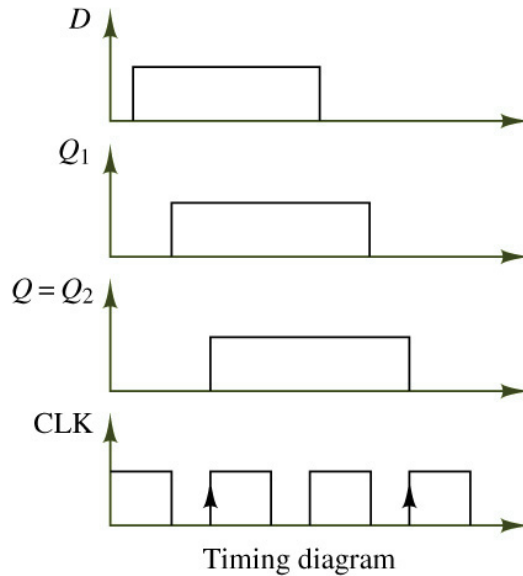

Timing diagram

(c)

Pin assignments for DIP and SOIC

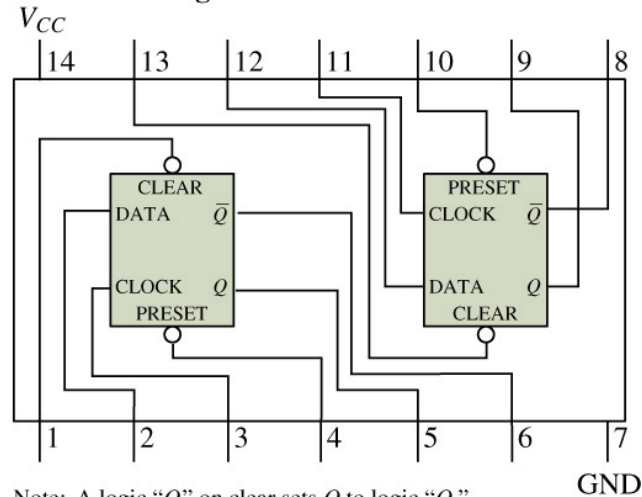

Note: A logic "0" on clear sets *Q* to logic "0."
A logic "0" on preset sets *Q* to logic "1."

Top View

(d)

The JK flip flop is the most versatile flip-flop, and the most commonly used flip flop when discrete devices are used to implement arbitrary state machines. Like the RS flip-flop, it has two data inputs, J and K, and a clock input. It has no undefined states or race condition, however. It is always edge triggered; normally on the falling edge. (some JK flip-flops; e.g., 74109, trigger on the positive edge.)

See to the right:

The JK flip-flop:

(a) functional diagram, (b) device symbol, and (c) IC schematic

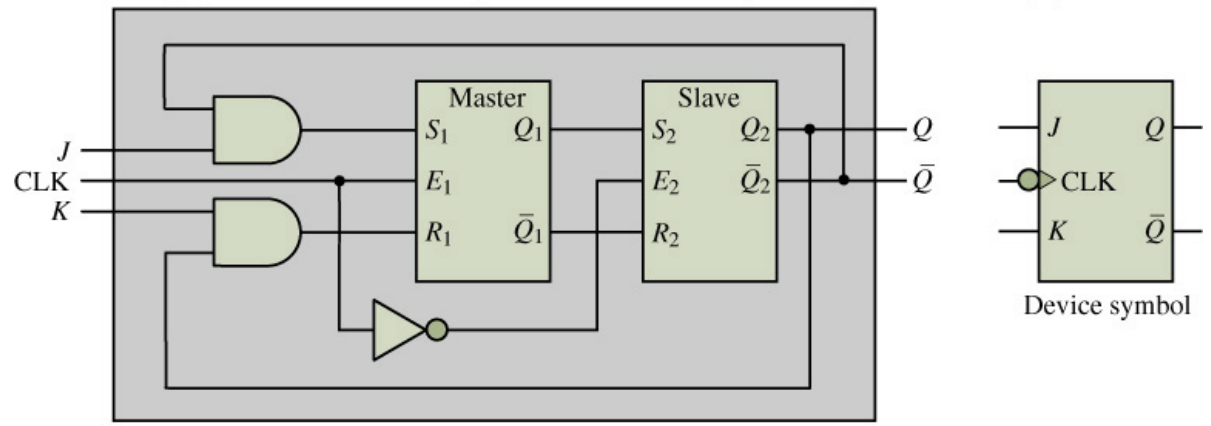

Functional diagram

(a)

Device symbol

(b)

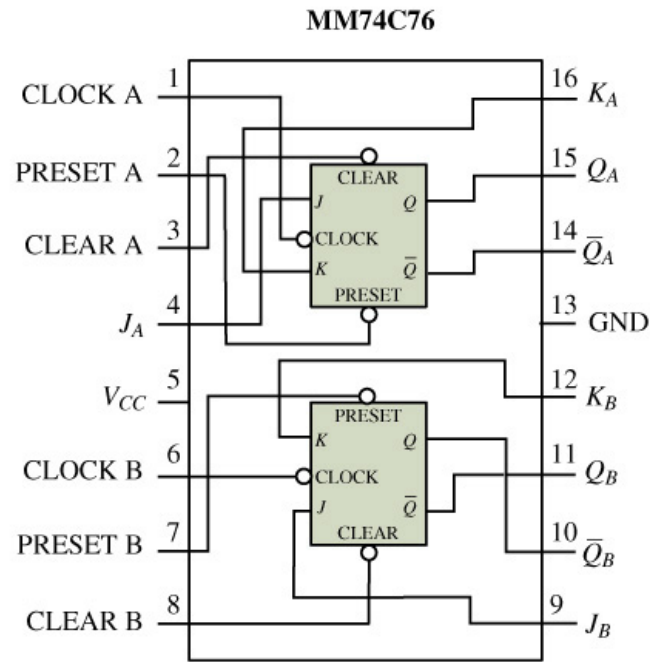

Note: A logic "0" on clear sets Q to logic "0."
A logic "0" on preset sets Q to logic "1."

Top View

(c)

If one input (J or K) is at logic 0, and the other is at logic 1, then the output is set or reset (by J and K respectively), just like the RS flip-flop, but on the (falling) clock edge.

If both inputs are 0, then it remains in the same state as it was before the clock pulse occurred; again like the RS flip-flop.

If both inputs are high, however the flip-flop changes state whenever the (falling) edge of a clock pulse occurs; i.e., the clock pulse toggles the flip-flop.

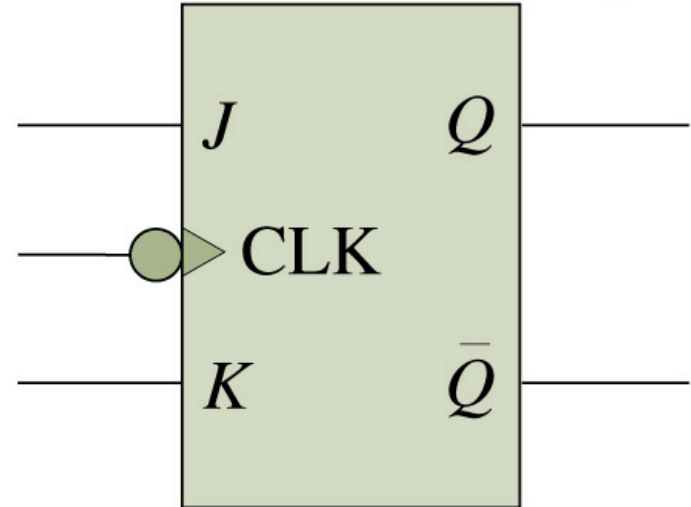

JK flip-flop

See to the right

Truth table for the JK flip-flop

J_n	K_n	Q_{n+1}
0	0	Q_n
0	1	0 (reset)
1	0	1 (set)
1	1	\bar{Q}_n (toggle)

Counters

A common requirement in digital circuits is counting, both forward and backward. Digital clocks and watches are everywhere, timers are found in a range of appliances from microwave ovens to VCRs, and counters for other reasons are found in everything from automobiles to test equipment. The following figure shows a ripple counter.

Copyright © The McGraw-Hill Companies, Inc. Permission required for reproduction or display.

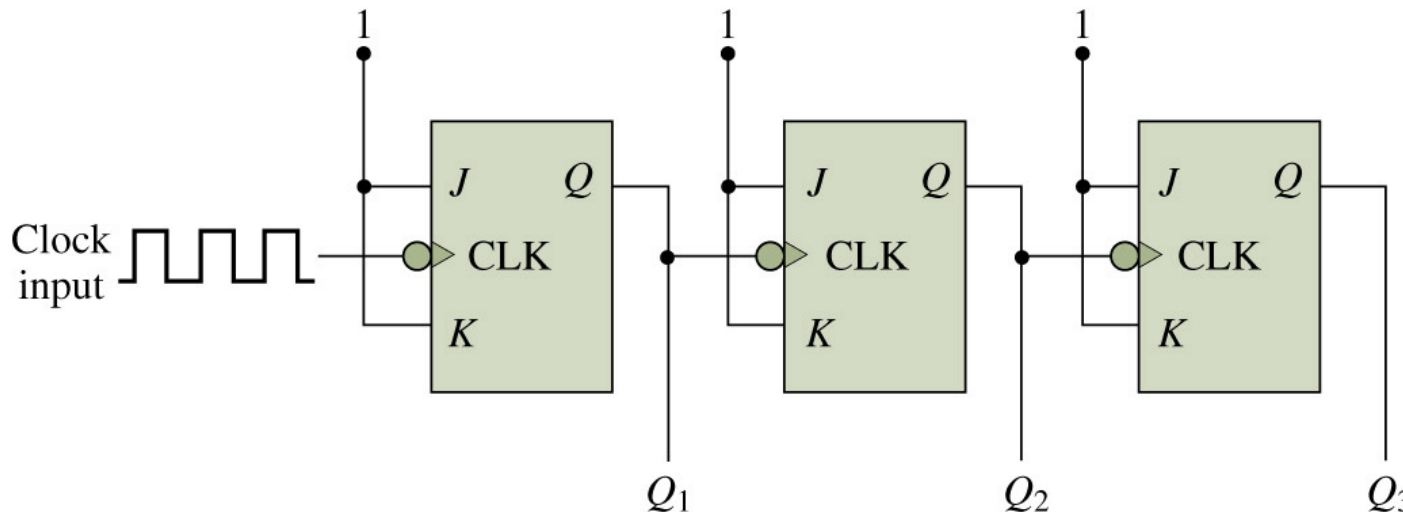

Input	Q_3	Q_2	Q_1
	0	0	0
	0	0	1
	0	1	0
	0	1	1
	1	0	0
	1	0	1
	1	1	0
	1	1	1

Three-Bit Synchronous Counter

The synchronous counter is similar to a ripple counter with two exceptions: The clock pulses are applied to each FF, and additional gates are added to ensure that the flip flops toggle in the proper sequence.

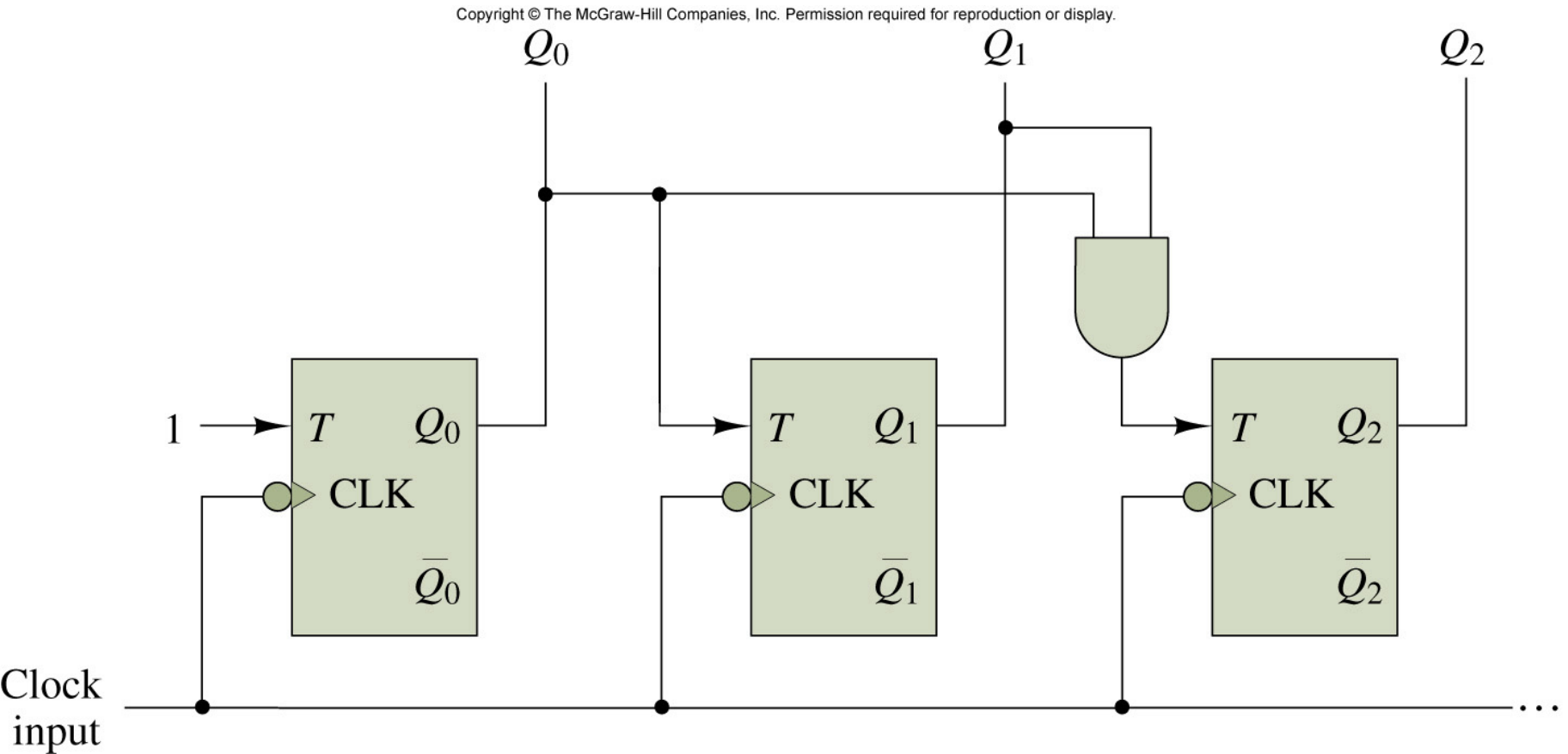

Ring Counter

A ring counter is basically a circulating shift register in which the output of the most significant stage is fed back to the input of the least significant stage. The following is a 4-bit ring counter constructed from D flip-flops. The output of each stage is shifted into the next stage on the positive edge of a clock pulse. If the CLEAR signal is high, all the flip-flops except the first one are reset to 0. The first one is preset to 1 instead.

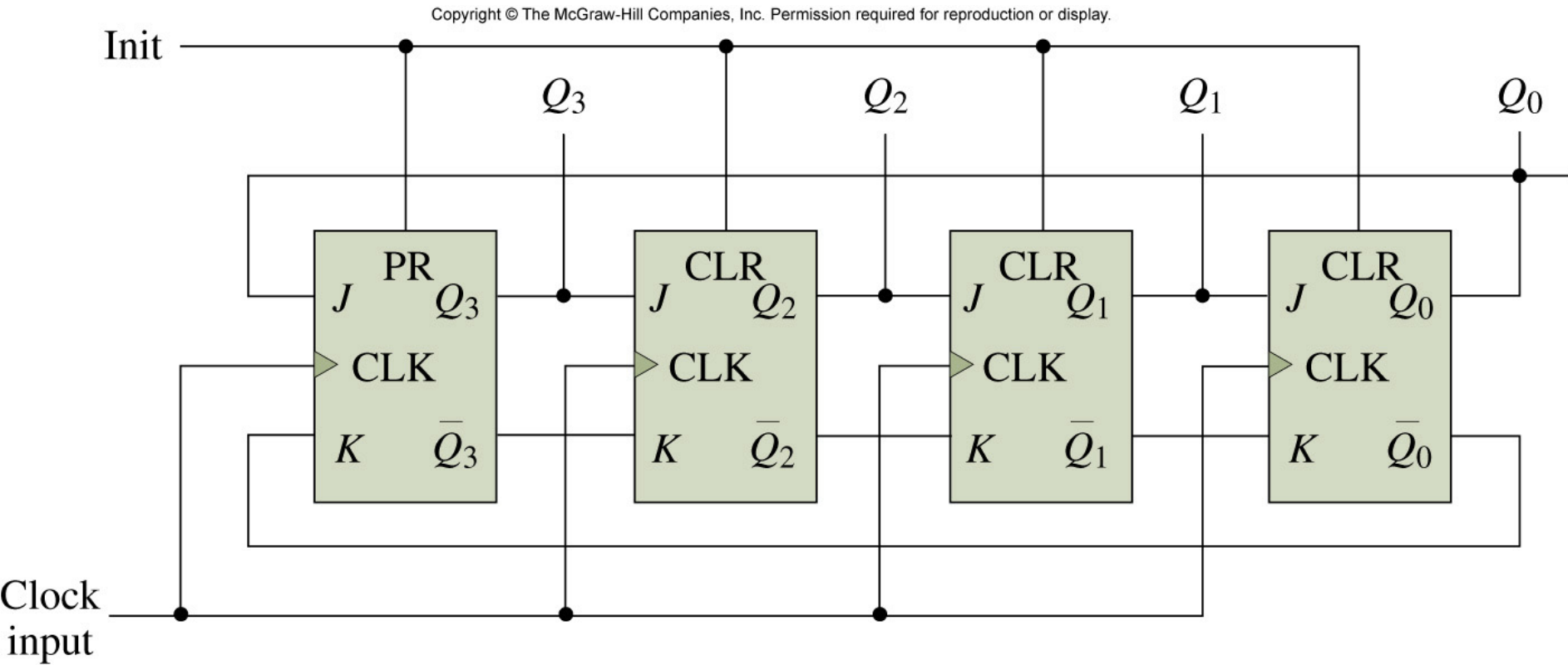

Flip-Flop Applications

Asynchronous (Ripple) Counters

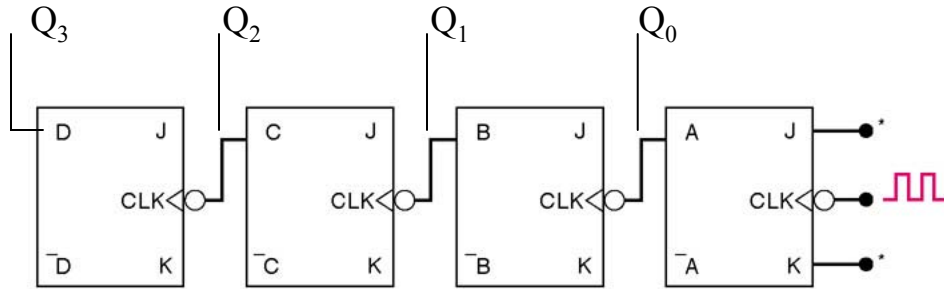

*All J and K inputs assumed to be 1.

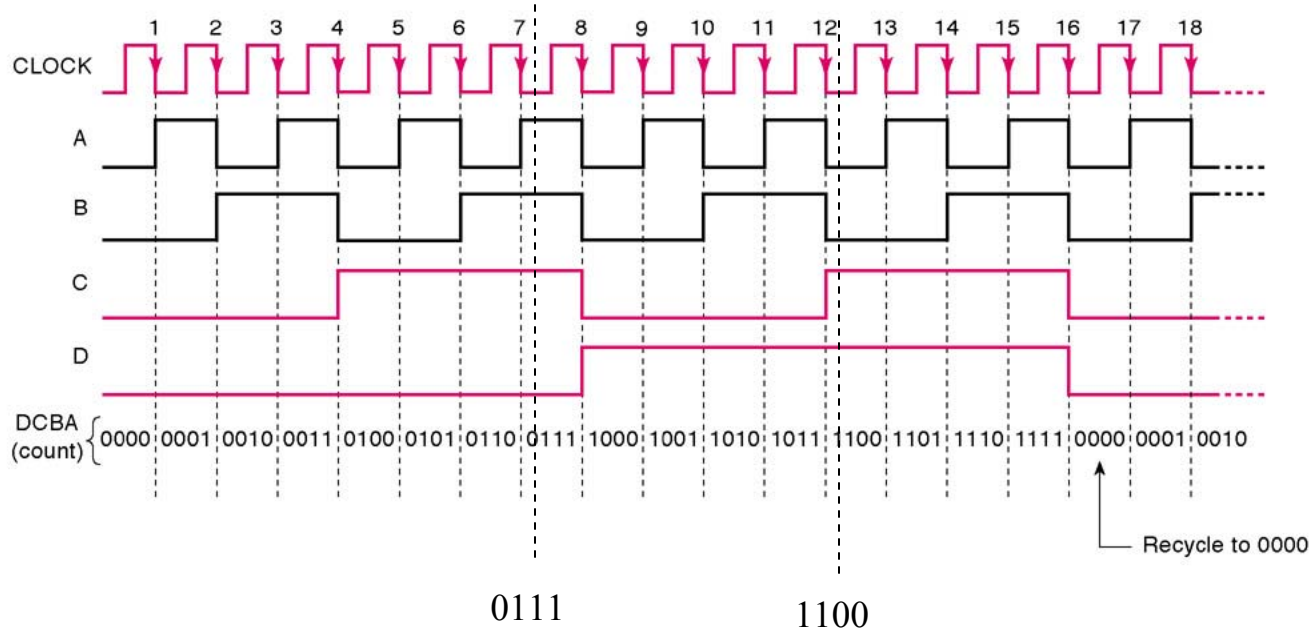

- Every trailing edge of the clock pulse changes the state of FF; hence, the output frequency of FF is half the clock frequency. Because this output is used as a clock for the next FF, the frequency is again divided by 2, and so on down the counter.
- Each FF output drives the CLK input of the next FF.
- FFs do not change states in exact synchronism with the applied clock pulses.
- There is delay between the responses of successive FFs.
- It is also often referred to as a ripple counter due to the way the FFs respond one after another in a kind of rippling effect.

MOD Number

- The counter in previous Figure has 16 distinct states, therefore, it is a MOD-16 ripple counter.
- The MOD number can be increased simply by adding more FFs to the counter. That is MOD number = 2^N
- A counter is needed that will count the number of items passing on a conveyor belt. A photocell and light source combination is used to generate a single pulse each time an item crosses its path. The counter must be able to count as many as one thousand items. How many FFs are required?

Frequency Division

In any counter, the signal at the output of the last FF will have a frequency equal to the input clock frequency divided by the MOD number of the counter. Such circuits are known as divide-by-N counters.

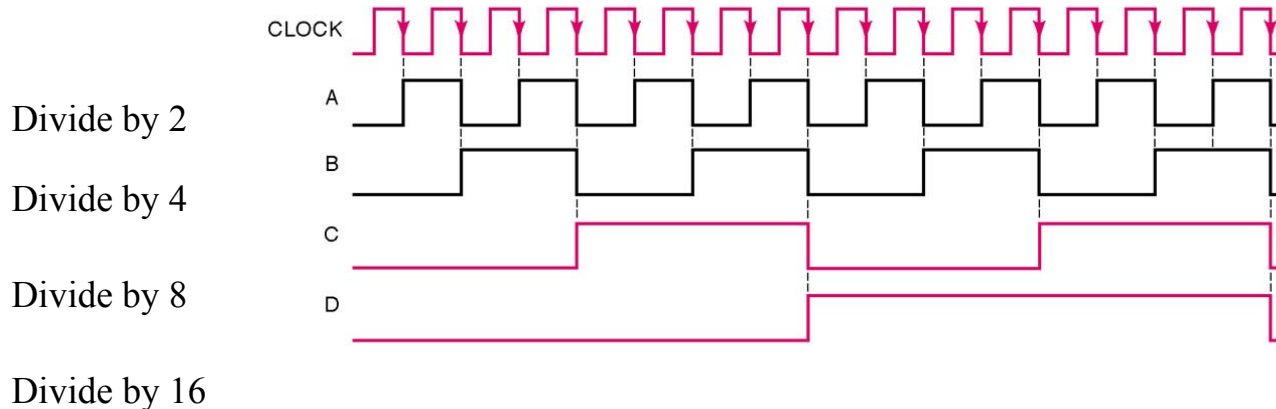

Digital Clock: The first step involved in building a digital clock is to take the 60-Hz signal and feed it into a Schmitt-trigger, pulse-shaping circuit to produce a square wave as illustrated in the following Figure. The 60 Hz square wave is then put into a MOD-60 counter, which is used to divide the 60-Hz frequency by 60 to produce a 1-Hz waveform. This 1-Hz waveform is fed to a series of counters, which then count seconds, minutes, hours, and so on.

By the way, how many FFs are required for the MOD-60 counter?

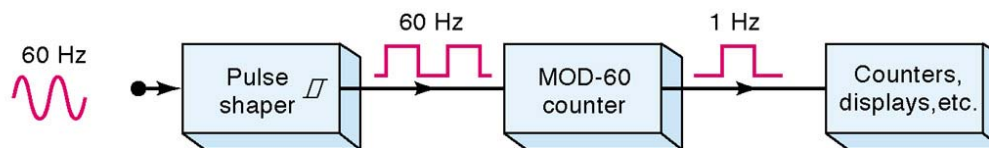

Decade Counters/BCD Counters

- Decade counter: Any counter has 10 distinct states, no matter what the sequence.
- BCD counter: A decade counter counts in sequence from 0000(zero) through 1001(decimal 9).

MOD-60 Counter

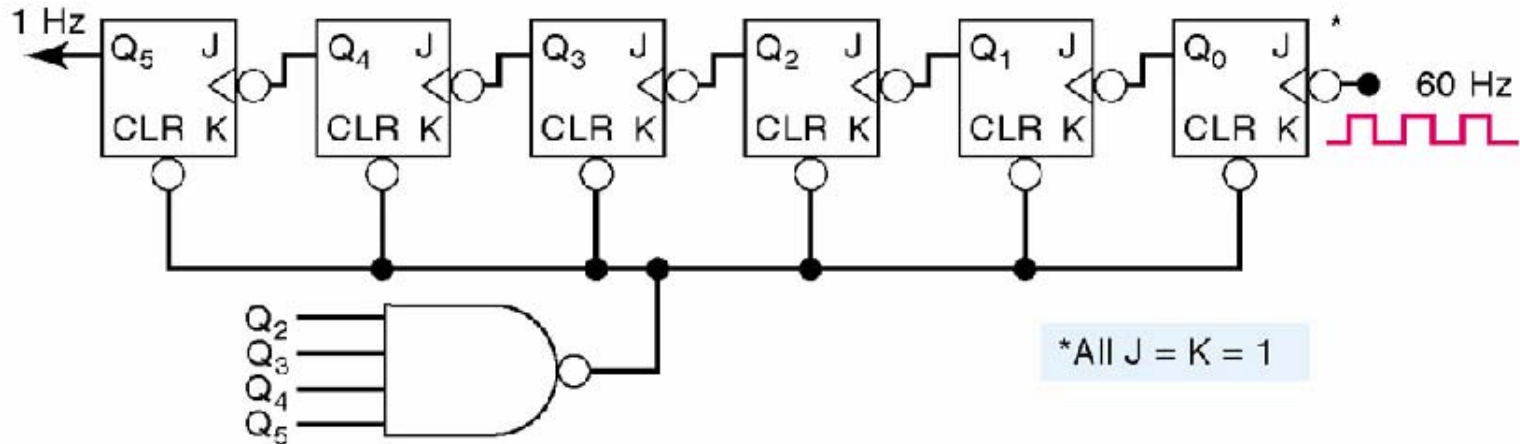

IC Asynchronous Counters

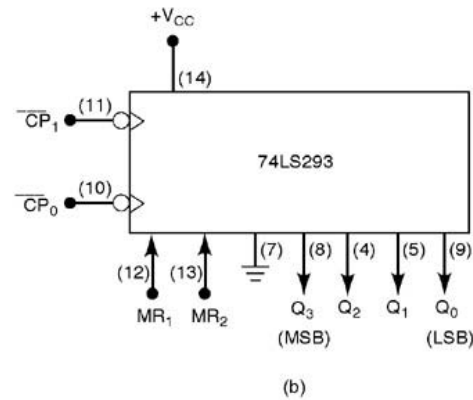
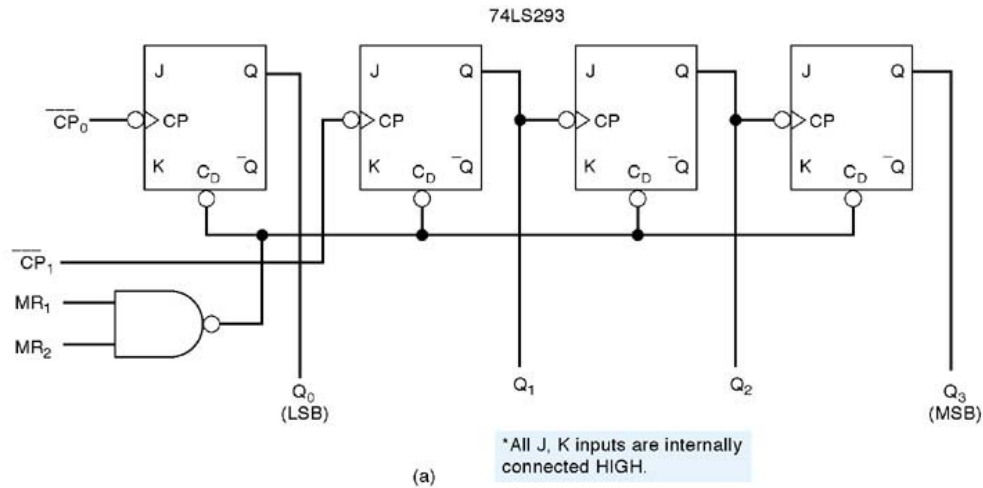

A 4-Bit Parallel Register

A register is a group of storage elements read or written as a unit. The simplest way to construct a register is by grouping together as many D flip-flops as the need to obtain

Copyright © The McGraw-Hill Companies, Inc. Permission required for reproduction or display.

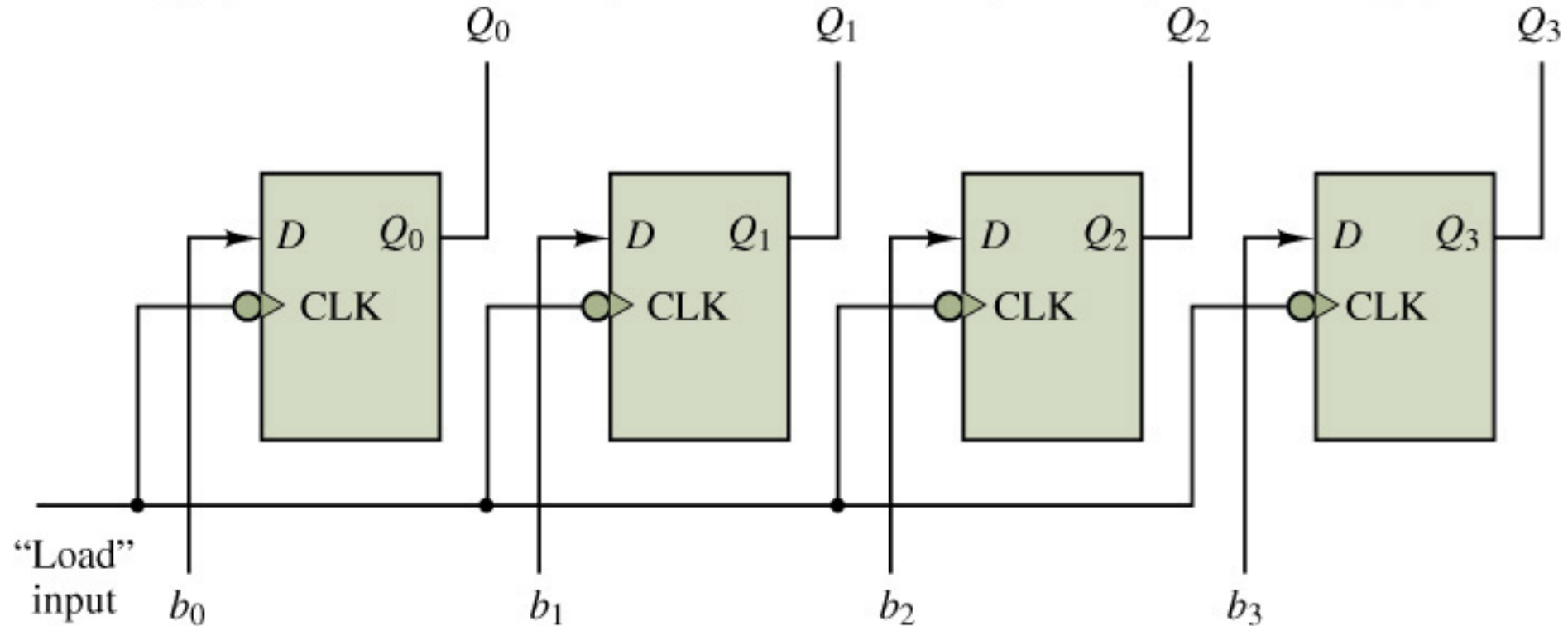

Structure of a Digital Data Acquisition and Control System

0

Copyright © The McGraw-Hill Companies, Inc. Permission required for reproduction or display.

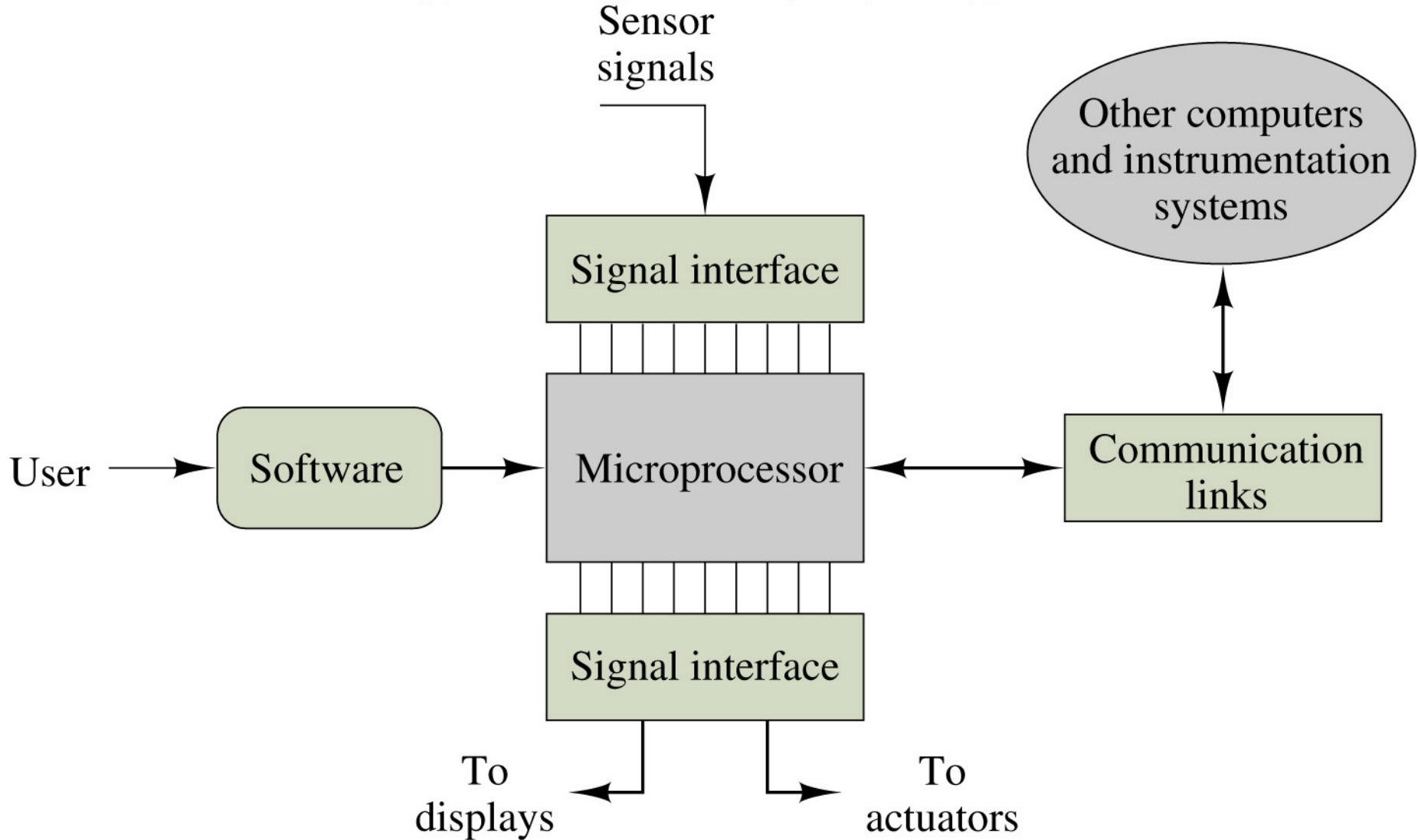

Microcontrollers, as the name suggests, are small controllers. They are like single chip computers that are often embedded into other systems to function as processing/controlling unit. For example, the remote control has microcontrollers inside that do decoding and other controlling functions. They are also used in automobiles, washing machines, microwave ovens, toys ... etc, where automation is needed.

See to the right

- (a) High-level block diagram of microcontroller;**
- (b) internal organization of microcontroller**

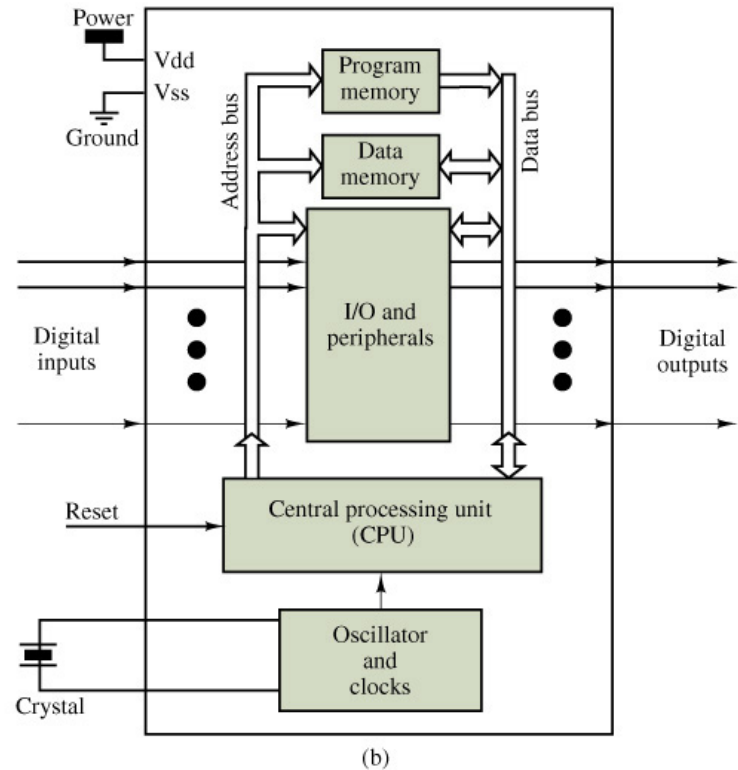
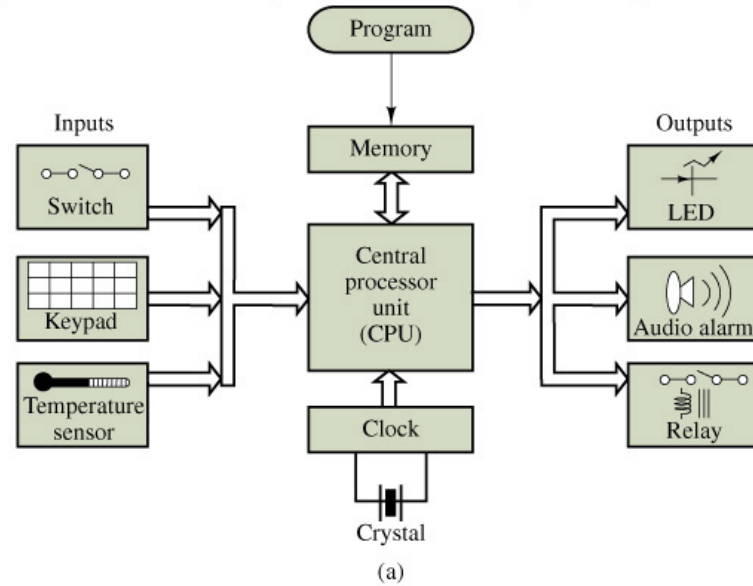

Applications in Mechatronics

Mechatronics is an interdisciplinary area of engineering that combines mechanical and electrical engineering and computer science. A typical mechatronic system picks up signals from the environment, processes them to generate output signals, transforming them for example into forces, motions and actions.

You find applications of mechatronics in:

Aircraft: Flight control and navigation system

Automobile: Electrical fuel injection, antilock brake system, digitally controlled combustion engines, and automated guided vehicles .

Automated manufacturing and robots

Home appliances

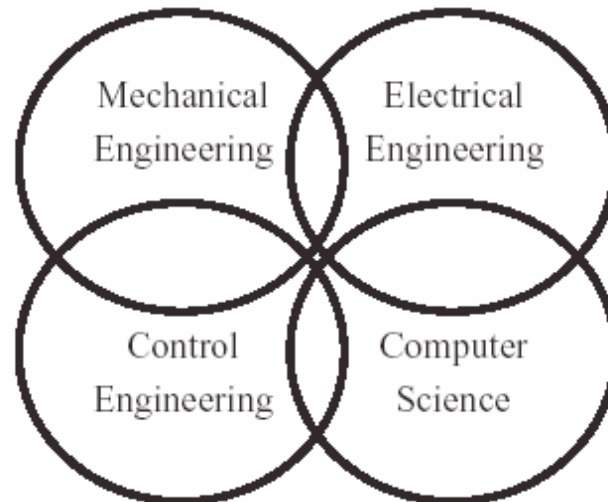

- The simplest definition of “mechatronics” is that it is a branch of engineering that deals with combined mechanical, electronic and software systems.
- The elements of mechatronics systems include sensors, actuators, microcontrollers (or microprocessors) and real-time control software.
- The actuators are mainly high precision electric motors and solenoids. Any of a large number of sensor types are used according to the intended application, including light, acceleration, weight, color, temperature and image.
- One of the features which distinguishes mechatronic systems or products from earlier electromechanical systems or products is the replacement of some mechanical functions with electronic and software ones. This results in much greater flexibility of both design and operation.
- Another is increased speed and precision of performance. A third is the ability to conduct automated data collection and reporting. In addition, advanced mechatronics systems now have the ability to implement distributed control in complex systems.

Example of Mechatronic Systems

Photocopy Machine

- **Analog Circuits:** Controlling lamps, heaters, and power circuits.
- **Digital Circuits:** Digital displays, indicator lights, buttons, and switches.
- **Microprocessor:** Coordinating all the functions of the machine.
- **Optical Sensors and Microswitches:** Detecting the presence or absence of papers and proper positioning of papers, doors and latches.
- **Encoder:** Tracking motor rotation.
- **Servo and Stepper Motors:** Loading and transporting the paper, turning the drum, and indexing the sorter.

Hard Disk: A Mechatronic System

A hard disk uses round, flat disks called *platters*, coated on both sides with a special *media* material designed to store information in the form of magnetic patterns. The platters are mounted by cutting a hole in the center and stacking them onto a *spindle*. The platters rotate at high speed, driven by a special *spindle motor* connected to the spindle. Special electromagnetic read/write devices called *heads* are mounted onto *sliders* and used to either record information onto the disk or read information from it. The sliders are mounted onto *arms*, all of which are mechanically connected into a single assembly and positioned over the surface of the disk by a device called an *actuator*. A *logic board* controls the activity of the other components and communicates with the rest of the computer.

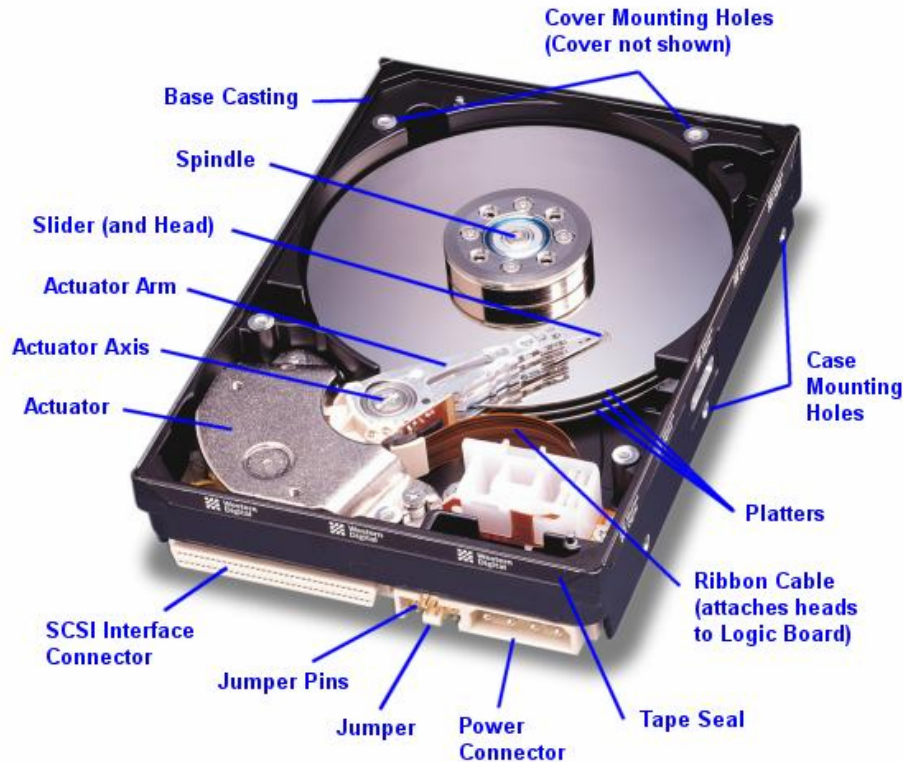

<http://www.storagereview.com/guide2000/ref/hdd/op/over.html>

