

---

E.1	Introduction	E-2
E.2	Interconnecting Two Devices	E-5
E.3	Connecting More than Two Devices	E-20
E.4	Network Topology	E-29
E.5	Network Routing, Arbitration, and Switching	E-45
E.6	Switch Microarchitecture	E-55
E.7	Practical Issues for Commercial Interconnection Networks	E-62
E.8	Examples of Interconnection Networks	E-70
E.9	Internetworking	E-80
E.10	Crosscutting Issues for Interconnection Networks	E-85
E.11	Fallacies and Pitfalls	E-88
E.12	Concluding Remarks	E-96
E.13	Historical Perspective and References	E-97
	Exercises	E-107

# E

## Interconnection Networks

**Revised by Timothy M. Pinkston, University of Southern California, and José Duato, Universitat Politècnica de València, and Simula**

“The Medium is the Message” because it is the medium that shapes and controls the search and form of human associations and actions.

**Marshall McLuhan**

*Understanding Media* (1964)

The marvels—of film, radio, and television—are marvels of one-way communication, which is not communication at all.

**Milton Mayer**

*On the Remote Possibility of Communication* (1967)

The interconnection network is the heart of parallel architecture.

**Chuan-Lin Wu and Tse-Yun Feng**

*Interconnection Networks for Parallel and Distributed Processing* (1984)

Indeed, as system complexity and integration continues to increase, many designers are finding it more efficient to route packets, not wires.

**Bill Dally**

*Principles and Practices of Interconnection Networks* (2004)

## E.1 Introduction

Previous chapters and appendices cover the components of a single computer but give little consideration to the interconnection of those components and how multiple computer systems are interconnected. These aspects of computer architecture have gained significant importance in recent years. In this appendix we see how to connect individual devices together into a community of communicating devices, where the term *device* is generically used to signify anything from a component or set of components within a computer to a single computer to a system of computers. Figure E.1 shows the various elements comprising this community: end nodes consisting of devices and their associated hardware and software interfaces, links from end nodes to the interconnection network, and the interconnection network. Interconnection networks are also called *networks*, *communication subnets*, or *communication subsystems*. The interconnection of multiple networks is called *internetworking*. This relies on communication standards to convert information from one kind of network to another, such as with the Internet.

There are several reasons why computer architects should devote attention to interconnection networks. In addition to providing external connectivity, networks are commonly used to interconnect the components within a single computer at many levels, including the processor microarchitecture. Networks have long been used in mainframes, but today such designs can be found in personal computers as well, given the high demand on communication bandwidth needed to enable increased computing power and storage capacity. Switched networks are replacing buses as the normal means of communication between computers, between I/O devices, between boards, between chips, and even between modules inside chips. Computer architects must understand interconnect problems and solutions in order to more effectively design and evaluate computer systems.

Interconnection networks cover a wide range of application domains, very much like memory hierarchy covers a wide range of speeds and sizes. Networks implemented within processor chips and systems tend to share characteristics much in common with processors and memory, relying more on high-speed hardware solutions and less on a flexible software stack. Networks implemented across systems tend to share much in common with storage and I/O, relying more on the operating system and software protocols than high-speed hardware—though we are seeing a convergence these days. Across the domains, performance includes latency and effective bandwidth, and queuing theory is a valuable analytical tool in evaluating performance, along with simulation techniques.

This topic is vast—portions of Figure E.1 are the subject of entire books and college courses. The goal of this appendix is to provide for the computer architect an overview of network problems and solutions. This appendix gives introductory explanations of key concepts and ideas, presents architectural implications of interconnection network technology and techniques, and provides useful references to more detailed descriptions. It also gives a common framework for evaluating all types of interconnection networks, using a single set of terms to describe

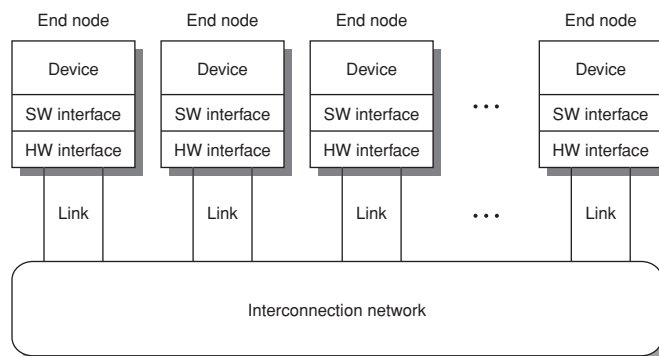

**Figure E.1** A conceptual illustration of an interconnected community of devices.

the basic alternatives. As we will see, many types of networks have common preferred alternatives, but for others the best solutions are quite different. These differences become very apparent when crossing between the networking domains.

## Interconnection Network Domains

Interconnection networks are designed for use at different levels within and across computer systems to meet the operational demands of various application areas—high-performance computing, storage I/O, cluster/workgroup/enterprise systems, internetworking, and so on. Depending on the number of devices to be connected and their proximity, we can group interconnection networks into four major networking domains:

- *On-chip networks (OCNs)*—Also referred to as network-on-chip (NoC), this type of network is used for interconnecting microarchitecture functional units, register files, caches, compute tiles, and processor and IP cores within chips or multichip modules. Currently, OCNs support the connection of up to only a few tens of such devices with a maximum interconnection distance on the order of centimeters. Most OCNs used in high-performance chips are custom designed to mitigate chip-crossing wire delay problems caused by increased technology scaling and transistor integration, though some proprietary designs are gaining wider use (e.g., IBM’s CoreConnect, ARM’s AMBA, and Sonic’s Smart Interconnect). An example custom OCN is the *Element Interconnect Bus* used in the Cell Broadband Engine processor chip. This network peaks at ~2400 Gbps (for a 3.2 GHz processor clock) for 12 elements on the chip.
- *System/storage area networks (SANs)*—This type of network is used for interprocessor and processor-memory interconnections within multiprocessor and multicomputer systems, and also for the connection of storage and I/O components within server and data center environments. Typically, several

hundreds of such devices can be connected, although some supercomputer SANs support the interconnection of many thousands of devices, like the IBM Blue Gene/L supercomputer. The maximum interconnection distance covers a relatively small area—on the order of a few tens of meters usually—but some SANs have distances spanning a few hundred meters. For example, *InfiniBand*, a popular SAN standard introduced in late 2000, supports system and storage I/O interconnects at up to 120 Gbps over a distance of 300 m.

- *Local area networks (LANs)*—This type of network is used for interconnecting autonomous computer systems distributed across a machine room or throughout a building or campus environment. Interconnecting PCs in a cluster is a prime example. Originally, LANs connected only up to a hundred devices, but with bridging, LANs can now connect up to a few thousand devices. The maximum interconnect distance covers an area of a few kilometers usually, but some have distance spans of a few tens of kilometers. For instance, the most popular and enduring LAN, *Ethernet*, has a 10 Gbps standard version that supports maximum performance over a distance of 40 km.
- *Wide area networks (WANs)*—Also called *long-haul networks*, WANs connect computer systems distributed across the globe, which requires internetworking support. WANs connect many millions of computers over distance scales of many thousands of kilometers. ATM is an example of a WAN.

Figure E.2 roughly shows the relationship of these networking domains in terms of the number of devices interconnected and their distance scales. Overlap exists for some of these networks in one or both dimensions, which leads to prod-

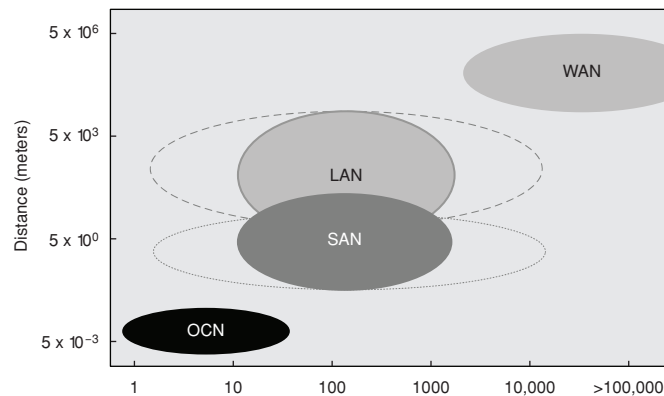

**Figure E.2** Relationship of the four interconnection network domains in terms of number of devices connected and their distance scales: on-chip network (OCN), system/storage area network (SAN), local area network (LAN), and wide area network (WAN). Note that there are overlapping ranges where some of these networks compete. Some supercomputer systems use proprietary custom networks to interconnect several thousands of computers, while other systems, such as multicomputer clusters, use standard commercial networks.

uct competition. Some network solutions have become commercial standards while others remain proprietary. Although the preferred solutions may significantly differ from one interconnection network domain to another depending on the design requirements, the problems and concepts used to address network problems remain remarkably similar across the domains. No matter the target domain, networks should be designed so as not to be the bottleneck to system performance and cost efficiency. Hence, the ultimate goal of computer architects is to design interconnection networks of the lowest possible cost that are capable of transferring the maximum amount of available information in the shortest possible time.

## Approach and Organization of This Appendix

Interconnection networks can be well understood by taking a top-down approach to unveiling the concepts and complexities involved in designing them. We do this by viewing the network initially as an opaque “black box” that simply and ideally performs certain necessary functions. Then we systematically open various layers of the black box, allowing more complex concepts and nonideal network behavior to be revealed. We begin this discussion by first considering the interconnection of just two devices in Section E.2, where the black box network can be viewed as a simple *dedicated link* network—that is, wires or collections of wires running bidirectionally between the devices. We then consider the interconnection of more than two devices in Section E.3, where the black box network can be viewed as a *shared link* network or as a *switched point-to-point* network connecting the devices. We continue to peel away various other layers of the black box by considering in more detail the network topology (Section E.4), routing, arbitration, and switching (Section E.5), and switch microarchitecture (Section E.6). Practical issues for commercial networks are considered in Section E.7, followed by examples illustrating the trade-offs for each type of network in Section E.8. Internetworking is briefly discussed in Section E.9, and additional crosscutting issues for interconnection networks are presented in Section E.10. Section E.11 gives some common fallacies and pitfalls related to interconnection networks, and Section E.12 presents some concluding remarks. Finally, we provide a brief historical perspective and some suggested reading in Section E.13.

---

## E.2

## Interconnecting Two Devices

This section introduces the basic concepts required to understand how communication between just two networked devices takes place. This includes concepts that deal with situations in which the receiver may not be ready to process incoming data from the sender and situations in which transport errors may occur. To ease understanding, the black box network at this point can be conceptualized as an ideal network that behaves as simple dedicated links between the two devices.

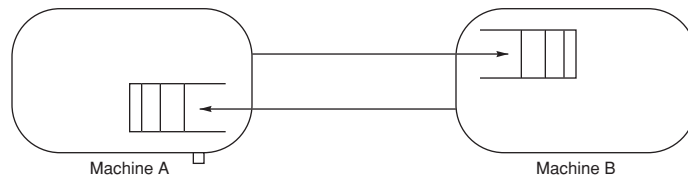

**Figure E.3** A simple dedicated link network bidirectionally interconnecting two devices.

Figure E.3 illustrates this, where unidirectional wires run from device A to device B and vice versa, and each end node contains a buffer to hold the data. Regardless of the network complexity, whether dedicated link or not, a connection exists from each end node device to the network to inject and receive information to/from the network. We first describe the basic functions that must be performed at the end nodes to commence and complete communication, and then we discuss network media and the basic functions that must be performed by the network to carry out communication. Later, a simple performance model is given, along with several examples to highlight implications of key network parameters.

## Network Interface Functions: Composing and Processing Messages

Suppose we want two networked devices to read a word from each other's memory. The unit of information sent or received is called a *message*. To acquire the desired data, the two devices must first compose and send a certain type of message in the form of a *request* containing the address of the data within the other device. The address (i.e., memory or operand location) allows the receiver to identify where to find the information being requested. After processing the request, each device then composes and sends another type of message, a *reply*, containing the data. The address and data information is typically referred to as the message *payload*.

In addition to payload, every message contains some control bits needed by the network to deliver the message and process it at the receiver. The most typical are bits to distinguish between different types of messages (i.e., request, reply, request acknowledge, reply acknowledge, etc.) and bits that allow the network to transport the information properly to the destination. These additional control bits are encoded in the *header* and/or *trailer* portions of the message, depending on their location relative to the message payload. As an example, Figure E.4 shows the format of a message for the simple dedicated link network shown in Figure E.3. This example shows a single-word payload, but messages in some interconnection networks can include several thousands of words.

Before message transport over the network occurs, messages have to be composed. Likewise, upon receipt from the network, they must be processed. These and other functions described below are the role of the *network interface* (also



**Figure E.4** An example packet format with header, payload, and checksum in the trailer.

referred to as the *channel adapter*) residing at the end nodes. Together with some DMA engine and link drivers to transmit/receive messages to/from the network, some dedicated memory or register(s) may be used to buffer outgoing and incoming messages. Depending on the network domain and design specifications for the network, the network interface hardware may consist of nothing more than the communicating device itself (i.e., for OCNs and some SANs) or a separate card that integrates several embedded processors and DMA engines with thousands of megabytes of RAM (i.e., for many SANs and most LANs and WANs).

In addition to hardware, network interfaces can include software or firmware to perform the needed operations. Even the simple example shown in Figure E.3 may invoke messaging software to translate requests and replies into messages with the appropriate headers. This way, user applications need not worry about composing and processing messages as these tasks can be performed automatically at a lower level. An application program usually cooperates with the operating or run time system to send and receive messages. As the network is likely to be shared by the processes running on each device, the operating system cannot allow messages intended for one process to be received by another. Thus, the messaging software must include protection mechanisms that distinguish between processes. This distinction could be made by expanding the header with a *port* number that is known by both the sender and intended receiver processes.

In addition to composing and processing messages, additional functions need to be performed by the end nodes to establish communication among the communicating devices. Although hardware support can reduce the amount of work, some can be done by software. For example, most networks specify a maximum amount of information that can be transferred (i.e., *maximum transfer unit*) so that network buffers can be dimensioned appropriately. Messages longer than the maximum transfer unit are divided into smaller units, called



*packets* (or *datagrams*), that are transported over the network. Packets are reassembled into messages at the destination end node before delivery to the application. Packets belonging to the same message can be distinguished from others by including a *message ID* field in the packet header. If packets arrive out of order at the destination, they are reordered when reassembled into a message. Another field in the packet header containing a *sequence number* is usually used for this purpose.

The sequence of steps the end node follows to commence and complete communication over the network is called a *communication protocol*. It generally has symmetric but reversed steps between sending and receiving information. Communication protocols are implemented by a combination of software and hardware to accelerate execution. For instance, many network interface cards implement hardware timers as well as hardware support to split messages into packets and reassemble them, compute the cyclic redundancy check (CRC) *checksum*, handle virtual memory addresses, and so on.

Some network interfaces include extra hardware to offload protocol processing from the host computer, such as TCP *offload engines* for LANs and WANs. But for interconnection networks such as SANs that have low latency requirements, this may not be enough even when lighter-weight communication protocols are used such as message passing interface (MPI). Communication performance can be further improved by bypassing the operating system (OS). OS-bypassing can be implemented by directly allocating message buffers in the network interface memory so that applications directly write into and read from those buffers. This avoids extra memory-to-memory copies. The corresponding protocols are referred to as *zero-copy* protocols or *user-level communication* protocols. Protection can still be maintained by calling the OS to allocate those buffers at initialization and preventing unauthorized memory accesses in hardware.

In general, some or all of the following are the steps needed to send a message at end node devices over a network:

1. The application executes a system call, which copies data to be sent into an operating system or network interface buffer, divides the message into packets (if needed), and composes the header and trailer for packets.
2. The checksum is calculated and included in the header or trailer of packets.
3. The timer is started, and the network interface hardware sends the packets.

Message reception is in the reverse order:

3. The network interface hardware receives the packets and puts them into its buffer or the operating system buffer.
2. The checksum is calculated for each packet. If the checksum matches the sender's checksum, the receiver sends an acknowledgment back to the packet sender. If not, it deletes the packet, assuming that the sender will resend the packet when the associated timer expires.
1. Once all packets pass the test, the system reassembles the message, copies the data to the user's address space, and signals the corresponding application.

The sender must still react to packet acknowledgments:

- When the sender gets an acknowledgment, it releases the copy of the corresponding packet from the buffer.
- If the sender reaches the time-out instead of receiving an acknowledgment, it resends the packet and restarts the timer.

Just as a protocol is implemented at network end nodes to support communication, protocols are also used across the network structure at the physical, data link, and network layers responsible primarily for packet transport, flow control, error handling, and other functions described next.

### Basic Network Structure and Functions: Media and Form Factor, Packet Transport, Flow Control, and Error Handling

Once a packet is ready for transmission at its source, it is injected into the network using some dedicated hardware at the network interface. The hardware includes some transceiver circuits to drive the physical network media—either electrical or optical. The type of *media* and *form factor* depends largely on the interconnect distances over which certain signaling rates (i.e., transmission speed) should be sustainable. For centimeter or less distances on a chip or multi-chip module, typically the middle to upper copper metal layers can be used for interconnects at multi-Gbps signaling rates per line. A dozen or more layers of copper traces or tracks imprinted on circuit boards, midplanes, and backplanes can be used for Gbps differential-pair signaling rates at distances of about a meter or so. Category 5E unshielded twisted-pair copper wiring allows 0.25 Gbps transmission speed over distances of 100 meters. Coaxial copper cables can deliver 10 Mbps over kilometer distances. In these conductor lines, distance can usually be traded off for higher transmission speed, up to a certain point. Optical media enable faster transmission speeds at distances of kilometers. Multimode fiber supports 100 Mbps transmission rates over a few kilometers, and more expensive single-mode fiber supports Gbps transmission speeds over distances of several kilometers. Wavelength division multiplexing allows several times more bandwidth to be achieved in fiber (i.e., by a factor of the number of wavelengths used).

The hardware used to drive network links may also include some encoders to encode the signal in a format other than binary that is suitable for the given transport distance. Encoding techniques can use multiple voltage levels, redundancy, data and control rotation (e.g., 4b5b encoding), and/or a guaranteed minimum number of signal transitions per unit time to allow for clock recovery at the receiver. The signal is decoded at the receiver end, and the packet is stored in the corresponding buffer. All of these operations are performed at the network physical layer, the details of which are beyond the scope of this appendix. Fortunately, we do not need to worry about them. From the perspective of the data link and higher layers, the physical layer can be viewed as a long linear pipeline without staging in which signals propagate as waves through the network transmission medium. All of the above functions are generally referred to as *packet transport*.

Besides packet transport, the network hardware and software are jointly responsible at the data link and network protocol layers for ensuring reliable delivery of packets. These responsibilities include (1) preventing the sender from sending packets at a faster rate than they can be processed by the receiver and (2) ensuring that the packet is neither garbled nor lost in transit. The first responsibility is met by either discarding packets at the receiver when its buffer is full and later notifying the sender to retransmit them, or by notifying the sender to stop sending packets when the buffer becomes full and to resume later once it has room for more packets. The latter strategy is generally known as *flow control*.

There are several interesting techniques commonly used to implement flow control beyond simple *handshaking* between the sender and receiver. The more popular techniques are *Xon/Xoff* (also referred to as *Stop & Go*) and *credit-based* flow control. *Xon/Xoff* consists of the receiver notifying the sender either to stop or to resume sending packets once high and low buffer occupancy levels are reached, respectively, with some hysteresis to reduce the number of notifications. Notifications are sent as “stop” and “go” signals using additional control wires or encoded in control packets. Credit-based flow control typically uses a credit counter at the sender that initially contains a number of credits equal to the number of buffers at the receiver. Every time a packet is transmitted, the sender decrements the credit counter. When the receiver consumes a packet from its buffer, it returns a credit to the sender in the form of a control packet that notifies the sender to increment its counter upon receipt of the credit. These techniques essentially control the flow of packets into the network by *throttling* packet injection at the sender when the receiver reaches a low watermark or when the sender runs out of credits.

*Xon/Xoff* usually generates much less control traffic than credit-based flow control because notifications are only sent when the high or low buffer occupancy levels are crossed. On the other hand, credit-based flow control requires less than half the buffer size required by *Xon/Xoff*. Buffers for *Xon/Xoff* must be large enough to prevent overflow before the “stop” control signal reaches the sender. Overflow cannot happen when using credit-based flow control because the sender will run out of credits, thus stopping transmission. For both schemes, full link bandwidth utilization is possible only if buffers are large enough for the distance over which communication takes place.

Let's compare the buffering requirements of the two flow control techniques in a simple example covering the various interconnection network domains.

---

**Example** Suppose we have a dedicated-link network with a raw data bandwidth of 8 Gbps for each link in each direction interconnecting two devices. Packets of 100 bytes (including the header) are continuously transmitted from one device to the other to fully utilize network bandwidth. What is the minimum amount of credits and buffer space required by credit-based flow control assuming interconnect distances of 1 cm, 1 m, 100 m, and 10 km if only link propagation delay is taken into account? How does the minimum buffer space compare against *Xon/Xoff*?

**Answer** At the start, the receiver buffer is initially empty and the sender contains a number of credits equal to buffer capacity. The sender will consume a credit every time a packet is transmitted. For the sender to continue transmitting packets at network speed, the first returned credit must reach the sender before the sender runs out of credits. After receiving the first credit, the sender will keep receiving credits at the same rate it transmits packets. As we are considering only propagation delay over the link and no other sources of delay or overhead, null processing time at the sender and receiver are assumed. The time required for the first credit to reach the sender since it started transmission of the first packet is equal to the round-trip propagation delay for the packet transmitted to the receiver and the return credit transmitted back to the sender. This time must be less than or equal to the packet transmission time multiplied by the initial credit count:

$$\text{Packet propagation delay} + \text{Credit propagation delay} \leq \frac{\text{Packet size}}{\text{Bandwidth}} \times \text{Credit count}$$

The speed of light is about 300,000 km/sec. Assume we can achieve 66% of that in a conductor. Thus, the minimum number of credits for each distance is given by

$$\left( \frac{\text{Distance}}{2/3 \times 300,000 \text{ km/sec}} \right) \times 2 \leq \frac{100 \text{ bytes}}{8 \text{ Gbits/sec}} \times \text{Credit count}$$

As each credit represents one packet-sized buffer entry, the minimum amount of credits (and, likewise, buffer space) needed by each device is one for the 1 cm and 1 m distances, 10 for the 10 m distance, and 1000 packets for the 10 km distance. For Xon/Xoff, this minimum buffer size corresponds to the buffer fragment from the high occupancy level to the top of the buffer and from the low occupancy level to the bottom of the buffer. With the added hysteresis between both occupancy levels to reduce notifications, the minimum buffer space for Xon/Xoff turns out to be more than twice that for credit-based flow control.

---

Networks that implement flow control do not need to drop packets and are sometimes referred to as *lossless* networks; networks that drop packets are sometimes referred to as *lossy* networks. This single difference in the way packets are handled by the network drastically constrains the kinds of solutions that can be implemented to address other related network problems, including packet routing, congestion, deadlock, and reliability, as we will see later in this appendix. This difference also affects performance significantly as dropped packets need to be retransmitted, thus consuming more link bandwidth and suffering extra delay. These behavioral and performance differences ultimately restrict the interconnection network domains for which certain solutions are applicable. For instance, most networks delivering packets over relatively short distances (e.g., OCNs and SANs) tend to implement flow control; on the other hand, networks delivering packets over relatively long distances (e.g., LANs and WANs) tend to be designed to drop packets. For the shorter distances, the delay in propagating flow control information back to the sender can be negligible, but not so for longer distance scales. The kinds of applications that are usually run also influence the

choice of lossless versus lossy networks. For instance, dropping packets sent by an Internet client like a Web browser affects only the delay observed by the corresponding user. However, dropping a packet sent by a process from a parallel application may lead to a significant increase in the overall execution time of the application if that packet's delay is on the critical path.

The second responsibility of ensuring that packets are neither garbled nor lost in transit can be met by implementing some mechanisms to detect and recover from transport errors. Adding a checksum or some other error detection field to the packet format, as shown in Figure E.4, allows the receiver to detect errors. This redundant information is calculated when the packet is sent and checked upon receipt. The receiver then sends an acknowledgment in the form of a control packet if the packet passes the test. Note that this acknowledgment control packet may simultaneously contain flow control information (e.g., a credit or stop signal), thus reducing control packet overhead. As described earlier, the most common way to recover from errors is to have a timer record the time each packet is sent and to presume the packet is lost or erroneously transported if the timer expires before an acknowledgment arrives. The packet is then resent.

The communication protocol across the network and network end nodes must handle many more issues other than packet transport, flow control, and reliability. For example, if two devices are from different manufacturers, they might order bytes differently within a word (Big Endian versus Little Endian byte ordering). The protocol must reverse the order of bytes in each word as part of the delivery system. It must also guard against the possibility of duplicate packets if a delayed packet were to become unstuck. Depending on the system requirements, the protocol may have to implement *pipelining* among operations to improve performance. Finally, the protocol may need to handle network congestion to prevent performance degradation when more than two devices are connected, as described later in Section E.7.

## Characterizing Performance: Latency and Effective Bandwidth

Now that we have covered the basic steps for sending and receiving messages between two devices, we can discuss performance. We start by discussing the latency when transporting a single packet. Then we discuss the effective bandwidth (also known as throughput) that can be achieved when the transmission of multiple packets is pipelined over the network at the packet level.

Figure E.5 shows the basic components of latency for a single packet. Note that some latency components will be broken down further in later sections as the internals of the “black box” network are revealed. The timing parameters in Figure E.5 apply to many interconnection network domains: inside a chip, between chips on a board, between boards in a chassis, between chassis within a computer, between computers in a cluster, between clusters, and so on. The values may change, but the components of latency remain the same.

The following terms are often used loosely, leading to confusion, so we define them here more precisely:

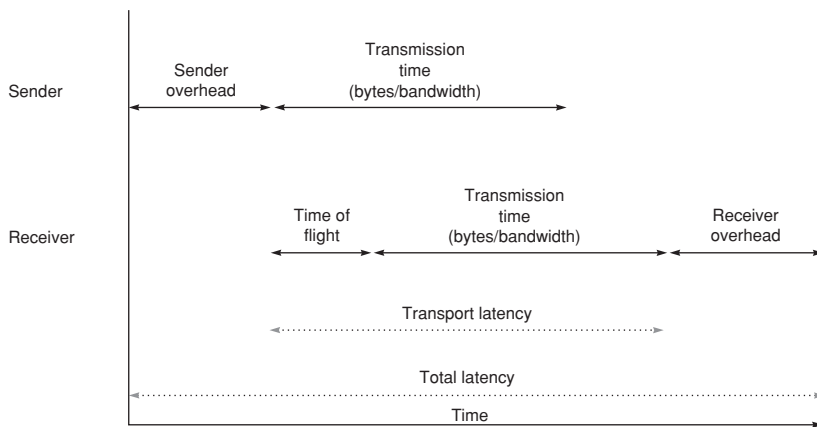

**Figure E.5 Components of packet latency.** Depending on whether it is an OCN, SAN, LAN, or WAN, the relative amounts of sending and receiving overhead, time of flight, and transmission time are usually quite different from those illustrated here.

- *Bandwidth*—Strictly speaking, the *bandwidth* of a transmission medium refers to the range of frequencies for which the attenuation per unit length introduced by that medium is below a certain threshold. It must be distinguished from the *transmission speed*, which is the amount of information transmitted over a medium per unit time. For example, modems successfully increased transmission speed in the late 1990s for a fixed bandwidth (i.e., the 3 KHz bandwidth provided by voice channels over telephone lines) by encoding more voltage levels and, hence, more bits per signal cycle. However, to be consistent with its more widely understood meaning, we use the term *bandwidth* to refer to the maximum rate at which information can be transferred, where information includes packet header, payload, and trailer. The units are traditionally bits per second although bytes per second is sometimes used. The term *bandwidth* is also used to mean the measured speed of the medium (i.e., network links). *Aggregate bandwidth* refers to the total data bandwidth supplied by the network, and *effective bandwidth* or *throughput* is the fraction of aggregate bandwidth delivered by the network to an application.
- *Time of flight*—This is the time for the first bit of the packet to arrive at the receiver, including the propagation delay over the links and delays due to other hardware in the network such as link repeaters and network switches. The unit of measure for time of flight can be in milliseconds for WANs, microseconds for LANs, nanoseconds for SANs, and picoseconds for OCNs.
- *Transmission time*—This is the time for the packet to pass through the network, not including time of flight. One way to measure it is the difference in time between when the first bit of the packet arrives at the receiver and when the last bit of that packet arrives at the receiver. By definition, transmission time is equal to the size of the packet divided by the data bandwidth of network links.

This measure assumes there are no other packets contending for that bandwidth (i.e., a zero-load or no-load network).

- *Transport latency*—This is the sum of time of flight and transmission time. Transport latency is the time that the packet spends in the interconnection network. Stated alternatively, it is the time between when the first bit of the packet is injected into the network and when the last bit of that packet arrives at the receiver. It does not include the overhead of preparing the packet at the sender or processing it when it arrives at the receiver.
- *Sending overhead*—This is the time for the end node to prepare the packet (as opposed to the message) for injection into the network, including both hardware and software components. Note that the end node is busy for the entire time, hence the use of the term *overhead*. Once the end node is free, any subsequent delays are considered part of the transport latency. We assume that overhead consists of a constant term plus a variable term that depends on packet size. The constant term includes memory allocation, packet header preparation, setting up DMA devices, and so on. The variable term is mostly due to copies from buffer to buffer and is usually negligible for very short packets.
- *Receiving overhead*—This is the time for the end node to process an incoming packet, including both hardware and software components. We also assume here that overhead consists of a constant term plus a variable term that depends on packet size. In general, the receiving overhead is larger than the sending overhead. For example, the receiver may pay the cost of an interrupt, or may have to reorder and reassemble packets into messages.

The total latency of a packet can be expressed algebraically by the following:

$$\text{Latency} = \text{Sending overhead} + \text{Time of flight} + \frac{\text{Packet size}}{\text{Bandwidth}} + \text{Receiving overhead}$$

Let's see how the various components of transport latency and the sending and receiving overheads change in importance as we go across the interconnection network domains: from OCNs to SANs to LANs to WANs.

---

**Example** Assume we have a dedicated link network with a data bandwidth of 8 Gbps for each link in each direction interconnecting two devices within an OCN, SAN, LAN, or WAN, and we wish to transmit packets of 100 bytes (including the header) between the devices. The end nodes have a per-packet sending overhead of  $x + 0.05$  ns/byte and receiving overhead of  $4/3(x) + 0.05$  ns/byte, where  $x$  is 0  $\mu$ s for the OCN, 0.3  $\mu$ s for the SAN, 3  $\mu$ s for the LAN, and 30  $\mu$ s for the WAN, which are typical for these network types. Calculate the total latency to send packets from one device to the other for interconnection distances of 0.5 cm, 5 m, 5000 m, and 5000 km assuming that time of flight consists only of link propagation delay (i.e., no switching or other sources of delay).

**Answer** Using the above expression and the calculation for propagation delay through a conductor given in the previous example, we can plug in the parameters for each of the networks to find their total packet latency. For the OCN:



$$\begin{aligned}\text{Latency} &= \text{Sending overhead} + \text{Time of flight} + \frac{\text{Packet size}}{\text{Bandwidth}} + \text{Receiving overhead} \\ &= 5\text{ ns} + \frac{0.5\text{ cm}}{2/3 \times 300,000\text{ km/sec}} + \frac{100\text{ bytes}}{8\text{ Gbits/sec}} + 5\text{ ns}\end{aligned}$$

Converting all terms into nanoseconds (ns) leads to the following for the OCN:

$$\begin{aligned}\text{Total latency (OCN)} &= 5\text{ ns} + \frac{0.5\text{ cm}}{2/3 \times 300,000\text{ km/sec}} + \frac{100 \times 8}{8}\text{ ns} + 5\text{ ns} \\ &= 5\text{ ns} + 0.025\text{ ns} + 100\text{ ns} + 5\text{ ns} \\ &= 110.025\text{ ns}\end{aligned}$$

Substituting in the appropriate values for the SAN gives the following latency:

$$\begin{aligned}\text{Total latency (SAN)} &= 0.305\text{ }\mu\text{s} + \frac{5\text{ m}}{2/3 \times 300,000\text{ km/sec}} + \frac{100\text{ bytes}}{8\text{ Gbits/sec}} + 0.405\text{ }\mu\text{s} \\ &= 0.305\text{ }\mu\text{s} + 0.025\text{ }\mu\text{s} + 0.1\text{ }\mu\text{s} + 0.405\text{ }\mu\text{s} \\ &= 0.835\text{ }\mu\text{s}\end{aligned}$$

Substituting in the appropriate values for the LAN gives the following latency:

$$\begin{aligned}\text{Total latency (LAN)} &= 3.005\text{ }\mu\text{s} + \frac{5\text{ km}}{2/3 \times 300,000\text{ km/sec}} + \frac{100\text{ bytes}}{8\text{ Gbits/sec}} + 4.005\text{ }\mu\text{s} \\ &= 3.005\text{ }\mu\text{s} + 25\text{ }\mu\text{s} + 0.1\text{ }\mu\text{s} + 4.005\text{ }\mu\text{s} \\ &= 32.11\text{ }\mu\text{s}\end{aligned}$$

Substituting in the appropriate values for the WAN gives the following latency:

$$\begin{aligned}\text{Total latency (WAN)} &= 30.005\text{ }\mu\text{s} + \frac{5000\text{ km}}{2/3 \times 300,000\text{ km/sec}} + \frac{100\text{ bytes}}{8\text{ Gbits/sec}} + 40.005\text{ }\mu\text{s} \\ &= 30.005\text{ }\mu\text{s} + 25000\text{ }\mu\text{s} + 0.1\text{ }\mu\text{s} + 40.005\text{ }\mu\text{s} \\ &= 25.07\text{ ms}\end{aligned}$$

---

The increased fraction of the latency required by time of flight for the longer distances along with the greater likelihood of errors over the longer distances are among the reasons why WANs and LANs use more sophisticated and time-consuming communication protocols, which increase sending and receiving overheads. The need for standardization is another reason. Complexity also increases due to the requirements imposed on the protocol by the typical applications that run over the various interconnection network domains as we go from tens to hundreds to thousands to many thousands of devices. We will consider this in later sections when we discuss connecting more than two devices. The above example shows that the propagation delay component of time of flight for WANs and some LANs is so long that other latency components—including the sending and receiving overheads—can practically be ignored. This is not so for SANs and OCNs where the propagation delay pales in comparison to the overheads and transmission delay. Remember that time of flight latency owing to switches and other hardware in the network besides sheer propagation delay through the links is neglected in the above example. For noncongested networks, switch latency



generally is small compared to the overheads and propagation delay through the links in WANs and LANs, but this is not necessarily so for multiprocessor SANs and multicore OCNs, as we will see in later sections.

So far, we have considered the transport of a single packet and computed the associated end-to-end total packet latency. In order to compute the effective bandwidth for two networked devices, we have to consider a continuous stream of packets transported between them. We must keep in mind that, in addition to minimizing packet latency, the goal of any network optimized for a given cost and power consumption target is to transfer the maximum amount of available information in the shortest possible time, as measured by the effective bandwidth delivered by the network. For applications that do not require a response before sending the next packet, the sender can overlap the sending overhead of later packets with the transport latency and receiver overhead of prior packets. This essentially pipelines the transmission of packets over the network, also known as *link pipelining*. Fortunately, as discussed in prior chapters of this book, there are many application areas where communication from either several applications or several threads from the same application can run concurrently (e.g., a Web server concurrently serving thousands of client requests or streaming media), thus allowing a device to send a stream of packets without having to wait for an acknowledgment or a reply. Also, as long messages are usually divided into packets of maximum size before transport, a number of packets are injected into the network in succession for such cases. If such overlap were not possible, packets would have to wait for prior packets to be acknowledged before being transmitted and, thus, suffer significant performance degradation.

Packets transported in a pipelined fashion can be acknowledged quite straightforwardly simply by keeping a copy at the source of all unacknowledged packets that have been sent and keeping track of the correspondence between returned acknowledgments and packets stored in the buffer. Packets will be removed from the buffer when the corresponding acknowledgment is received by the sender. This can be done by including the message ID and packet sequence number associated with the packet in the packet's acknowledgment. Furthermore, a separate timer must be associated with each buffered packet, allowing the packet to be resent if the associated time-out expires.

Pipelining packet transport over the network has many similarities with pipelining computation within a processor. However, among some differences are that it does not require any staging latches. Information is simply propagated through network links as a sequence of signal waves. Thus, the network can be considered as a logical pipeline consisting of as many stages as are required so that the time of flight does not affect the effective bandwidth that can be achieved. Transmission of a packet can start immediately after the transmission of the previous one, thus overlapping the sending overhead of a packet with the transport and receiver latency of previous packets. If the sending overhead is smaller than the transmission time, packets follow each other back-to-back, and the effective bandwidth approaches the raw link bandwidth when continuously transmitting packets. On the other hand, if the sending overhead is greater than the transmission time, the effective band-

width at the injection point will remain well below the raw link bandwidth. The resulting *link injection bandwidth*,  $BW_{\text{LinkInjection}}$ , for each link injecting a continuous stream of packets into a network is calculated with the following expression:

$$BW_{\text{LinkInjection}} = \frac{\text{Packet size}}{\max(\text{Sending overhead, Transmission time})}$$

We must also consider what happens if the receiver is unable to consume packets at the same rate they arrive. This occurs if the receiving overhead is greater than the sending overhead and the receiver cannot process incoming packets fast enough. In this case, the *link reception bandwidth*,  $BW_{\text{LinkReception}}$ , for each reception link of the network is less than the link injection bandwidth and is obtained with this expression:

$$BW_{\text{LinkReception}} = \frac{\text{Packet size}}{\max(\text{Receiving overhead, Transmission time})}$$

When communication takes place between two devices interconnected by dedicated links, all the packets sent by one device will be received by the other. If the receiver cannot process packets fast enough, the receiver buffer will become full, and flow control will throttle transmission at the sender. As this situation is produced by causes external to the network, we will not consider it further here. Moreover, if the receiving overhead is greater than the sending overhead, the receiver buffer will fill up and flow control will, likewise, throttle transmission at the sender. In this case, the effect of flow control is, on average, the same as if we replace sending overhead with receiving overhead. Assuming an ideal network that behaves like two dedicated links running in opposite directions at the full link bandwidth between the two devices—which is consistent with our black box view of the network to this point—the resulting effective bandwidth is the smallest among twice the injection bandwidth (to account for the two injection links, one for each device) and twice the reception bandwidth. This results in the following expression for effective bandwidth:

$$\text{Effective bandwidth} = \min(2 \times BW_{\text{LinkInjection}}, 2 \times BW_{\text{LinkReception}}) = \frac{2 \times \text{Packet size}}{\max(\text{Overhead, Transmission time})}$$

where  $\text{Overhead} = \max(\text{Sending overhead, Receiving overhead})$ . Taking into account the expression for the transmission time, it is obvious that the effective bandwidth delivered by the network is identical to the aggregate network bandwidth when the transmission time is greater than the overhead. Therefore, full network utilization is achieved regardless of the value for the time of flight and, thus, regardless of the distance traveled by packets, assuming ideal network behavior (i.e., enough credits and buffers are provided for credit-based and Xon/Xoff flow control). This analysis assumes that the sender and receiver network interfaces can process only one packet at a time. If multiple packets can be processed in parallel (e.g., as is done in IBM's Federation network interfaces), the

overheads for those packets can be overlapped, which increases effective bandwidth by that overlap factor up to the amount bounded by the transmission time.

Let's use the equation on page E-17 to explore the impact of packet size, transmission time, and overhead on  $BW_{\text{Link Injection}}$ ,  $BW_{\text{Link Reception}}$ , and effective bandwidth for the various network domains: OCNs, SANs, LANs, and WANs.

**Example** As in the previous example, assume we have a dedicated link network with a data bandwidth of 8 Gbps for each link in each direction interconnecting the two devices within an OCN, SAN, LAN, or WAN. Plot effective bandwidth versus packet size for each type of network for packets ranging in size from 4 bytes (i.e., a single 32-bit word) to 1500 bytes (i.e., the maximum transfer unit for Ethernet), assuming that end nodes have the same per-packet sending and receiving overheads as before:  $x + 0.05$  ns/byte and  $4/3(x) + 0.05$  ns/byte, respectively, where  $x$  is 0  $\mu$ s for the OCN, 0.3  $\mu$ s for the SAN, 3  $\mu$ s for the LAN, and 30  $\mu$ s for the WAN. What limits the effective bandwidth, and for what packet sizes is the effective bandwidth within 10% of the aggregate network bandwidth?

**Answer** Figure E.6 plots effective bandwidth versus packet size for the four network domains using the simple equation and parameters given above. For all packet sizes in the OCN, transmission time is greater than overhead (sending or receiving), allowing full utilization of the aggregate bandwidth, which is 16 Gbps—that is, injection link (alternatively, reception link) bandwidth times two to account for both devices. For the SAN, overhead—specifically, receiving overhead—is larger than transmission time for packets less than about 800 bytes; consequently, packets of 655 bytes and larger are needed to utilize 90% or more of the aggregate bandwidth. For LANs and WANs, most of the link bandwidth is not utilized since overhead in this example is many times larger than transmission time for all packet sizes.

This example highlights the importance of reducing the sending and receiving overheads relative to packet transmission time in order to maximize the effective bandwidth delivered by the network.

The analysis above suggests that it is possible to provide some upper bound for the effective bandwidth by analyzing the path followed by packets and determining where the bottleneck occurs. We can extend this idea beyond the network interfaces by defining a model that considers the entire network from end to end as a pipe and identifying the narrowest section of that pipe. There are three areas of interest in that pipe: the aggregate of all network injection links and the corresponding *network injection bandwidth* ( $BW_{\text{NetworkInjection}}$ ), the aggregate of all network reception links and the corresponding *network reception bandwidth* ( $BW_{\text{NetworkReception}}$ ), and the aggregate of all network links and the corresponding *network bandwidth* ( $BW_{\text{Network}}$ ). Expressions for these will be given in later sections as various layers of the black box view of the network are peeled away.

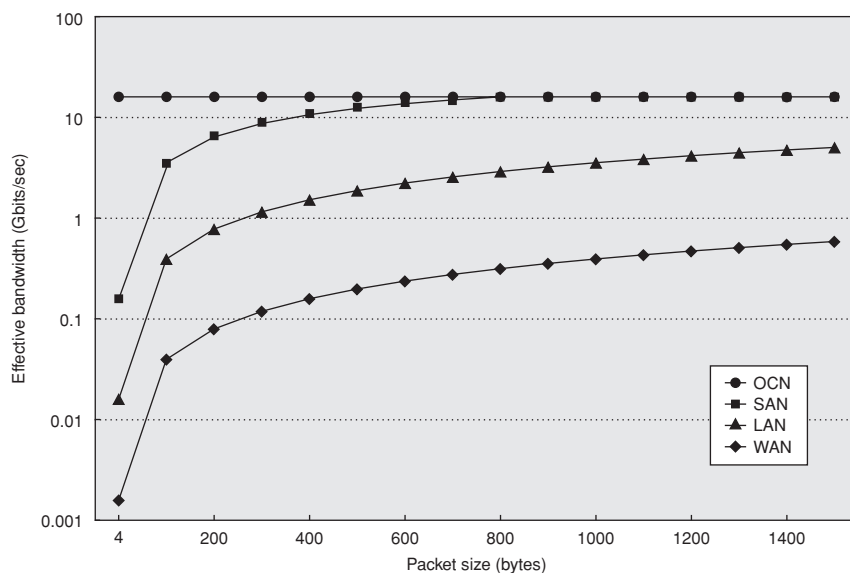

**Figure E.6** Effective bandwidth versus packet size plotted in semi-log form for the four network domains. Overhead can be amortized by increasing the packet size, but for too large of an overhead (e.g., for WANs and some LANs) scaling the packet size is of little help. Other considerations come into play that limit the maximum packet size.

To this point, we have assumed that for just two interconnected devices the black box network behaves ideally and, thus, the network bandwidth is equal to the aggregate raw network bandwidth. In reality, it can be much less than the aggregate bandwidth as we will see in the following sections. In general, the effective bandwidth delivered end-to-end by the network to an application is upper bounded by the minimum across all three potential bottleneck areas:

$$\text{Effective bandwidth} = \min(\text{BW}_{\text{NetworkInjection}}, \text{BW}_{\text{Network}}, \text{BW}_{\text{NetworkReception}})$$

We will expand upon this expression further in the following sections as we reveal more about interconnection networks and consider the more general case of interconnecting more than two devices.

In some sections of this appendix, we show how the concepts introduced in the section take shape in example high-end commercial products. Figure E.7 lists several commercial computers that, at one point in time in their existence, were among the highest-performing systems in the world within their class. Although these systems are capable of interconnecting more than two devices, they implement the basic functions needed for interconnecting only two devices. In addition to being applicable to the SANs used in those systems, the issues discussed in this section also apply to other interconnect domains: from OCNs to WANs.

Company	System [network] name	Intro year	Max. number of compute nodes [× # CPUs]	System footprint for max. configuration	Packet [header] max size (bytes)	Injection [reception] node BW in MB/sec	Minimum send/receive overhead	Maximum copper link length; flow control; error
Intel	ASCI Red Paragon	2001	4510 [× 2]	2500 sq. feet	1984 [4]	400 [400]	few $\mu$ s	handshaking; CRC + parity
IBM	ASCI White SP Power3 [Colony]	2001	512 [× 16]	10,000 sq. feet	1024 [6]	500 [500]	$\sim 3 \mu$ s	25 m; credit-based; CRC
Intel	Thunder Itanium2 Tiger4 [QsNet <sup>II</sup> ]	2004	1024 [× 4]	120 m <sup>2</sup>	2048 [14]	928 [928]	0.240 $\mu$ s	13 m; credit-based; CRC for link, dest.
Cray	XT3 [SeaStar]	2004	30,508 [× 1]	263.8 m <sup>2</sup>	80 [16]	3200 [3200]	few $\mu$ s	7 m; credit-based; CRC
Cray	X1E	2004	1024 [× 1]	27 m <sup>2</sup>	32 [16]	1600 [1600]	0 (direct LD ST accesses)	5 m; credit-based; CRC
IBM	ASC Purple pSeries 575 [Federation]	2005	>1280 [× 8]	6720 sq. feet	2048 [7]	2000 [2000]	$\sim 1 \mu$ s with up to 4 packets processed in	25 m; credit-based; CRC
IBM	Blue Gene/L eServer Sol. [Torus Net.]	2005	65,536 [× 2]	2500 sq. feet (.9 × .9 × 1.9 m <sup>3</sup> /1K node rack)	256 [8]	612.5 [1050]	$\sim 3 \mu$ s (2300 cycles)	8.6 m; credit-based; CRC (header/pkt)

**Figure E.7** Basic characteristics of interconnection networks in commercial high-performance computer systems.

## E.3

### Connecting More than Two Devices

To this point, we have considered the connection of only two devices communicating over a network viewed as a black box, but what makes interconnection networks interesting is the ability to connect hundreds or even many thousands of devices together. Consequently, what makes them interesting also makes them more challenging to build. In order to connect more than two devices, a suitable structure and more functionality must be supported by the network. This section continues with our black box approach by introducing, at a conceptual level, additional network structure and functions that must be supported when interconnecting more than two devices. More details on these individual subjects are given in Sections E.4 through E.7. Where applicable, we relate the additional structure and functions to network media, flow control, and other basics presented in the previous section. In this section, we also classify networks into two

broad categories based on their connection structure—*shared-media* versus *switched-media* networks—and we compare them. Finally, expanded expressions for characterizing network performance are given, followed by an example.

## Additional Network Structure and Functions: Topology, Routing, Arbitration, and Switching

Networks interconnecting more than two devices require mechanisms to physically connect the packet source to its destination in order to transport the packet and deliver it to the correct destination. These mechanisms can be implemented in different ways and significantly vary across interconnection network domains. However, the types of network structure and functions performed by those mechanisms are very much the same, regardless of the domain.

When multiple devices are interconnected by a network, the connections between them oftentimes cannot be permanently established with dedicated links. This could either be too restrictive as all the packets from a given source would go to the same one destination (and not to others) or prohibitively expensive as a dedicated link would be needed from every source to every destination (we will evaluate this further in the next section). Therefore, networks usually share paths among different pairs of devices, but how those paths are shared is determined by the network connection structure, commonly referred to as the network *topology*. Topology addresses the important issue of “*What paths are possible for packets?*” in order for packets to reach their intended destination.

Every network that interconnects more than two devices also requires some mechanism to deliver each packet to the correct destination. The associated function is referred to as *routing*, which can be defined as the set of operations that need to be performed to compute a valid path from the packet source to its destination. Routing addresses the important issue of “*Which of the possible paths are allowable (valid) for packets?*” in order for packets to reach their intended destination. Depending on the network, this function may be executed at the packet source to compute the entire path, at some intermediate devices to compute fragments of the path on-the-fly, or even at every possible destination device to verify whether that device is the intended destination for the packet. Usually the packet header shown in Figure E.4 is extended to include the necessary routing information.

In general, as networks usually contain shared paths or parts thereof among different pairs of devices, packets may request some shared resources. When several packets request the same resources at the same time, an *arbitration* function is required to resolve the conflict. Arbitration, along with flow control, addresses the important issue of “*When are paths available for packets?*” Every time arbitration is performed, there is a winner and, possibly, several losers. The losers are not granted access to the requested resources and are typically buffered. As indicated in the previous section, flow control may be implemented to prevent buffer overflow. The winner proceeds toward its destination once the granted resources are switched in, providing a path for the packet to advance. This function is

referred to as *switching*. Switching addresses the important issue of “*How are paths allocated to packets?*” To achieve better utilization of existing communication resources, most networks do not establish an entire end-to-end path at once. Instead, as explained in Section E.5, paths are usually established one fragment at a time.

These three network functions—routing, arbitration, and switching—must be implemented in every network connecting more than two devices, no matter what form the network topology takes. This is in addition to the basic functions mentioned in the previous section. However, the complexity of these functions and the order in which they are performed depends on the category of network topology, as discussed below. In general, routing, arbitration, and switching are required to establish a valid path from source to destination from among the possible paths provided by the network topology. Once the path has been established, the packet transport functions previously described are used to reliably transmit packets and receive them at the corresponding destination. Flow control, if implemented, prevents buffer overflow by throttling the sender. It can be implemented at the end-to-end level, the link-level within the network, or both.

## Shared-Media Networks

The simplest way to connect multiple devices is to have them share the network media, as shown for the bus in Figure E.8 (a). This has been the traditional way of interconnecting devices. The shared media can operate in *half-duplex* mode, where data can be carried in either direction over the media but simultaneous transmission and reception of data by the same device is not allowed, or in *full-duplex*, where the data can be carried in both directions and simultaneously transmitted and received by the same device. Until very recently, I/O devices in most

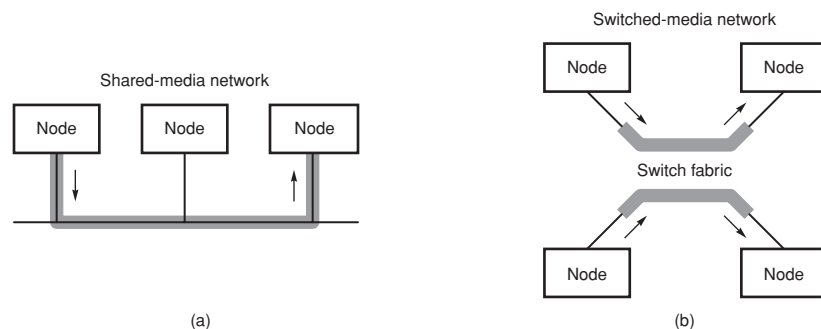

**Figure E.8** (a) A shared-media network versus (b) a switched-media network. Ethernet was originally a shared media network, but switched Ethernet is now available. All nodes on the shared-media must dynamically share the raw bandwidth of one link, but switched-media networks can support multiple links, providing higher raw aggregate bandwidth.



systems typically shared a single I/O bus, and early system-on-chip (SoC) designs made use of a shared bus to interconnect on-chip components. The most popular LAN, Ethernet, was originally implemented as a half-duplex bus shared by up to a hundred computers, although now switched-media versions also exist.

Given that network media are shared, there must be a mechanism to coordinate and arbitrate the use of the shared media so that only one packet is sent at a time. If the physical distance between network devices is small, it may be possible to have a central arbiter to grant permission to send packets. In this case, the network nodes may use dedicated control lines to interface with the arbiter. Centralized arbitration is impractical, however, for networks with a large number of nodes spread over large distances, so distributed forms of arbitration are also used. This is the case for the original Ethernet shared-media LAN.

A first step toward distributed arbitration of shared media is “looking before you leap.” A node first checks the network to avoid trying to send a packet while another packet is already in the network. Listening before transmission to avoid collisions is called *carrier sensing*. If the interconnection is idle, the node tries to send. Looking first is not a guarantee of success, of course, as some other node may also decide to send at the same instant. When two nodes send at the same time, a *collision* occurs. Let’s assume that the network interface can detect any resulting collisions by listening to hear if the data becomes garbled by other data appearing on the line. Listening to detect collisions is called *collision detection*. This is the second step of distributed arbitration.

The problem is not solved yet. If, after detecting a collision, every node on the network waited exactly the same amount of time, listened to be sure there was no traffic, and then tried to send again, we could still have synchronized nodes that would repeatedly bump heads. To avoid repeated head-on collisions, each node whose packet gets garbled waits (or *backs off*) a random amount of time before resending. Randomization breaks the synchronization. Subsequent collisions result in exponentially increasing time between attempts to retransmit, so as not to tax the network.

Although this approach controls congestion on the shared media, it is not guaranteed to be fair—some subsequent node may transmit while those that collided are waiting. If the network does not have high demand from many nodes, this simple approach works well. Under high utilization, however, performance degrades since the media are shared and fairness is not ensured. Another distributed approach to arbitration of shared media that can support fairness is to pass a token between nodes. The function of the token is to grant the acquiring node the right to use the network. If the token circulates in a cyclic fashion between the nodes, a certain amount of fairness is ensured in the arbitration process.

Once arbitration has been performed and a device has been granted access to the shared media, the function of switching is straightforward. The granted device simply needs to connect itself to the shared media, thus establishing a path to every possible destination. Also, routing is very simple to implement. Given that the media are shared and attached to all the devices, every device will see every packet. Therefore, each device just needs to check whether or not a given



packet is intended for that device. A beneficial side effect of this strategy is that a device can send a packet to all the devices attached to the shared media through a single transmission. This style of communication is called *broadcasting*, in contrast to *unicasting*, in which each packet is intended for only one device. The shared media make it easy to broadcast a packet to every device or, alternatively, to a subset of devices, called *multicasting*.

## Switched-Media Networks

The alternative to sharing the entire network media at once across all attached nodes is to switch between disjoint portions of it shared by the nodes. Those portions consist of passive *point-to-point links* between active *switch* components that dynamically establish communication between sets of source-destination pairs. These passive and active components make up what is referred to as the network *switch fabric* or *network fabric*, to which end nodes are connected. This approach is shown conceptually in Figure E.8 (b). The switch fabric is described in greater detail in Sections E.4 through E.7, where various black box layers for switched-media networks are further revealed. Nevertheless, the high-level view shown in Figure E.8 (b) illustrates the potential bandwidth improvement of switched-media networks over shared-media networks: aggregate bandwidth can be many times higher than that of shared-media networks, allowing the possibility of greater effective bandwidth to be achieved. At best, only one node at a time can transmit packets over the shared media, whereas it is possible for all attached nodes to do so over the switched-media network.

Like their shared-media counterparts, switched-media networks must implement the three additional functions previously mentioned: routing, arbitration, and switching. Every time a packet enters the network, it is routed in order to select a path toward its destination provided by the topology. The path requested by the packet must be granted by some centralized or distributed arbiter, which resolves conflicts among concurrent requests for resources along the same path. Once the requested resources are granted, the network “switches in” the required connections to establish the path and allow the packet to be forwarded toward its destination. If the requested resources are not granted, the packet is usually buffered, as mentioned previously. Routing, arbitration, and switching functions are usually performed within switched networks in this order, whereas in shared-media networks routing typically is the last function performed.

## Comparison of Shared- and Switched-Media Networks

In general, the advantage of shared-media networks is their low cost, but, consequently, their aggregate network bandwidth does not scale at all with the number of interconnected devices. Also, a global arbitration scheme is required to resolve conflicting demands, possibly introducing another type of bottleneck and again limiting scalability. Moreover, every device attached to the shared media increases the parasitic capacitance of the electrical conductors, thus increasing

the time of flight propagation delay accordingly and, possibly, clock cycle time. In addition, it is more difficult to pipeline packet transmission over the network as the shared media are continuously granted to different requesting devices.

The main advantage of switched-media networks is that the amount of network resources implemented scales with the number of connected devices, increasing the aggregate network bandwidth. These networks allow multiple pairs of nodes to communicate simultaneously, allowing much higher effective network bandwidth than that provided by shared-media networks. Also, switched-media networks allow the system to scale to very large numbers of nodes, which is not feasible when using shared media. Consequently, this scaling advantage can, at the same time, be a disadvantage if network resources grow superlinearly. Networks of superlinear cost that provide an effective network bandwidth that grows only sublinearly with the number of interconnected devices are inefficient designs for many applications and interconnection network domains.

### Characterizing Performance: Latency and Effective Bandwidth

The routing, switching, and arbitration functionality described above introduces some additional components of packet transport latency that must be taken into account in the expression for total packet latency. Assuming there is no contention for network resources—as would be the case in an unloaded network—total packet latency is given by the following:

$$\text{Latency} = \text{Sending overhead} + (T_{\text{TotalProp}} + T_{\text{R}} + T_{\text{A}} + T_{\text{S}}) + \frac{\text{Packet size}}{\text{Bandwidth}} + \text{Receiving overhead}$$

Here  $T_{\text{R}}$ ,  $T_{\text{A}}$ , and  $T_{\text{S}}$  are the total routing time, arbitration time, and switching time experienced by the packet, respectively, and are either measured quantities or calculated quantities derived from more detailed analyses. These components are added to the total propagation delay through the network links,  $T_{\text{TotalProp}}$ , to give the overall time of flight of the packet.

The expression above gives only a lower bound for the total packet latency as it does not account for additional delays due to contention for resources that may occur. When the network is heavily loaded, several packets may request the same network resources concurrently, thus causing contention that degrades performance. Packets that lose arbitration have to be buffered, which increases packet latency by some *contention delay* amount of waiting time. This additional delay is not included in the above expression. When the network or part of it approaches saturation, contention delay may be several orders of magnitude greater than the total packet latency suffered by a packet under zero load or even under slightly loaded network conditions. Unfortunately, it is not easy to compute analytically the total packet latency when the network is more than moderately loaded. Measurement of these quantities using cycle-accurate simulation of a detailed network model is a better and more precise way of estimating packet latency under such circumstances. Nevertheless, the expression given above is useful in calculating *best-case lower bounds* for packet latency.

For similar reasons, effective bandwidth is not easy to compute exactly, but we can estimate *best-case upper bounds* for it by appropriately extending the model presented at the end of the previous section. What we need to do is to find the narrowest section of the end-to-end network pipe by finding the network injection bandwidth ( $BW_{\text{NetworkInjection}}$ ), the network reception bandwidth ( $BW_{\text{NetworkReception}}$ ), and the network bandwidth ( $BW_{\text{Network}}$ ) across the entire network interconnecting the devices.

The  $BW_{\text{NetworkInjection}}$  can be calculated simply by multiplying the expression for link injection bandwidth,  $BW_{\text{LinkInjection}}$ , by the total number of network injection links. The  $BW_{\text{NetworkReception}}$  is calculated similarly using  $BW_{\text{LinkReception}}$ , but it must also be scaled by a factor that reflects application traffic and other characteristics. For more than two interconnected devices, it is no longer valid to assume a one-to-one relationship among sources and destinations when analyzing the effect of flow control on link reception bandwidth. It could happen, for example, that several packets from different injection links arrive concurrently at the same reception link for applications that have many-to-one traffic characteristics, which causes contention at the reception links. This effect can be taken into account by an *average reception factor* parameter,  $\sigma$ , which is either a measured quantity or a calculated quantity derived from detailed analysis. It is defined as the average fraction or percentage of packets arriving at reception links that can be accepted. Only those packets can be immediately delivered, thus reducing network reception bandwidth by that factor. This reduction occurs as a result of application behavior regardless of internal network characteristics. Finally,  $BW_{\text{Network}}$  takes into account the internal characteristics of the network, including contention. We will progressively derive expressions in the following sections that will enable us to calculate this as more details are revealed about the internals of our black box interconnection network.

Overall, the effective bandwidth delivered by the network end-to-end to an application is determined by the minimum across the three sections, as described by the following:

$$\begin{aligned} \text{Effective bandwidth} &= \min(BW_{\text{NetworkInjection}}, BW_{\text{Network}}, \sigma \times BW_{\text{NetworkReception}}) \\ &= \min(N \times BW_{\text{LinkInjection}}, BW_{\text{Network}}, \sigma \times N \times BW_{\text{LinkReception}}) \end{aligned}$$

Let's use the above expressions to compare the latency and effective bandwidth of shared-media networks against switched-media networks for the four interconnection network domains: OCNs, SANs, LANs, and WANs.

---

**Example** Plot the total packet latency and effective bandwidth as the number of interconnected nodes,  $N$ , scales from 4 to 1024 for shared-media and switched-media OCNs, SANs, LANs, and WANs. Assume that all network links, including the injection and reception links at the nodes, each have a data bandwidth of 8 Gbps, and unicast packets of 100 bytes are transmitted. Shared-media networks share one link, and switched-media networks have at least as many network links as

there are nodes. For both, ignore latency and bandwidth effects due to contention within the network. End nodes have per-packet sending and receiving overheads of  $x + 0.05$  ns/byte and  $4/3(x) + 0.05$  ns/byte, respectively, where  $x$  is  $0 \mu\text{s}$  for the OCN,  $0.3 \mu\text{s}$  for the SAN,  $3 \mu\text{s}$  for the LAN, and  $30 \mu\text{s}$  for the WAN, and inter-connection distances are 0.5 cm, 5 m, 5000 m, and 5000 km, respectively. Also assume that the total routing, arbitration, and switching times are constants or functions of the number of interconnected nodes:  $T_R = 2.5$  ns,  $T_A = 2.5(N)$  ns, and  $T_S = 2.5$  ns for shared-media networks and  $T_R = T_A = T_S = 2.5(\log_2 N)$  ns for switched-media networks. Finally, taking into account application traffic characteristics for the network structure, the average reception factor,  $\sigma$ , is assumed to be  $N^{-1}$  for shared media and polylogarithmic  $(\log_2 N)^{-1/4}$  for switched media.

**Answer** All components of total packet latency are the same as in the example given in the previous section except for time of flight, which now has additional routing, arbitration, and switching delays. For shared-media networks, the additional delays total  $5 + 2.5(N)$  ns; for switched-media networks, they total  $7.5(\log_2 N)$  ns. Latency is plotted only for OCNs and SANs in Figure E.9 as these networks give the more interesting results. For OCNs,  $T_R$ ,  $T_A$ , and  $T_S$  combine to dominate time of flight and are much greater than each of the other latency components for a moderate to large number of nodes. This is particularly so for the shared-media

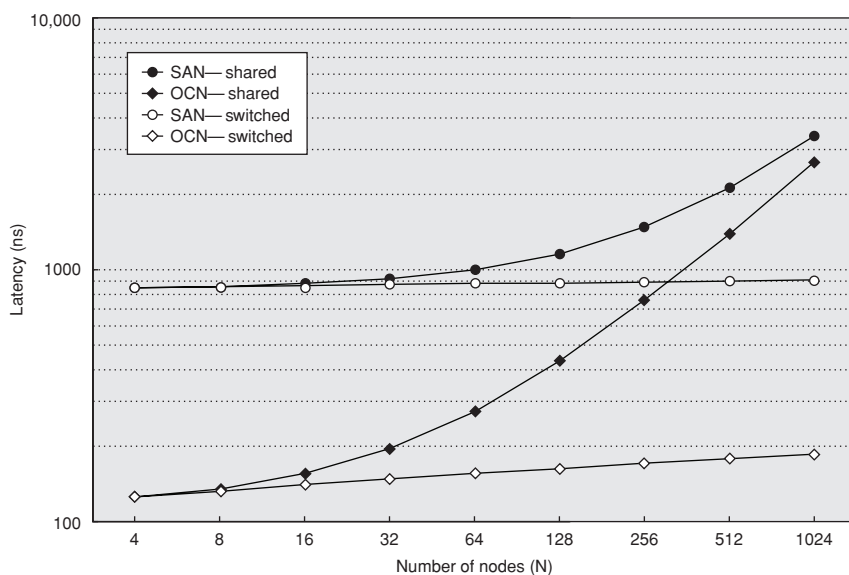

**Figure E.9** Latency versus number of interconnected nodes plotted in semi-log form for OCNs and SANs. Routing, arbitration, and switching have more of an impact on latency for networks in these two domains, particularly for networks with a large number of nodes, given the low sending and receiving overheads and low propagation delay.

network. The latency increases much more dramatically with the number of nodes for shared media as compared to switched media given the difference in arbitration delay between the two. For SANs,  $T_R$ ,  $T_A$ , and  $T_S$  dominate time of flight for most network sizes but are greater than each of the other latency components in shared-media networks only for large-sized networks; they are less than the other latency components for switched-media networks but are not negligible. For LANs and WANs, time of flight is dominated by propagation delay, which dominates other latency components as calculated in the previous section; thus,  $T_R$ ,  $T_A$ , and  $T_S$  are negligible for both shared and switched media.

Figure E.10 plots effective bandwidth versus number of interconnected nodes for the four network domains. The effective bandwidth for all shared-media networks is constant through network scaling as only one unicast packet can be received at a time over all the network reception links, and that is further limited by the receiving overhead of each network for all but the OCN. The effective bandwidth for all switched-media networks increases with the number of inter-connected nodes, but it is scaled down by the average reception factor. The receiving overhead further limits effective bandwidth for all but the OCN.

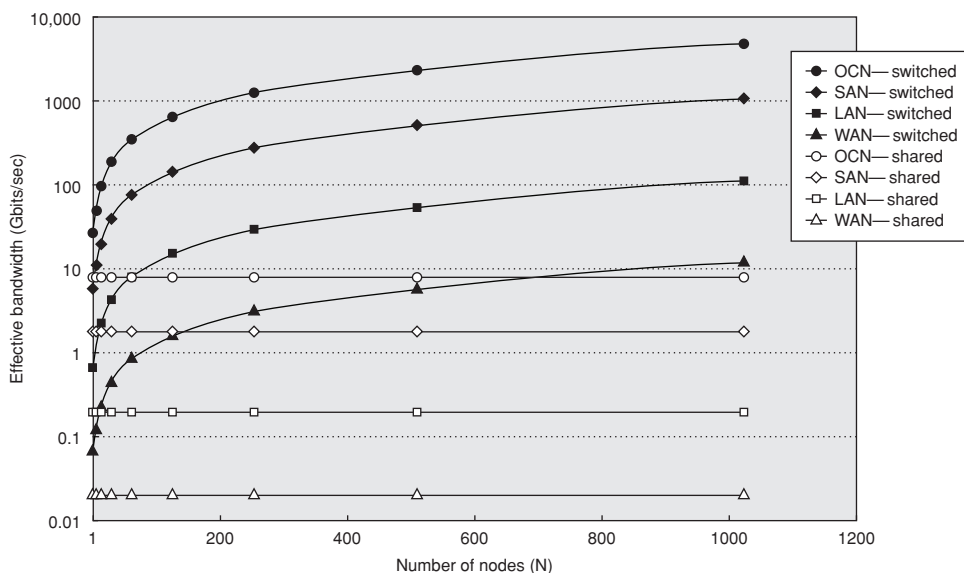

**Figure E.10** Effective bandwidth versus number of interconnected nodes plotted in semi-log form for the four network domains. The disparity in effective bandwidth between shared- and switched-media networks for all interconnect domains widens significantly as the number of nodes in the network increases. Only the switched on-chip network is able to achieve an effective bandwidth equal to the aggregate bandwidth for the parameters given in this example.

Given the obvious advantages, why weren't switched networks always used? Earlier computers were much slower and could share the network media with little impact on performance. In addition, the switches for earlier LANs and WANs took up several large boards and were about as large as an entire computer. As a consequence of Moore's Law, the size of switches has reduced considerably, and systems have a much greater need for high-performance communication. Switched networks allow communication to harvest the same rapid advancements from silicon as processors and main memory. Whereas switches from telecommunication companies were once the size of mainframe computers, today we see single-chip switches and even entire switched networks within a chip. Thus, technology and application trends favor switched networks today. Just as single-chip processors led to processors replacing logic circuits in a surprising number of places, single-chip switches and switched on-chip networks are increasingly replacing shared-media networks (i.e., buses) in several application domains. As an example, PCI-Express (PCIe)—a switched network—was introduced in 2005 to replace the traditional PCI-X bus on personal computer motherboards.

The previous example also highlights the importance of optimizing the routing, arbitration, and switching functions in OCNs and SANs. For these network domains in particular, the interconnect distances and overheads typically are small enough to make latency and effective bandwidth much more sensitive to how well these functions are implemented, particularly for larger-sized networks. This leads mostly to implementations based mainly on the faster hardware solutions for these domains. In LANs and WANs, implementations based on the slower but more flexible software solutions suffice given that performance is largely determined by other factors. The design of the topology for switched-media networks also plays a major role in determining how close to the lower bound on latency and the upper bound on effective bandwidth the network can achieve for OCN and SAN domains.

The next three sections touch on these important issues in switched networks, with the next section focused on topology.

---

## E.4

## Network Topology

When the number of devices is small enough, a single switch is sufficient to interconnect them within a switched-media network. However, the number of *switch ports* is limited by existing VLSI technology, cost considerations, power consumption, and so on. When the number of required *network ports* exceeds the number of ports supported by a single switch, a fabric of interconnected switches is needed. To embody the necessary property of *full access* (i.e., *connectedness*), the network switch fabric must provide a path from every end node device to every other device. All the connections to the network fabric and between switches within the fabric use point-to-point links as opposed to shared links—that is, links with only one switch or end node device on either end. The interconnection structure across all the components—including switches, links, and end node devices—is referred to as the network *topology*.

The number of network topologies described in the literature would be difficult to count, but the number that have been used commercially is no more than about a dozen or so. During the 1970s and early 1980s, researchers struggled to propose new topologies that could reduce the number of switches through which packets must traverse, referred to as the *hop count*. In the 1990s, thanks to the introduction of pipelined transmission and switching techniques, the hop count became less critical. Nevertheless, today, topology is still important, particularly for OCNs and SANs, as subtle relationships exist between topology and other network design parameters that impact performance, especially when the number of end nodes is very large (e.g., 64K in the Blue Gene/L supercomputer) or when the latency is critical (e.g., in multicore processor chips). Topology also greatly impacts the implementation cost of the network.

Topologies for parallel supercomputer SANs have been the most visible and imaginative, usually converging on regularly structured ones to simplify routing, packaging, and scalability. Those for LANs and WANs tend to be more haphazard or ad hoc, having more to do with the challenges of long distance or connecting across different communication subnets. Switch-based topologies for OCNs are only recently emerging but are quickly gaining in popularity. This section describes the more popular topologies used in commercial products. Their advantages, disadvantages, and constraints are also briefly discussed.

## Centralized Switched Networks

As mentioned above, a single switch suffices to interconnect a set of devices when the number of switch ports is equal to or larger than the number of devices. This simple network is usually referred to as a *crossbar* or *crossbar switch*. Within the crossbar, crosspoint switch complexity increases quadratically with the number of ports, as illustrated in Figure E.11 (a). Thus, a cheaper solution is desirable when the number of devices to be interconnected scales beyond the point supportable by implementation technology.

A common way of addressing the crossbar scaling problem consists of splitting the large crossbar switch into several stages of smaller switches interconnected in such a way that a single pass through the switch fabric allows any destination to be reached from any source. Topologies arranged in this way are usually referred to as *multistage interconnection networks* or *multistage switch fabrics*, and these networks typically have complexity that increases in proportion to  $N \log N$ . Multistage interconnection networks (MINs) were initially proposed for telephone exchanges in the 1950s and have since been used to build the communication backbone for parallel supercomputers, symmetric multiprocessors, multicomputer clusters, and IP router switch fabrics.

The interconnection pattern or patterns between MIN stages are permutations that can be represented mathematically by a set of functions, one for each stage. Figure E.11 (b) shows a well-known MIN topology, the *Omega*, which uses the perfect-shuffle permutation as its interconnection pattern for each stage, followed by exchange switches, giving rise to a *perfect-shuffle exchange* for each stage. In



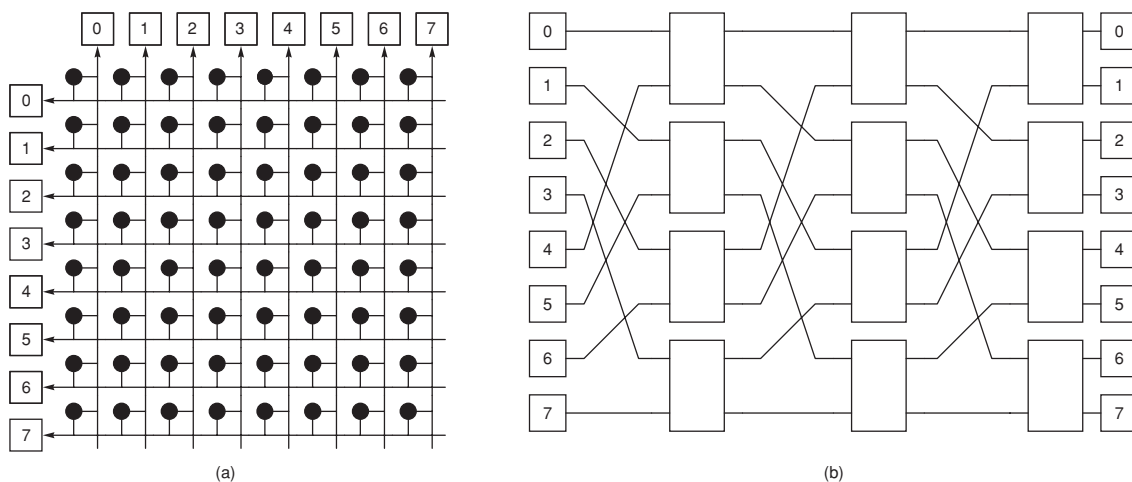

**Figure E.11** Popular centralized switched networks: (a) the crossbar network requires  $N^2$  crosspoint switches, shown as black dots; (b) the Omega, a MIN, requires  $N/2 \log_2 N$  switches, shown as vertical rectangles. End node devices are shown as numbered squares (total of eight). Links are unidirectional—data enter at the left and exit out the top or right.

this example, eight input-output ports are interconnected with three stages of  $2 \times 2$  switches. It is easy to see that a single pass through the three stages allows any input port to reach any output port. In general, when using  $k \times k$  switches, a MIN with  $N$  input-output ports requires at least  $\log_k N$  stages, each of which contains  $N/k$  switches, for a total of  $N/k (\log_k N)$  switches.

Despite their internal structure, MINs can be seen as centralized switch fabrics that have end node devices connected at the network periphery, hence the name *centralized switched network*. From another perspective, MINs can be viewed as interconnecting nodes through a set of switches that may not have any nodes directly connected to them, which gives rise to another popular name for centralized switched networks—*indirect networks*.

---

**Example** Compute the cost of interconnecting 4096 nodes using a single crossbar switch relative to doing so using a MIN built from  $2 \times 2$ ,  $4 \times 4$ , and  $16 \times 16$  switches. Consider separately the relative cost of the unidirectional links and the relative cost of the switches. Switch cost is assumed to grow quadratically with the number of input (alternatively, output) ports,  $k$ , for  $k \times k$  switches.

**Answer** The switch cost of the network when using a single crossbar is proportional to  $4096^2$ . The unidirectional link cost is 8192, which accounts for the set of links from the end nodes to the crossbar and also from the crossbar back to the end nodes. When using a MIN with  $k \times k$  switches, the cost of each switch is proportional to  $k^2$  but there are  $4096/k (\log_k 4096)$  total switches. Likewise, there are



$(\log_k 4096)$  stages of  $N$  unidirectional links per stage from the switches plus  $N$  links to the MIN from the end nodes. Therefore, the relative costs of the crossbar with respect to each MIN is given by the following:

$$\text{Relative cost } (2 \times 2)_{\text{switches}} = 4096^2 / (2^2 \times 4096/2 \times \log_2 4096) = 170$$

$$\text{Relative cost } (4 \times 4)_{\text{switches}} = 4096^2 / (4^2 \times 4096/4 \times \log_4 4096) = 170$$

$$\text{Relative cost } (16 \times 16)_{\text{switches}} = 4096^2 / (16^2 \times 4096/16 \times \log_{16} 4096) = 85$$

$$\text{Relative cost } (2 \times 2)_{\text{links}} = 8192 / (4096 \times (\log_2 4096 + 1)) = 2/13 = 0.1538$$

$$\text{Relative cost } (4 \times 4)_{\text{links}} = 8192 / (4096 \times (\log_4 4096 + 1)) = 2/7 = 0.2857$$

$$\text{Relative cost } (16 \times 16)_{\text{links}} = 8192 / (4096 \times (\log_{16} 4096 + 1)) = 2/4 = 0.5$$

In all cases, the single crossbar has much higher switch cost than the MINs. The most dramatic reduction in cost comes from the MIN composed from the smallest sized but largest number of switches, but it is interesting to see that the MINs with  $2 \times 2$  and  $4 \times 4$  switches yield the same relative switch cost. The relative link cost of the crossbar is lower than the MINs, but by less than an order of magnitude in all cases. We must keep in mind that end node links are different from switch links in their length and packaging requirements, so they usually have different associated costs. Despite the lower link cost, the crossbar has higher overall relative cost.

---

The reduction in switch cost of MINs comes at the price of performance: contention is more likely to occur on network links, thus degrading performance. Contention in the form of packets *blocking* in the network arises due to paths from different sources to different destinations simultaneously sharing one or more links. The amount of contention in the network depends on communication traffic behavior. In the Omega network shown in Figure E.11 (b), for example, a packet from port 0 to port 1 blocks in the first stage of switches while waiting for a packet from port 4 to port 0. In the crossbar, no such blocking occurs as links are not shared among paths to unique destinations. The crossbar, therefore, is *nonblocking*. Of course, if two nodes try to send packets to the same destination, there will be blocking at the reception link even for crossbar networks. This is accounted for by the average reception factor parameter ( $\sigma$ ) when analyzing performance, as discussed at the end of the previous section.

To reduce blocking in MINs, extra switches must be added or larger ones need to be used to provide alternative paths from every source to every destination. The first commonly used solution is to add a minimum of  $\log_k N - 1$  extra switch stages to the MIN in such a way that they mirror the original topology. The resulting network is *rearrangeably nonblocking* as it allows nonconflicting paths among new source-destination pairs to be established, but it also doubles the hop count and could require the paths of some existing communicating pairs to be rearranged under some centralized control. The second solution takes a different approach. Instead of using more switch stages, larger switches—which can

be implemented by multiple stages if desired—are used in the middle of two other switch stages in such a way that enough alternative paths through the middle-stage switches allow for nonconflicting paths to be established between the first and last stages. The best-known example of this is the Clos network, which is nonblocking. The multipath property of the three-stage Clos topology can be recursively applied to the middle-stage switches to reduce the size of all the switches down to  $2 \times 2$ , assuming that switches of this size are used in the first and last stages to begin with. What results is a Beneš topology consisting of  $2(\log_2 N) - 1$  stages, which is rearrangeably nonblocking. Figure E.12 (a) illustrates both topologies, where all switches not in the first and last stages comprise the middle-stage switches (recursively) of the Clos network.

The MINs described so far have unidirectional network links, but bidirectional forms are easily derived from symmetric networks such as the Clos and Beneš simply by folding them. The overlapping unidirectional links run in different directions, thus forming bidirectional links, and the overlapping switches merge into a single switch with twice the ports (i.e.,  $4 \times 4$  switch). Figure E.12 (b) shows the resulting folded Beneš topology but in this case with the end nodes connected to the innermost switch stage of the original Beneš. Ports remain free at the other side of the network but can be used for later expansion of the network to larger sizes. These kind of networks are referred to as *bidirectional multistage interconnection networks*. Among many useful properties of these networks are their modularity and their ability to exploit communication locality, which saves packets from having to hop across all network stages. Their regularity also

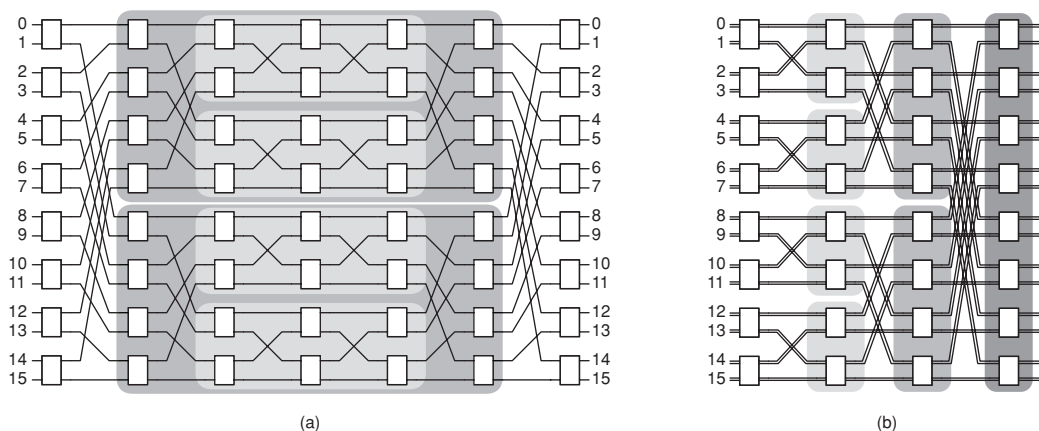

**Figure E.12** Two Beneš networks. (a) A 16-port Clos topology, where the middle-stage switches shown in the darker shading are implemented with another Clos network whose middle-stage switches shown in the lighter shading are implemented with yet another Clos network, and so on, until a Beneš network is produced that uses only  $2 \times 2$  switches everywhere. (b) A folded Beneš network (bidirectional) in which  $4 \times 4$  switches are used; end nodes attach to the innermost set of the Beneš network (unidirectional) switches. This topology is equivalent to a fat tree, where tree vertices are shown in shades.

reduces routing complexity and their multipath property enables traffic to be routed more evenly across network resources and to tolerate faults.

Another way of deriving bidirectional MINs with nonblocking (rearrangeable) properties is to form a balanced tree, where end node devices occupy leaves of the tree and switches occupy vertices within the tree. Enough links in each tree level must be provided such that the total link bandwidth remains constant across all levels. Also, except for the root, switch ports for each vertex typically grow as  $k^i \times k^i$ , where  $i$  is the tree level. This can be accomplished by using  $k^{i-1}$  total switches at each vertex, where each switch has  $k$  input and  $k$  output ports, or  $k$  bidirectional ports (i.e.,  $k \times k$  input-output ports). Networks having such topologies are called *fat tree* networks. As only half of the  $k$  bidirectional ports are used in each direction,  $2N/k$  switches are needed in each stage, totaling  $2N/k (\log_{k/2} N)$  switches in the fat tree. The number of switches in the root stage can be halved as no forward links are needed, reducing switch count by  $N/k$ . Figure E.12 (b) shows a fat tree for  $4 \times 4$  switches. As can be seen, this is identical to the folded Beneš.

The fat tree is the topology of choice across a wide range of network sizes for most commercial systems that use multistage interconnection networks. Most SANs used in multicomputer clusters and many used in the most powerful supercomputers are based on fat trees. Commercial communication subsystems offered by Myrinet, Mellanox, and Quadrics are also built from fat trees.

## Distributed Switched Networks

Switched-media networks provide a very flexible framework to design communication subsystems external to the devices that need to communicate, as presented above. However, there are cases where it is convenient to more tightly integrate the end node devices with the network resources used to enable them to communicate. Instead of centralizing the switch fabric in an external subsystem, an alternative approach is to distribute the network switches among the end nodes, which then become *network nodes* or simply *nodes*, yielding a *distributed switched network*. As a consequence, each network switch has one or more end node devices directly connected to it, thus forming a network node. These nodes are directly connected to other nodes without indirectly going through some external switch, giving rise to another popular name for these networks—*direct networks*.

The topology for distributed switched networks takes on a form much different from centralized switched networks in that end nodes are connected across the area of the switch fabric, not just at one or two of the peripheral edges of the fabric. This causes the number of switches in the system to be equal to the total number of nodes. A quite obvious way of interconnecting nodes consists of connecting a dedicated link between each node and every other node in the network. This *fully connected* topology provides the best connectivity (full connectivity in fact), but it is more costly than a crossbar network, as the following example shows.

**Example** Compute the cost of interconnecting  $N$  nodes using a fully connected topology relative to doing so using a crossbar topology. Consider separately the relative cost of the unidirectional links and the relative cost of the switches. Switch cost is assumed to grow quadratically with the number of unidirectional ports for  $k \times k$  switches but to grow only linearly with  $1 \times k$  switches.

**Answer** The crossbar topology requires an  $N \times N$  switch, so the switch cost is proportional to  $N^2$ . The link cost is  $2N$ , which accounts for the unidirectional links from the end nodes to the centralized crossbar, and vice versa. In the fully connected topology, two sets of  $1 \times (N - 1)$  switches (possibly merged into one set) are used in each of the  $N$  nodes to connect nodes directly to and from all other nodes. Thus, the total switch cost for all  $N$  nodes is proportional to  $2N(N - 1)$ . Regarding link cost, each of the  $N$  nodes requires two unidirectional links in opposite directions between its end node device and its local switch. In addition, each of the  $N$  nodes has  $N - 1$  unidirectional links from its local switch to other switches distributed across all the other end nodes. Thus, the total number of unidirectional links is  $2N + N(N - 1)$ , which is equal to  $N(N + 1)$  for all  $N$  nodes. The relative costs of the fully connected topology with respect to the crossbar is, therefore, the following:

$$\text{Relative cost}_{\text{switches}} = 2N(N - 1) / N^2 = 2(N - 1) / N = 2(1 - 1/N)$$

$$\text{Relative cost}_{\text{links}} = N(N + 1) / 2N = (N + 1)/2$$

As the number of interconnected devices increases, the switch cost of the fully connected topology is nearly double the crossbar, with both being very high (i.e., quadratic growth). Moreover, the fully connected topology always has higher relative link cost, which grows linearly with the number of nodes. Again, keep in mind that end node links are different from switch links in their length and packaging, particularly for direct networks, so they usually have different associated costs. Despite its higher cost, the fully connected topology provides no extra performance benefits over the crossbar as both are nonblocking. Thus, crossbar networks are usually used in practice instead of fully connected networks.

A lower-cost alternative to fully connecting all nodes in the network is to directly connect nodes in sequence along a *ring* topology, as shown in Figure E.13. For bidirectional rings, each of the  $N$  nodes now uses only  $3 \times 3$  switches and just two bidirectional network links (shared by neighboring nodes), for a total of  $N$  switches and  $N$  bidirectional network links. This linear cost excludes the  $N$  injection-reception bidirectional links required within nodes.

Unlike shared-media networks, rings can allow many simultaneous transfers: the first node can send to the second while the second sends to the third, and so on. However, as dedicated links do not exist between logically nonadjacent node pairs, packets must hop across intermediate nodes before arriving at their destination, increasing their transport latency. For bidirectional rings, packets can be

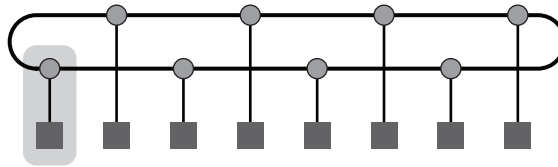

**Figure E.13** A ring network topology, folded to reduce the length of the longest link. Shaded circles represent switches, and black squares represent end node devices. The gray rectangle signifies a network node consisting of a switch, a device, and its connecting link.

transported in either direction, with the shortest path to the destination usually being the one selected. In this case, packets must travel  $N/4$  network switch hops, on average, with total switch hop count being one more to account for the local switch at the packet source node. Along the way, packets may block on network resources due to other packets contending for the same resources simultaneously.

Fully connected and ring connected networks delimit the two extremes of distributed switched topologies, but there are many points of interest in between for a given set of cost-performance requirements. Generally speaking, the ideal switched-media topology has cost approaching that of a ring but performance approaching that of a fully connected topology. Figure E.14 illustrates three popular direct network topologies commonly used in systems spanning the cost-performance spectrum. All of them consist of sets of nodes arranged along multiple dimensions with a regular interconnection pattern among nodes that can be expressed mathematically. In the *mesh* or *grid* topology, all the nodes in each dimension form a linear array. In the *torus* topology, all the nodes in each dimension form a ring. Both of these topologies provide direct communication to neighboring nodes with the aim of reducing the number of hops suffered by packets in the network with respect to the ring. This is achieved by providing greater connectivity through additional dimensions, typically no more than three in commercial systems. The *hypercube* or *n-cube* topology is a particular case of the mesh in which only two nodes are interconnected along each dimension, leading to a number of dimensions,  $n$ , that must be large enough to interconnect all  $N$  nodes in the system (i.e.,  $n = \log_2 N$ ). The hypercube provides better connectivity than meshes and tori at the expense of higher link and switch costs, in terms of the number of links and number of ports per node.

---

**Example** Compute the cost of interconnecting  $N$  devices using a torus topology relative to doing so using a fat tree topology. Consider separately the relative cost of the bidirectional links and the relative cost of the switches—which is assumed to grow quadratically with the number of bidirectional ports. Provide an approximate expression for the case of switches being similar in size.

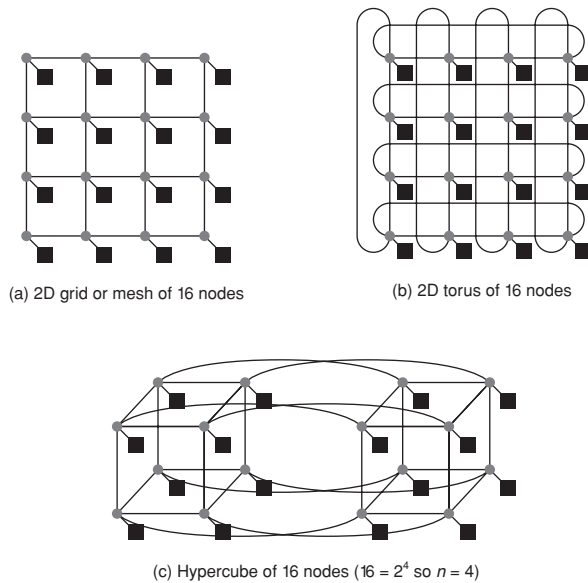

**Figure E.14** Direct network topologies that have appeared in commercial systems, mostly supercomputers. The shaded circles represent switches, and the black squares represent end node devices. Switches have many bidirectional network links, but at least one link goes to the end node device. These basic topologies can be supplemented with extra links to improve performance and reliability. For example, connecting the switches on the periphery of the 2-D mesh using the unused ports on each switch forms a 2-D torus. The hypercube topology is an  $n$ -dimensional interconnect for  $2^n$  nodes, requiring  $n + 1$  ports per switch: one for the  $n$  nearest neighbor nodes and one for the end node device.

**Answer** Using  $k \times k$  switches, the fat tree requires  $2N/k (\log_{k/2} N)$  switches, assuming the last stage (the root) has the same number of switches as each of the other stages. Given that the number of bidirectional ports in each switch is  $k$  (i.e., there are  $k$  input ports and  $k$  output ports for a  $k \times k$  switch) and that the switch cost grows quadratically with this, total network switch cost is proportional to  $2kN \log_{k/2} N$ . The link cost is  $N \log_{k/2} N$  as each of the  $\log_{k/2} N$  stages requires  $N$  bidirectional links, including those between the devices and the fat tree. The torus requires as many switches as nodes, each of them having  $2n + 1$  bidirectional ports, including the port to attach the communicating device, where  $n$  is the number of dimensions. Hence, total switch cost for the torus is  $(2n + 1)^2 N$ . Each of the torus nodes requires  $2n + 1$  bidirectional links for the  $n$  different dimensions and the connection for its end node device, but as the dimensional links are shared by two nodes, the total number of links is  $(2n/2 + 1)N = (n + 1)N$  bidirectional links for all  $N$  nodes. Thus, the relative costs of the torus topology with respect to the fat tree is

$$\text{Relative cost}_{\text{switches}} = (2n + 1)^2 N / 2kN \log_{k/2} N = (2n + 1)^2 / 2k \log_{k/2} N$$

$$\text{Relative cost}_{\text{links}} = (n + 1)N / N \log_{k/2} N = (n + 1) / \log_{k/2} N$$

When switch sizes are similar,  $2n + 1 \cong k$ . In this case, the relative cost is

$$\text{Relative cost}_{\text{switches}} = (2n + 1)^2 / 2k \log_{k/2} N = (2n + 1) / 2 \log_{k/2} N = k / 2 \log_{k/2} N$$

When the number of switch ports (also called *switch degree*) is small, tori have lower cost, particularly when the number of dimensions is low. This is an especially useful property when  $N$  is large. On the other hand, when larger switches and/or a high number of tori dimensions are used, fat trees are less costly and preferable. For example, when interconnecting 256 nodes, a fat tree is four times more expensive in terms of switch and link costs when  $4 \times 4$  switches are used. This higher cost is compensated for by lower network contention, on average. The fat tree is comparable in cost to the torus when  $8 \times 8$  switches are used (e.g., for interconnecting 256 nodes). For larger switch sizes beyond this, the torus costs more than the fat tree as each node includes a switch. This cost can be amortized by connecting multiple end node devices per switch, called *bristling*.

The topologies depicted in Figure E.14 all have in common the interesting characteristic of having their network links arranged in several orthogonal dimensions in a regular way. In fact, these topologies all happen to be particular instances of a larger class of direct network topologies known as  $k$ -ary  $n$ -cubes, where  $k$  signifies the number of nodes interconnected in each of the  $n$  dimensions. The symmetry and regularity of these topologies simplify network implementation (i.e., packaging) and packet routing as the movement of a packet along a given network dimension does not modify the number of remaining hops in any other dimension toward its destination. As we will see in the next section, this topological property can be readily exploited by simple routing algorithms.

Like their indirect counterpart, direct networks can introduce blocking among packets that concurrently request the same path, or part of it. The only exception is fully connected networks. The same way that the number of stages and switch hops in indirect networks can be reduced by using larger switches, the hop count in direct networks can likewise be reduced by increasing the number of topological dimensions via increased switch degree.

It may seem to be a good idea always to maximize the number of dimensions for a system of a certain size and switch cost. However, this is not necessarily the case. Most electronic systems are built within our three-dimensional (3D) world using planar (2D) packaging technology such as integrated circuit chips, printed circuit boards, and backplanes. Direct networks with up to three dimensions can be implemented using relatively short links within this 3D space, independent of system size. Links in higher-dimensioned networks would require increasingly longer wires or fiber. This increase in link length with system size is also indicative of MINs, including fat trees, which require either long links within all the stages or increasingly longer links as more stages are added. As we saw in the first example given in Section E.2, flow-controlled buffers increase in size pro-



portionally to link length, thus requiring greater silicon area. This is among the reasons why the supercomputer with the largest number of compute nodes existing in 2005, the IBM Blue Gene/L, implements a 3D torus network for interprocessor communication. A fat tree would have required much longer links, rendering a 64K node system less feasible. This highlights the importance of correctly selecting the proper network topology that meets system requirements.

Besides link length, other constraints derived from implementing the topology may also limit the degree to which a topology can scale. These are available *pin-out* and achievable *bisection bandwidth*. Pin count is a local restriction on the bandwidth of a chip, printed circuit board, and backplane (or chassis) connector. In a direct network that integrates processor cores and switches on a single chip or multichip module, pin bandwidth is used both for interfacing with main memory and for implementing node links. In this case, limited pin count could reduce the number of switch ports or bit lines per link. In an indirect network, switches are implemented separate from processor cores, allowing most of the pins to be dedicated to communication bandwidth. However, as switches are grouped onto boards, the aggregate of all input-output links of the switch fabric on a board for a given topology must not exceed the board connector pin-outs.

The bisection bandwidth is a more global restriction that gives the interconnect density and bandwidth that can be achieved by a given implementation (packaging) technology. Interconnect density and clock frequency are related to each other: when wires are packed closer together, crosstalk and parasitic capacitance increase, which usually impose a lower clock frequency. For example, the availability and spacing of metal layers limit wire density and frequency of on-chip networks, and copper track density limits wire density and frequency on a printed circuit board. To be implementable, the topology of a network must not exceed the available bisection bandwidth of the implementation technology. Most networks implemented to date are constrained more so by pin-out limitations rather than bisection bandwidth, particularly with the recent move to blade-based systems. Nevertheless, bisection bandwidth largely affects performance.

For a given topology, bisection bandwidth,  $BW_{\text{Bisection}}$ , is calculated by dividing the network into two roughly equal parts—each with half the nodes—and summing the bandwidth of the links crossing the imaginary dividing line. For nonsymmetric topologies, bisection bandwidth is the smallest of all pairs of equal-sized divisions of the network. For a fully connected network, the bisection bandwidth is proportional to  $N^2/2$  unidirectional links (or  $N^2/4$  bidirectional links), where  $N$  is the number of nodes. For a bus, bisection bandwidth is the bandwidth of just the one shared half-duplex link. For other topologies, values lie in between these two extremes. Network injection and reception bisection bandwidth is commonly used as a reference value, which is  $N/2$  for a network with  $N$  injection and reception links, respectively. Any network topology that provides this bisection bandwidth is said to have *full bisection bandwidth*.

Figure E.15 summarizes the number of switches and links required, the corresponding switch size, the maximum and average switch hop distances between nodes, and the bisection bandwidth in terms of links for several topologies discussed in this section for interconnecting 64 nodes.



Evaluation category	Bus	Ring	2D mesh	2D torus	Hypercube	Fat tree	Fully connected
Performance							
BW <sub>Bisection</sub> in # links	1	2	8	16	32	32	1024
Max (ave.) hop count	1 (1)	32 (16)	14 (7)	8 (4)	6 (3)	11 (9)	1 (1)
Cost							
I/O ports per switch	NA	3	5	5	7	4	64
Number of switches	NA	64	64	64	64	192	64
Number of net. links	1	64	112	128	192	320	2016
Total number of links	1	128	176	192	256	384	2080

**Figure E.15 Performance and cost of several network topologies for 64 nodes.** The bus is the standard reference at unit network link cost and bisection bandwidth. Values are given in terms of bidirectional links and ports. Hop count includes a switch and its output link, but not the injection link at end nodes. Except for the bus, values are given for the number of network links and total number of links, including injection/reception links between end node devices and the network.

## Effects of Topology on Network Performance

Switched network topologies require packets to take one or more hops to reach their destination, where each hop represents the transport of a packet through a switch and one of its corresponding links. Interestingly, each switch and its corresponding links can be modeled as a black box network connecting more than two devices, as was described in the previous section, where the term “devices” here refers to end nodes or other switches. The only differences are that the sending and receiving overheads are null through the switches, and the routing, switching, and arbitration delays are not cumulative but, instead, are delays associated with each switch.

As a consequence of the above, if the average packet has to traverse  $d$  hops to its destination, then  $T_R + T_A + T_S = (T_r + T_a + T_s) \times d$ , where  $T_r$ ,  $T_a$ , and  $T_s$  are the routing, arbitration, and switching delays, respectively, of a switch. With the assumption that pipelining over the network is staged on each hop at the packet level (this assumption will be challenged in the next section), the transmission delay is also increased by a factor of the number of hops. Finally, with the simplifying assumption that all injection links to the first switch or stage of switches and all links (including reception links) from the switches have approximately the same length and delay, the total propagation delay through the network  $T_{\text{TotalProp}}$  is the propagation delay through a single link,  $T_{\text{LinkProp}}$ , multiplied by  $d + 1$ , which is the hop count plus one to account for the injection link. Thus, the best-case lower-bound expression for average packet latency in the network (i.e., the latency in the absence of contention) is given by the following expression:

$$\text{Latency} = \text{Sending overhead} + T_{\text{LinkProp}} \times (d + 1) + (T_r + T_a + T_s) \times d + \frac{\text{Packet size}}{\text{Bandwidth}} \times (d + 1) + \text{Receiving overhead}$$

Again, the expression on page E-40 assumes that switches are able to pipeline packet transmission at the packet level.

Following the method presented previously, we can estimate the best-case upper bound for effective bandwidth by finding the narrowest section of the end-to-end network pipe. Focusing on the internal network portion of that pipe, network bandwidth is determined by the blocking properties of the topology. Non-blocking behavior can be achieved only by providing many alternative paths between every source-destination pair, leading to an aggregate network bandwidth that is many times higher than the aggregate network injection or reception bandwidth. This is quite costly. As this solution usually is prohibitively expensive, most networks have different degrees of blocking, which reduces the utilization of the aggregate bandwidth provided by the topology. This, too, is costly but not in terms of performance.

The amount of blocking in a network depends on its topology and the traffic distribution. Assuming the bisection bandwidth,  $BW_{\text{Bisection}}$ , of a topology is implementable (as typically is the case), it can be used as a constant measure of the maximum degree of blocking in a network. In the ideal case, the network always achieves full bisection bandwidth irrespective of the traffic behavior, thus transferring the bottlenecking point to the injection or reception links. However, as packets destined to locations in the other half of the network necessarily must cross the bisection links, those links pose as potential bottleneck links—potentially reducing the network bandwidth to below full bisection bandwidth. Fortunately, not all of the traffic must cross the network bisection, allowing more of the aggregate network bandwidth provided by the topology to be utilized. Also, network topologies with a higher number of bisection links tend to have less blocking as more alternative paths are possible to reach destinations and, hence, a higher percentage of the aggregate network bandwidth can be utilized. If only a fraction of the traffic must cross the network bisection, as captured by a *bisection traffic fraction* parameter  $\gamma$  ( $0 < \gamma \leq 1$ ), the network pipe at the bisection is, effectively, widened by the reciprocal of that fraction, assuming a traffic distribution that loads the bisection links at least as heavily, on average, as other network links. This defines the upper limit on achievable network bandwidth,  $BW_{\text{Network}}$ :

$$BW_{\text{Network}} = \frac{BW_{\text{Bisection}}}{\gamma}$$

Accordingly, the expression for effective bandwidth becomes the following when network topology is taken into consideration:

$$\text{Effective bandwidth} = \min\left(N \times BW_{\text{LinkInjection}}, \frac{BW_{\text{Bisection}}}{\gamma}, \sigma \times N \times BW_{\text{LinkReception}}\right)$$

It is important to note that  $\gamma$  depends heavily on the traffic patterns generated by applications. It is a measured quantity or calculated from detailed traffic analysis.

---

**Example** A common communication pattern in scientific programs is to have nearest neighbor elements of a two-dimensional array to communicate in a given direction. This pattern is sometimes called *NEWS communication*, standing for north,

east, west, and south—the directions on a compass. Map an  $8 \times 8$  array of elements one-to-one onto 64 end node devices interconnected in the following topologies: bus, ring, 2D mesh, 2D torus, hypercube, fully connected, and fat tree. How long does it take in the best case for each node to send one message to its northern neighbor and one to its eastern neighbor, assuming packets are allowed to use any minimal path provided by the topology? What is the corresponding effective bandwidth? Ignore elements that have no northern or eastern neighbors. To simplify the analysis, assume all networks experience unit packet transport time for each network hop—that is,  $T_{\text{LinkProp}}$ ,  $T_r$ ,  $T_a$ ,  $T_s$ , and packet transmission time for each hop sum to one. Also assume the delay through injection links is included in this unit time, and sending/receiving overhead is null.

**Answer** This communication pattern requires us to send  $2 \times (64 - 8)$  or 112 total packets—that is, 56 packets in each of the two communication phases: northward and eastward. The number of hops suffered by packets depends on the topology. Communication between sources and destinations are one-to-one, so  $\sigma$  is 100%. The injection and reception bandwidth cap the effective bandwidth to a maximum of 64 BW units (even though the communication pattern requires only 56 BW units). However, this maximum may get scaled down by the achievable network bandwidth, which is determined by the bisection bandwidth and the fraction of traffic crossing it,  $\gamma$ , both of which are topology dependent. Here are the various cases:

- *Bus*—The mapping of the  $8 \times 8$  array elements to nodes makes no difference for the bus as all nodes are equally distant at one hop away. However, the 112 transfers are done sequentially, taking a total of 112 time units. The bisection bandwidth is 1, and  $\gamma$  is 100%. Thus, effective bandwidth is only 1 BW unit.
- *Ring*—Assume the first row of the array is mapped to nodes 0 to 7, the second row to nodes 8 to 15, and so on. It takes just one time unit for all nodes simultaneously to send to their eastern neighbor (i.e., a transfer from node  $i$  to node  $i + 1$ ). With this mapping, the northern neighbor for each node is exactly eight hops away so it takes eight time units, which also is done in parallel for all nodes. Total communication time is, therefore, 9 time units. The bisection bandwidth is 2 bidirectional links (assuming a bidirectional ring), which is less than the full bisection bandwidth of 32 bidirectional links. For eastward communication, because only 2 of the eastward 56 packets must cross the bisection in the worst case, the bisection links do not pose as bottlenecks. For northward communication, 8 of the 56 packets must cross the two bisection links, yielding a  $\gamma$  of  $10/112 = 8.93\%$ . Thus, the network bandwidth is  $2/0.0893 = 22.4$  BW units. This limits the effective bandwidth at 22.4 BW units as well, which is less than half the bandwidth required by the communication pattern.
- *2D mesh*—There are eight rows and eight columns in our grid of 64 nodes, which is a perfect match to the NEWS communication. It takes a total of just 2 time units for all nodes to send simultaneously to their northern neighbors

followed by simultaneous communication to their eastern neighbors. The bisection bandwidth is 8 bidirectional links, which is less than full bisection bandwidth. However, the perfect matching of this nearest-neighbor communication pattern on this topology allows the maximum effective bandwidth to be achieved regardless. For eastward communication, 8 of the 56 packets must cross the bisection in the worst case, which does not exceed the bisection bandwidth. None of the northward communications cross the same network bisection, yielding a  $\gamma$  of  $8/112 = 7.14\%$  and a network bandwidth of  $8/0.0714 = 112$  BW units. The effective bandwidth is, therefore, limited by the communication pattern at 56 BW units as opposed to the mesh network.

- *2D torus*—Wrap-around links of the torus are not used for this communication pattern, so the torus has the same mapping and performance as the mesh.
- *Hypercube*—Assume elements in each row are mapped to the same location within the eight 3-cubes comprising the hypercube such that consecutive row elements are mapped to nodes only one hop away. Northern neighbors can be similarly mapped to nodes only one hop away in an orthogonal dimension. Thus, the communication pattern takes just 2 time units. The hypercube provides full bisection bandwidth of 32 links, but at most only 8 of the 112 packets must cross the bisection. Thus, effective bandwidth is limited only by the communication pattern to be 56 BW units, not by the hypercube network.
- *Fully connected*—Here, nodes are equally distant at one hop away, regardless of the mapping. Parallel transfer of packets in both the northern and eastern directions would take only 1 time unit if the injection and reception links could source and sink two packets at a time. As this is not the case, 2 time units are required. Effective bandwidth is limited by the communication pattern at 56 BW units, so the 1024 network bisection links largely go underutilized.
- *Fat tree*—Assume the same mapping of elements to nodes as is done for the ring and the use of switches with eight bidirectional ports. This allows simultaneous communication to eastern neighbors that takes at most three hops and, therefore, 3 time units through the three bidirectional stages interconnecting the eight nodes in each of the eight groups of nodes. The northern neighbor for each node resides in the adjacent group of eight nodes, which requires five hops, or 5 time units. Thus, the total time required on the fat tree is 8 time units. The fat tree provides full bisection bandwidth, so in the worst case of half the traffic needing to cross the bisection, an effective bandwidth of 56 BW units (as limited by the communication pattern and not by the fat-tree network) is achieved when packets are continually injected.

---

The above example should not lead one to the wrong conclusion that meshes are just as good as tori, hypercubes, fat trees, and other networks with higher bisection bandwidth. A number of simplifications that benefit low-bisection networks were assumed to ease the analysis. In practice, packets typically are larger than the link width and occupy links for many more than just one network cycle.

Company	System [network] name	Max. number of nodes [ $\times$ # CPUs]	Basic network topology	Injection [reception] node BW in MB/sec	# of data bits per link per direction	Raw network link BW per direction in MB/sec	Raw network bisection BW (bidirectional) in GB/sec
Intel	ASCI Red Paragon	4816 [ $\times$ 2]	2D mesh 64 $\times$ 64	400 [400]	16 bits	400	51.2
IBM	ASCI White SP Power3 [Colony]	512 [ $\times$ 16]	bidirectional MIN with 8-port bidirectional switches (typically a fat tree or Omega)	500 [500]	8 bits (+ 1 bit of control)	500	256
Intel	Thunder Itanium2 Tiger4 [QsNet <sup>II</sup> ]	1024 [ $\times$ 4]	fat tree with 8-port bidirectional switches	928 [928]	8 bits (+ 2 of control for 4b/5b encoding)	1333	1365
Cray	XT3 [SeaStar]	30,508 [ $\times$ 1]	3D torus 40 $\times$ 32 $\times$ 24	3200 [3200]	12 bits	3800	5836.8
Cray	X1E	1024 [ $\times$ 1]	4-way bristled 2D torus ( $\sim$ 23 $\times$ 11) with express links	1600 [1600]	16 bits	1600	51.2
IBM	ASC Purple pSeries 575 [Federation]	>1280 [ $\times$ 8]	bidirectional MIN with 8-port bidirectional switches (typically a fat tree or Omega)	2000 [2000]	8 bits (+ 2 bits of control for novel 5b/6b encoding scheme)	2000	2560
IBM	Blue Gene/L eServer Sol. [Torus Net.]	65,536 [ $\times$ 2]	3D torus 32 $\times$ 32 $\times$ 64	612.5 [1050]	1 bit (bit serial)	175	358.4

**Figure E.16** Topological characteristics of interconnection networks used in commercial high-performance machines.

Also, many communication patterns do not map so cleanly to the 2D mesh network topology; instead, usually they are more global and irregular in nature. These and other factors combine to increase the chances of packets blocking in low-bisection networks, increasing latency and reducing effective bandwidth.

To put this discussion on topologies into further perspective, Figure E.16 lists various attributes of topologies used in commercial high-performance computers.

## Network Routing, Arbitration, and Switching

Routing, arbitration, and switching are performed at every switch along a packet's path in a switched media network, no matter what the network topology. Numerous interesting techniques for accomplishing these network functions have been proposed in the literature. In this section, we focus on describing a representative set of approaches used in commercial systems for the more commonly used network topologies. Their impact on performance is also highlighted.

### Routing

The *routing algorithm* defines which network path, or paths, are allowed for each packet. Ideally, the routing algorithm supplies shortest paths to all packets such that traffic load is evenly distributed across network links to minimize contention. However, some paths provided by the network topology may not be allowed in order to guarantee that all packets can be delivered, no matter what the traffic behavior. Paths that have an unbounded number of allowed nonminimal hops from packet sources, for instance, may result in packets never reaching their destinations. This situation is referred to as *livelock*. Likewise, paths that cause a set of packets to block in the network forever waiting only for network resources (i.e., links or associated buffers) held by other packets in the set also prevent packets from reaching their destinations. This situation is referred to as *deadlock*. As deadlock arises due to the finiteness of network resources, the probability of its occurrence increases with increased network traffic and decreased availability of network resources. For the network to function properly, the routing algorithm must guard against this anomaly, which can occur in various forms—for example, routing deadlock, request-reply (protocol) deadlock, and fault-induced (reconfiguration) deadlock, etc. At the same time, for the network to provide the highest possible performance, the routing algorithm must be efficient—allowing as many routing options to packets as there are paths provided by the topology, in the best case.

The simplest way of guarding against livelock is to restrict routing such that only minimal paths from sources to destinations are allowed or, less restrictively, only a limited number of nonminimal hops. The strictest form has the added benefit of consuming the minimal amount of network bandwidth, but it prevents packets from being able to use alternative nonminimal paths in case of contention or faults along the shortest (minimal) paths.

Deadlock is more difficult to guard against. Two common strategies are used in practice: avoidance and recovery. In *deadlock avoidance*, the routing algorithm restricts the paths allowed by packets to only those that keep the global network state deadlock-free. A common way of doing this consists of establishing an ordering between a set of resources—the minimal set necessary to support network full access—and granting those resources to packets in some total or partial order such that cyclic dependency cannot form on those resources. This allows an

escape path always to be supplied to packets no matter where they are in the network to avoid entering a deadlock state. In *deadlock recovery*, resources are granted to packets without regard for avoiding deadlock. Instead, as deadlock is possible, some mechanism is used to detect the likely existence of deadlock. If detected, one or more packets are removed from resources in the deadlock set—possibly by regressively dropping the packets or by progressively redirecting the packets onto special deadlock recovery resources. The freed network resources are then granted to other packets needing them to resolve the deadlock.

Let us consider routing algorithms designed for distributed switched networks. Figure E.17 (a) illustrates one of many possible deadlocked configurations for packets within a region of a 2D mesh network. The routing algorithm can avoid all such deadlocks (and livelocks) by allowing only the use of minimal paths that cross the network dimensions in some total order. That is, links of a given dimension are not supplied to a packet by the routing algorithm until no other links are needed by the packet in all of the preceding dimensions for it to reach its destination. This is illustrated in Figure E.17 (b), where dimensions are crossed in  $XY$  dimension order. All the packets must follow the same order when traversing dimensions, exiting a dimension only when links are no longer required in that dimension. This well-known algorithm is referred to as *dimension-order routing* (DOR) or *e-cube routing* in hypercubes. It is used in many commercial systems built from distributed switched networks and on-chip networks. As this routing algorithm always supplies the same path for a given source-destination pair, it is a *deterministic routing* algorithm.

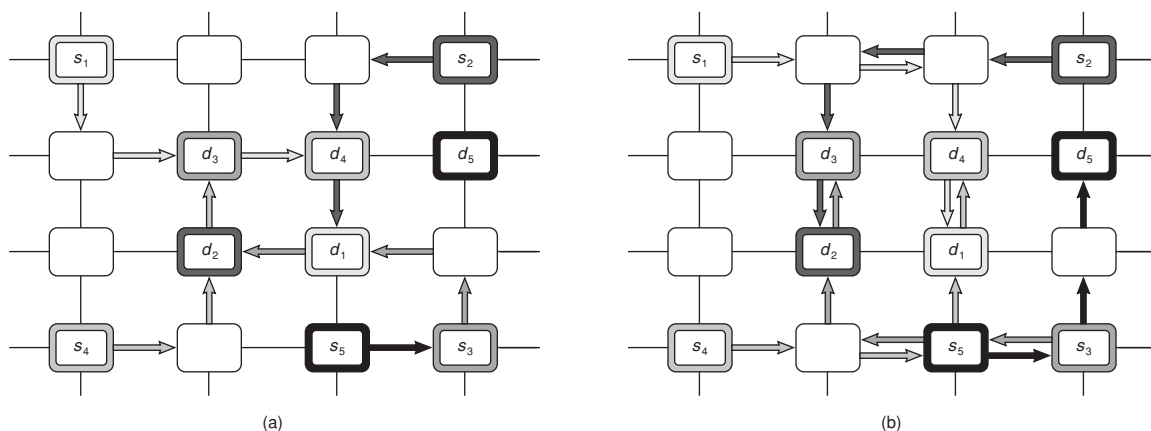

**Figure E.17** A mesh network with packets routing from sources,  $s_i$ , to destinations,  $d_i$ . (a) Deadlock forms from packets destined to  $d_1$  through  $d_4$  blocking on others in the same set that fully occupy their requested buffer resources one hop away from their destinations. This deadlock cycle causes other packets needing those resources also to block, like packets from  $s_5$  destined to  $d_5$  that have reached node  $s_3$ . (b) Deadlock is avoided using dimension-order routing. In this case, packets exhaust their routes in the  $X$  dimension before turning into the  $Y$  dimension in order to complete their routing.



Crossing dimensions in order on some minimal set of resources required to support network full access avoids deadlock in meshes and hypercubes. However, for distributed switched topologies that have wrap-around links (e.g., rings and tori), a total ordering on a minimal set of resources within each dimension is also needed if resources are to be used to full capacity. Alternatively, some empty resources or *bubbles* along the dimensions would be required to remain below full capacity and avoid deadlock. To allow full access, either the physical links must be duplicated or the logical buffers associated with each link must be duplicated, resulting in *physical channels* or *virtual channels*, respectively, on which the ordering is done. Ordering is not necessary on all network resources to avoid deadlock—it is needed only on some minimal set required to support network full access (i.e., some *escape resource set*). Routing algorithms based on this technique (called Duato’s Protocol) can be defined that allow alternative paths provided by the topology to be used for a given source-destination pair in addition to the escape resource set. One of those allowed paths must be selected, preferably the most efficient one. Adapting the path in response to prevailing network traffic conditions enables the aggregate network bandwidth to be better utilized and contention to be reduced. Such routing capability is referred to as *adaptive routing* and is used in many commercial systems.

---

**Example** How many of the possible dimensional turns are eliminated by dimension-order routing on an  $n$ -dimensional mesh network? What is the fewest number of turns that actually need to be eliminated while still maintaining connectedness and deadlock freedom? Explain using a 2D mesh network.

**Answer** The dimension-order routing algorithm eliminates exactly half of the possible dimensional turns as it is easily proven that all turns from any lower-ordered dimension into any higher-ordered dimension are allowed, but the converse is not true. For example, of the eight possible turns in the 2D mesh shown in Figure E.17, the four turns from  $X+$  to  $Y+$ ,  $X+$  to  $Y-$ ,  $X-$  to  $Y+$ , and  $X-$  to  $Y-$  are allowed, where the signs (+ or -) refer to the direction of travel within a dimension. The four turns from  $Y+$  to  $X+$ ,  $Y+$  to  $X-$ ,  $Y-$  to  $X+$ , and  $Y-$  to  $X-$  are disallowed turns. The elimination of these turns prevents cycles of any kind from forming—and, thus, avoids deadlock—while keeping the network connected. However, it does so at the expense of not allowing any routing adaptivity.

The *Turn Model* routing algorithm proves that the minimum number of eliminated turns to prevent cycles and maintain connectedness is a quarter of the possible turns, but the right set of turns must be chosen. Only some particular set of eliminated turns allow both requirements to be satisfied. With the elimination of the wrong set of a quarter of the turns, it is possible for combinations of allowed turns to emulate the eliminated ones (and, thus, form cycles and deadlock) or for the network not to be connected. For the 2D mesh, for example, it is possible to eliminate only the two turns ending in the westward direction (i.e.,  $Y+$  to  $X-$  and  $Y-$  to  $X-$ ) by requiring packets to start their routes in the westward direction (if needed) to maintain connectedness. Alternatives to this West-First routing for 2D



meshes are Negative-First routing and North-Last routing. For these, the extra quarter of turns beyond that supplied by DOR allows for partial adaptivity in routing, making these adaptive routing algorithms.

---

Routing algorithms for centralized switched networks can similarly be defined to avoid deadlocks by restricting the use of resources in some total or partial order. For fat trees, resources can be totally ordered along paths starting from the input leaf stage upward to the root and then back down to the output leaf stage. The routing algorithm can allow packets to use resources in increasing partial order, first traversing up the tree until they reach some *least common ancestor* (LCA) of the source and destination, and then back down the tree until they reach their destinations. As there are many least common ancestors for a given destination, multiple alternative paths are allowed while going up the tree, making the routing algorithm adaptive. However, only a single deterministic path to the destination is provided by the fat tree topology from a least common ancestor. This *self-routing* property is common to many MINs and can be readily exploited: the switch output port at each stage is given simply by shifts of the destination node address.

More generally, a tree graph can be mapped onto any topology—whether direct or indirect—and links between nodes at the same tree level can be allowed by assigning directions to them, where “up” designates paths moving toward the tree root and “down” designates paths moving away from the root node. This allows for generic *up\*/down\* routing* to be defined on any topology such that packets follow paths (possibly adaptively) consisting of zero or more up links followed by zero or more down links to their destination. Up/down ordering prevents cycles from forming, avoiding deadlock. This routing technique was used in Autonet—a self-configuring switched LAN—and in early Myrinet SANs.

Routing algorithms are implemented in practice by a combination of the routing information placed in the packet header by the source node and the routing control mechanism incorporated in the switches. For *source routing*, the entire routing path is precomputed by the source—possibly by table lookup—and placed in the packet header. This usually consists of the output port or ports supplied for each switch along the predetermined path from the source to the destination, which can be stripped off by the routing control mechanism at each switch. An additional bit field can be included in the header to signify whether adaptive routing is allowed (i.e., that any one of the supplied output ports can be used). For *distributed routing*, the routing information usually consists of the destination address. This is used by the routing control mechanism in each switch along the path to determine the next output port, either by computing it using a finite-state machine or by looking it up in a local routing table (i.e., forwarding table). Compared to distributed routing, source routing simplifies the routing control mechanism within the network switches, but it requires more routing bits in the header of each packet, thus increasing the header overhead.

## Arbitration

The *arbitration algorithm* determines when requested network paths are available for packets. Ideally, arbiters maximize the matching of free network resources and packets requesting those resources. At the switch level, arbiters maximize the matching of free output ports and packets located in switch input ports requesting those output ports. When all requests cannot be granted simultaneously, switch arbiters resolve conflicts by granting output ports to packets in a fair way such that *starvation* of requested resources by packets is prevented. This could happen to packets in shorter queues if a serve-longest-queue (SLQ) scheme is used. For packets having the same priority level, simple round-robin (RR) or age-based schemes are sufficiently fair and straightforward to implement.

Arbitration can be distributed to avoid centralized bottlenecks. A straightforward technique consists of two phases: a request phase and a grant phase. Let us assume that each switch input port has an associated queue to hold incoming packets and that each switch output port has an associated local arbiter implementing a round-robin strategy. Figure E.18 (a) shows a possible set of requests for a four-port switch. In the *request phase*, packets at the head of each input port queue send a single request to the arbiters corresponding to the output ports requested by them. Then, each output port arbiter independently arbitrates among the requests it receives, selecting only one. In the *grant phase*, one of the requests to each arbiter is granted the requested output port. When two packets from different input ports request the same output port, only one receives a grant, as shown in the figure. As a consequence, some output port bandwidth remains unused even though all input queues have packets to transmit.

The simple two-phase technique can be improved by allowing several simultaneous requests to be made by each input port, possibly coming from different virtual channels or from multiple adaptive routing options. These requests are

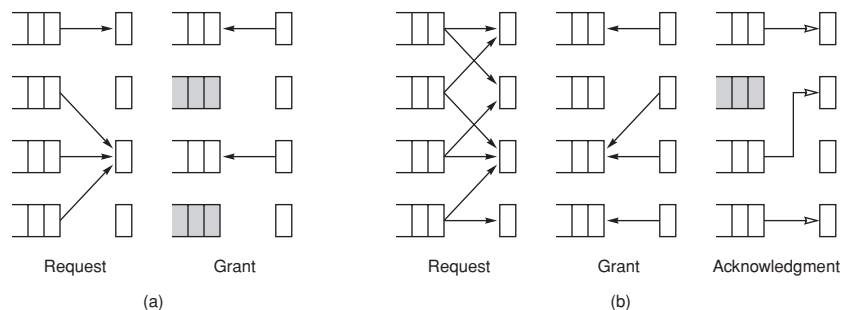

**Figure E.18** Two arbitration techniques. (a) Two-phased arbitration in which two of the four input ports are granted requested output ports. (b) Three-phased arbitration in which three of the four input ports are successful in gaining the requested output ports, resulting in higher switch utilization.

sent to different output port arbiters. By submitting more than one request per input port, the probability of matching increases. Now, arbitration requires three phases: request, grant, and acknowledgment. Figure E.18 (b) shows the case in which up to two requests can be made by packets at each input port. In the request phase, requests are submitted to output port arbiters and these arbiters select one of the received requests, as is done for the two-phase arbiter. Likewise, in the grant phase, the selected requests are granted to the corresponding requesters. Taking into account that an input port can submit more than one request, it may receive more than one grant. Thus, it selects among possibly multiple grants using some arbitration strategy such as round-robin. The selected grants are confirmed to the corresponding output port arbiters in the acknowledgment phase.

As can be seen in Figure E.18 (b), it could happen that an input port that submits several requests does not receive any grants, while some of the requested ports remain free. Because of this, a second arbitration iteration can improve the probability of matching. In this iteration, only the requests corresponding to non-matched input and output ports are submitted. Iterative arbiters with multiple requests per input port are able to increase the utilization of switch output ports and, thus, the network link bandwidth. However, this comes at the expense of additional arbiter complexity and increased arbitration delay, which could increase the router clock cycle time if it is on the critical path.

## Switching

The *switching technique* defines how connections are established in the network. Ideally, connections between network resources are established or “switched in” only for as long as they are actually needed and exactly at the point that they are ready and needed to be used, considering both time and space. This allows efficient use of available network bandwidth by competing traffic flows and minimal latency. Connections at each hop along the topological path allowed by the routing algorithm and granted by the arbitration algorithm can be established in three basic ways: prior to packet arrival using *circuit switching*, upon receipt of the entire packet using *store-and-forward packet switching*, or upon receipt of only portions of the packet with unit size no smaller than that of the packet header using *cut-through packet switching*.

Circuit switching establishes a circuit a priori such that network bandwidth is allocated for packet transmissions along an entire source-destination path. It is possible to pipeline packet transmission across the circuit using staging at each hop along the path, a technique known as *pipelined circuit switching*. As routing, arbitration, and switching are performed only once for one or more packets, routing bits are not needed in the header of packets, thus reducing latency and overhead. This can be very efficient when information is continuously transmitted between devices for the same circuit setup. However, as network bandwidth is removed from the shared pool and preallocated regardless of whether sources are in need of consuming it or not, circuit switching can be very inefficient and highly wasteful of bandwidth.

Packet switching enables network bandwidth to be shared and used more efficiently when packets are transmitted intermittently, which is the more common case. Packet switching comes in two main varieties—store-and-forward and cut-through switching, both of which allow network link bandwidth to be multiplexed on packet-sized or smaller units of information. This better enables bandwidth sharing by packets originating from different sources. The finer granularity of sharing, however, increases the overhead needed to perform switching: routing, arbitration, and switching must be performed for every packet, and routing and flow control bits are required for every packet if flow control is used.

Store-and-forward packet switching establishes connections such that a packet is forwarded to the next hop in sequence along its source-destination path only after the entire packet is first stored (staged) at the receiving switch. As packets are completely stored at every switch before being transmitted, links are completely decoupled, allowing full link bandwidth utilization even if links have very different bandwidths. This property is very important in WANs, but the price to pay is packet latency; the total routing, arbitration, and switching delay is multiplicative with the number of hops, as we have seen in Section E.4 when analyzing performance under this assumption.

Cut-through packet switching establishes connections such that a packet can “cut through” switches in a pipelined manner once the header portion of the packet (or equivalent amount of payload trailing the header) is staged at receiving switches. That is, the rest of the packet need not arrive before switching in the granted resources. This allows routing, arbitration, and switching delay to be additive with the number of hops rather than multiplicative to reduce total packet latency. Cut-through comes in two varieties, the main differences being the size of the unit of information on which flow control is applied and, consequently, the buffer requirements at switches. *Virtual cut-through switching* implements flow control at the packet level, whereas *wormhole switching* implements it on flow units, or *flits*, which are smaller than the maximum packet size but usually at least as large as the packet header. Since wormhole switches need to be capable of storing only a small portion of a packet, packets that block in the network may span several switches. This can cause other packets to block on the links they occupy, leading to premature network saturation and reduced effective bandwidth unless some centralized buffer is used within the switch to store them—a technique called *buffered wormhole switching*. As chips can implement relatively large buffers in current technology, virtual cut-through is the more commonly used switching technique. However, wormhole switching may still be preferred in OCNs designed to minimize silicon resources.

Premature network saturation caused by wormhole switching can be mitigated by allowing several packets to share the physical bandwidth of a link simultaneously via time-multiplexed switching at the flit level. This requires physical links to have a set of virtual channels (i.e., the logical buffers mentioned previously) at each end, into which packets are switched. Before, we saw how virtual channels can be used to decouple physical link bandwidth from buffered packets in such a way as to avoid deadlock. Now, virtual channels are multiplexed in such

a way that bandwidth is switched in and used by flits of a packet to advance even though the packet may share some links in common with a blocked packet ahead. This, again, allows network bandwidth to be used more efficiently, which, in turn, reduces the average packet latency.

## Impact on Network Performance

Routing, arbitration, and switching can impact the packet latency of a loaded network by reducing the contention delay experienced by packets. For an unloaded network that has no contention, the algorithms used to perform routing and arbitration have no impact on latency other than to determine the amount of delay incurred in implementing those functions at switches—typically, the pin-to-pin latency of a switch chip is several tens of nanoseconds. The only change to the best-case packet latency expression given in the previous section comes from the switching technique. Store-and-forward packet switching was assumed before in which transmission delay for the entire packet is incurred on all  $d$  hops plus at the source node. For cut-through packet switching, transmission delay is pipelined across the network links comprising the packet's path at the granularity of the packet header instead of the entire packet. Thus, this delay component is reduced, as shown in the following lower-bound expression for packet latency:

$$\text{Latency} = \text{Sending overhead} + T_{\text{LinkProp}} \times (d + 1) + (T_r + T_a + T_s) \times d + \frac{\text{Packet} + (d \times \text{Header})}{\text{Bandwidth}} + \text{Receiving overhead}$$

The effective bandwidth is impacted by how efficiently routing, arbitration, and switching allow network bandwidth to be used. The routing algorithm can distribute traffic more evenly across a loaded network to increase the utilization of the aggregate bandwidth provided by the topology—particularly, by the bisection links. The arbitration algorithm can maximize the number of switch output ports that accept packets, which also increases the utilization of network bandwidth. The switching technique can increase the degree of resource sharing by packets, which further increases bandwidth utilization. These combine to affect network bandwidth,  $\text{BW}_{\text{Network}}$ , by an *efficiency factor*,  $\rho$ , where  $0 < \rho \leq 1$ :

$$\text{BW}_{\text{Network}} = \rho \times \frac{\text{BW}_{\text{Bisection}}}{\gamma}$$

The efficiency factor  $\rho$  is difficult to calculate or to quantify by means other than simulation. Nevertheless, with this parameter we can estimate the best-case upper-bound effective bandwidth by using the following expression that takes into account the effects of routing, arbitration, and switching:

$$\text{Effective bandwidth} = \min\left(N \times \text{BW}_{\text{LinkInjection}}, \rho \times \frac{\text{BW}_{\text{Bisection}}}{\gamma}, \sigma \times N \times \text{BW}_{\text{LinkReception}}\right)$$

We note that  $\rho$  also depends on how well the network handles the traffic generated by applications. For instance,  $\rho$  could be higher for circuit switching than for cut-through switching if large streams of packets are continually transmitted between a source-destination pair, whereas the converse could be true if packets are transmitted intermittently.

---

**Example** Compare the performance of deterministic routing versus adaptive routing for a 3D torus network interconnecting 4096 nodes. Do so by plotting latency versus applied load and throughput versus applied load. Also compare the efficiency of the best and worst of these networks. Assume virtual cut-through switching, three-phase arbitration, and virtual channels are implemented. Consider separately the cases for two and four virtual channels, respectively. Assume that one of the virtual channels uses bubble flow control in dimension order so as to avoid deadlock; the other virtual channel(s) are used either in dimension order (for deterministic routing) or minimally along shortest paths (for adaptive routing), as is done in the IBM Blue Gene/L torus network.

**Answer** It is very difficult to compute analytically the performance of routing algorithms given that their behavior depends on several network design parameters with complex interdependences among them. As a consequence, designers typically resort to cycle-accurate simulators to evaluate performance. One way to evaluate the effect of a certain design decision is to run sets of simulations over a range of network loads, each time modifying one of the design parameters of interest while keeping the remaining ones fixed. The use of synthetic traffic loads is quite frequent in these evaluations as it allows the network to stabilize at a certain working point and for behavior to be analyzed in detail. This is the method we use here (alternatively, trace-driven or execution-driven simulation can be used).

Figure E.19 shows the typical interconnection network performance plots. On the left, average packet latency (expressed in network cycles) is plotted as a function of applied load (traffic generation rate) for the two routing algorithms with two and four virtual channels each; on the right, throughput (traffic delivery rate) is similarly plotted. Applied load is normalized by dividing it by the number of nodes in the network (i.e., bytes per cycle per node). Simulations are run under the assumption of uniformly distributed traffic consisting of 256-byte packets, where flits are byte sized. Routing, arbitration, and switching delays are assumed to sum to 1 network cycle per hop while time of flight delay over each link is assumed to be 10 cycles. Link bandwidth is 1 byte per cycle, thus providing results that are independent of network clock frequency.

As can be seen, the plots within each graph have similar characteristic shapes, but they have different values. For the latency graph, all start at the no-load latency as predicted by the latency expression given above, then slightly increase with traffic load as contention for network resources increases. At higher applied loads, latency increases exponentially, and the network approaches its saturation point as it is unable to absorb the applied load, causing packets to queue up at their source nodes awaiting injection. In these simulations, the queues keep growing over time, making latency tend toward infinity. However, in practice, queues reach their capacity and trigger the application to stall further packet generation, or the application throttles itself waiting for acknowledgments/responses to outstanding packets. Nevertheless, latency grows at a slower rate for adaptive routing as alternative paths are provided to packets along congested resources.

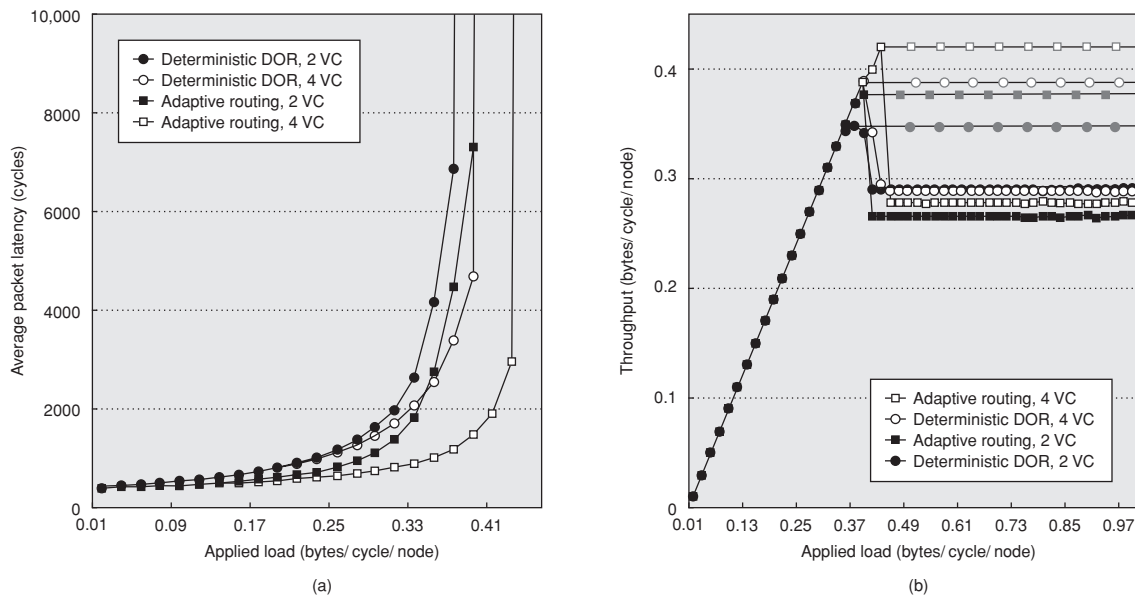

**Figure E.19** Deterministic routing is compared against adaptive routing, both with either two or four virtual channels, assuming uniformly distributed traffic on a 4K node 3D torus network with virtual cut-through switching and bubble flow control to avoid deadlock. (a) Average latency is plotted versus applied load, and (b) throughput is plotted versus applied load (the upper grayish plots show peak throughput, and the lower black plots show sustained throughput). Simulation data were collected by P. Gilabert and J. Flich at the Universidad Politècnica de València, Spain (2006).

For this same reason, adaptive routing allows the network to reach a higher peak throughput for the same number of virtual channels as compared to deterministic routing. At nonsaturation loads, throughput increases fairly linearly with applied load. When the network reaches its saturation point, however, it is unable to deliver traffic at the same rate at which traffic is generated. The saturation point, therefore, indicates the maximum achievable or “peak” throughput, which would be no more than that predicted by the effective bandwidth expression given above. Beyond saturation, throughput tends to drop as a consequence of massive head-of-line blocking across the network (as will be explained further in Section E.6), very much like cars tend to advance more slowly at rush hour. This is an important region of the throughput graph as it shows how significant of a performance drop the routing algorithm can cause if congestion management techniques (discussed briefly in Section E.7) are not used effectively. In this case, adaptive routing has more of a performance drop after saturation than deterministic routing, as measured by the postsaturation sustained throughput.

For both routing algorithms, more virtual channels (i.e., four) give packets a greater ability to pass over blocked packets ahead, allowing for a higher peak throughput as compared to fewer virtual channels (i.e., two). For adaptive routing



with four virtual channels, the peak throughput of 0.43 bytes/cycle/node is near the maximum of 0.5 bytes/cycle/node that can be obtained with 100% efficiency (i.e.,  $\rho = 100\%$ ), assuming there is enough injection and reception bandwidth to make the network bisection the bottlenecking point. In that case, the network bandwidth is simply 100% times the network bisection bandwidth ( $BW_{\text{Bisection}}$ ) divided by the fraction of traffic crossing the bisection ( $\gamma$ ), as given by the expression above. Taking into account that the bisection splits the torus into two equally sized halves,  $\gamma$  is equal to 0.5 for uniform traffic as only half the injected traffic is destined to a node at the other side of the bisection. The  $BW_{\text{Bisection}}$  for a 4096-node 3D torus network is  $16 \times 16 \times 4$  unidirectional links times the link bandwidth (i.e., 1 byte/cycle). If we normalize the bisection bandwidth by dividing it by the number of nodes (as we did with network bandwidth), the  $BW_{\text{Bisection}}$  is 0.25 bytes/cycle/node. Dividing this by  $\gamma$  gives the ideal maximally obtainable network bandwidth of 0.5 bytes/cycle/node.

We can find the efficiency factor,  $\rho$ , of the simulated network simply by dividing the measured peak throughput by the ideal throughput. The efficiency factor for the network with fully adaptive routing and four virtual channels is  $0.43/(0.25/0.5) = 86\%$ , whereas for the network with deterministic routing and two virtual channels it is  $0.37/(0.25/0.5) = 74\%$ . Besides the 12% difference in efficiency between the two, another 14% gain in efficiency might be obtained with even better routing, arbitration, switching, and virtual channel designs.

---

To put this discussion on routing, arbitration, and switching in perspective, Figure E.20 lists the techniques used in SANs designed for commercial high-performance computers. In addition to being applied to the SANs as shown in the figure, the issues discussed in this section also apply to other interconnect domains: from OCNs to WANs.

## E.6

### Switch Microarchitecture

Network switches implement the routing, arbitration, and switching functions of switched-media networks. Switches also implement buffer management mechanisms and, in the case of lossless networks, the associated flow control. For some networks, switches also implement part of the network management functions that explore, configure, and reconfigure the network topology in response to boot-up and failures. Here, we reveal the internal structure of network switches by describing a basic switch microarchitecture and various alternatives suitable for different routing, arbitration, and switching techniques presented previously.

#### Basic Switch Microarchitecture

The internal data path of a switch provides connectivity among the input and output ports. Although a shared bus or a multiported central memory could be used, these solutions are insufficient or too expensive, respectively, when the required



Company	System [network] name	Max. number of nodes [× # CPUs]	Basic network topology	Switch queuing (buffers)	Network routing algorithm	Switch arbitration technique	Network switching technique
Intel	ASCI Red Paragon	4510 [× 2]	2D mesh 64 × 64	input buffered (1 flit)	distributed dimension-order routing	2-phased RR, distributed across switch	wormhole with no virtual channels
IBM	ASCI White SP Power3 [Colony]	512 [× 16]	bidirectional MIN with 8-port bidirectional switches (typically a fat-tree or Omega)	input and central buffer with output queuing (8-way speedup)	source-based LCA adaptive, shortest-path routing and table-based multicast routing	2-phased RR, centralized and distributed at outputs for bypass paths	buffered wormhole and virtual cut-through for multicasting, no virtual channels
Intel	Thunder Itanium2 Tiger4 [QsNet <sup>II</sup> ]	1024 [× 4]	fat tree with 8-port bidirectional switches	input buffered	source-based LCA adaptive, shortest-path routing	2-phased RR, priority, aging, distributed at output ports	wormhole with 2 virtual channels
Cray	XT3 [SeaStar]	30,508 [× 1]	3D torus 40 × 32 × 24	input with staging output	distributed table-based dimension-order routing	2-phased RR, distributed at output ports	virtual cut-through with 4 virtual channels
Cray	X1E	1024 [× 1]	4-way bristled 2D torus (~ 23 × 11) with express links	input with virtual output queuing	distributed table-based dimension-order routing	2-phased wavefront (pipelined) global arbiter	virtual cut-through with 4 virtual channels
IBM	ASC Purple pSeries 575 [Federation]	>1280 [× 8]	bidirectional MIN with 8-port bidirectional switches (typically a fat tree or Omega)	input and central buffer with output queuing (8-way speedup)	source and distributed table-based LCA adaptive, shortest-path routing and multicast	2-phased RR, centralized and distributed at outputs for bypass paths	buffered wormhole and virtual cut-through for multicasting with 8 virtual channels
IBM	Blue Gene/L eServer Solution [Torus Net.]	65,536 [× 2]	3D torus 32 × 32 × 64	input-output buffered	distributed, adaptive with bubble escape virtual channel	2-phased SLQ, distributed at input and output	virtual cut-through with 4 virtual channels

**Figure E.20** Routing, arbitration, and switching characteristics of interconnections networks in commercial machines.

aggregate switch bandwidth is high. Most high-performance switches implement an internal crossbar to provide nonblocking connectivity within the switch, thus allowing concurrent connections between multiple input-output port pairs. Buffering of blocked packets can be done using FIFO or circular queues, which can be implemented as *dynamically allocatable multi-queues* (DAMQs) in static

RAM to provide high capacity and flexibility. These queues can be placed at input ports (i.e., *input buffered switch*), output ports (i.e., *output buffered switch*), centrally within the switch (i.e., *centrally buffered switch*), or at both the input and output ports of the switch (i.e., *input-output buffered switch*). Figure E.21 shows a block diagram of an input-output buffered switch.

Routing can be implemented using a finite-state machine or forwarding table within the routing control unit of switches. In the former case, the routing information given in the packet header is processed by a finite-state machine that determines the allowed switch output port (or ports if routing is adaptive), according to the routing algorithm. Portions of the routing information in the header are usually stripped off or modified by the routing control unit after use to simplify processing at the next switch along the path. When routing is implemented using forwarding tables, the routing information given in the packet header is used as an address to access a forwarding table entry that contains the allowed switch output port(s) provided by the routing algorithm. Forwarding tables must be preloaded into the switches at the outset of network operation. The routing control unit is usually implemented as a centralized resource, although it could be replicated at every input port so as not to become a bottleneck. Routing is done only once for every packet, and packets typically are large enough to take several cycles to flow through the switch, so a centralized routing control unit rarely becomes a bottleneck. Figure E.21 assumes a centralized routing control unit within the switch.

Arbitration is required when two or more packets concurrently request the same output port, as described in the previous section. Switch arbitration can be implemented in a centralized or distributed way. In the former case, all of the

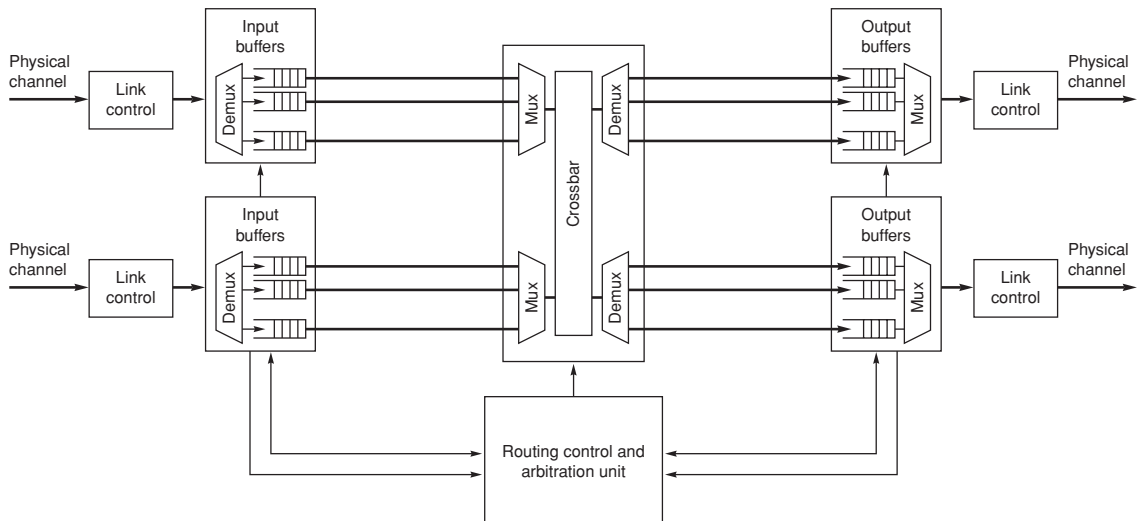

**Figure E.21** Basic microarchitectural components of an input-output-buffered switch.

requests and status information are transmitted to the central switch arbitration unit; in the latter case, the arbiter is distributed across the switch, usually among the input and/or output ports. Arbitration may be performed multiple times on packets, and there may be multiple queues associated with each input port, increasing the number of arbitration requests that must be processed. Thus, many implementations use a hierarchical arbitration approach, where arbitration is first performed locally at every input port to select just one request among the corresponding packets and queues, and later arbitration is performed globally to process the requests made by each of the local input port arbiters. Figure E.21 assumes a centralized arbitration unit within the switch.

The basic switch microarchitecture depicted in Figure E.21 functions in the following way. When a packet starts to arrive at a switch input port, the link controller decodes the incoming signal and generates a sequence of bits, possibly deserializing data to adapt them to the width of the internal data path if different from the external link width. Information is also extracted from the packet header or link control signals to determine the queue to which the packet should be buffered. As the packet is being received and buffered (or after the entire packet has been buffered, depending on the switching technique), the header is sent to the routing unit. This unit supplies a request for one or more output ports to the arbitration unit. Arbitration for the requested output port succeeds if the port is free and has enough space to buffer the entire packet or flit, depending on the switching technique. If wormhole switching with virtual channels is implemented, additional arbitration and allocation steps may be required for the transmission of each individual flit. Once the resources are allocated, the packet is transferred across the internal crossbar to the corresponding output buffer and link if no other packets are ahead of it and the link is free. Link-level flow control implemented by the link controller prevents input queue overflow at the neighboring switch on the other end of the link. If virtual channel switching is implemented, several packets may be time-multiplexed across the link on a flit-by-flit basis. As the various input and output ports operate independently, several incoming packets may be processed concurrently in the absence of contention.

## Buffer Organizations

As mentioned above, queues can be located at the switch input, output, or both sides. Output-buffered switches have the advantage of completely eliminating *head-of-line blocking*. Head-of-line (HOL) blocking occurs when two or more packets are buffered in a queue, and a blocked packet at the head of the queue blocks other packets in the queue that would otherwise be able to advance if they were at the queue head. This cannot occur in output-buffered switches as all the packets in a given queue have the same status; they require the same output port. However, it may be the case that all the switch input ports simultaneously receive a packet for the same output port. As there are no buffers at the input side, output buffers must be able to store all those incoming packets at the same time. This requires implementing output queues with an internal switch *speedup* of  $k$ . That

is, output queues must have a write bandwidth  $k$  times the link bandwidth, where  $k$  is the number of switch ports. This oftentimes is too expensive. Hence, this solution by itself has rarely been implemented in lossless networks. As the probability of concurrently receiving many packets for the same output port is usually small, commercial systems that use output-buffered switches typically implement only moderate switch speedup, dropping packets on rare buffer overflow.

Switches with buffers on the input side are able to receive packets without having any switch speedup. However, HOL blocking can occur within input port queues, as illustrated in Figure E.22 (a). This can reduce switch output port utilization to less than 60% even when packet destinations are uniformly distributed. As shown in Figure E.22 (b), the use of virtual channels (two in this case) can mitigate HOL blocking but does not eliminate it. A more effective solution is to

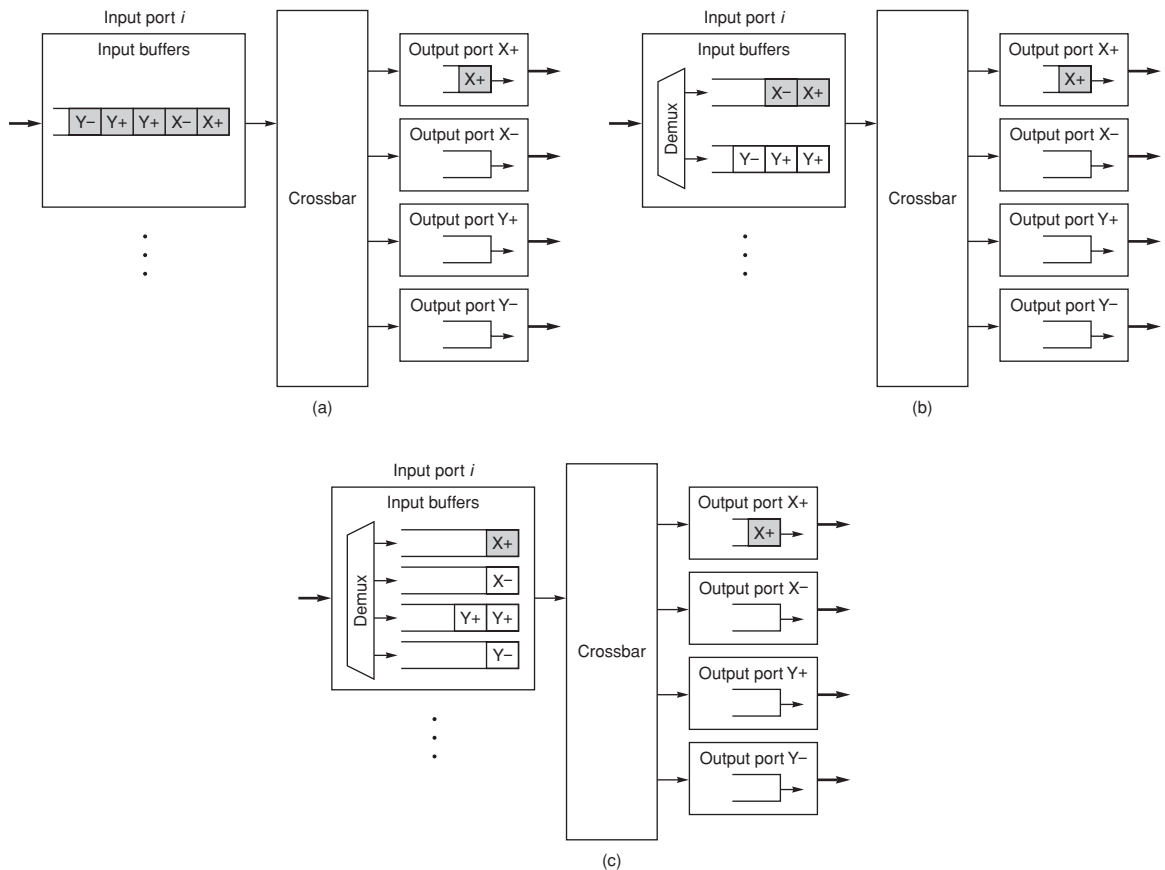

**Figure E.22** (a) Head-of-line blocking in an input buffer, (b) the use of two virtual channels to reduce HOL blocking, and (c) the use of virtual output queuing to eliminate HOL blocking with a switch. The shaded input buffer is the one to which the crossbar is currently allocated. This assumes each input port has only one access port to the switch's internal crossbar.

organize the input queues as *virtual output queues* (VOQs), shown in Figure E.22 (c). With this, each input port implements as many queues as there are output ports, thus providing separate buffers for packets destined to different output ports. This is a popular technique widely used in ATM switches and IP routers. The main drawback of VOQs, however, is cost and lack of scalability: the number of VOQs grows quadratically with switch ports. Moreover, although VOQs eliminate HOL blocking within a switch, HOL blocking occurring at the network level end-to-end is not solved. Of course, it is possible to design a switch with VOQ support at the network level also—that is, to implement as many queues per switch input port as there are output ports across the entire network—but this is extremely expensive. An alternative is to dynamically assign only a fraction of the queues to store (cache) separately only those packets headed for congested destinations.

Combined input-output-buffered switches minimize HOL blocking when there is sufficient buffer space at the output side to buffer packets, and they minimize the switch speedup required due to buffers being at the input side. This solution has the further benefit of decoupling packet transmission through the internal crossbar of the switch from transmission through the external links. This is especially useful for cut-through switching implementations that use virtual channels, where flit transmissions are time-multiplexed over the links. Many designs used in commercial systems implement input-output-buffered switches.

## Pipelining the Switch Microarchitecture

Performance can be enhanced by pipelining the switch microarchitecture. Pipelined processing of packets in a switch has similarities with pipelined execution of instructions in a vector processor. In a vector pipeline, a single instruction indicates what operation to apply to all the vector elements executed in a pipelined way. Similarly, in a switch pipeline, a single packet header indicates how to process all of the internal data path physical transfer units (or *phits*) of a packet, which are processed in a pipelined fashion. Also, as packets at different input ports are independent of each other, they can be processed in parallel similar to the way multiple independent instructions or threads of pipelined instructions can be executed in parallel.

The switch microarchitecture can be pipelined by analyzing the basic functions performed within the switch and organizing them into several stages. Figure E.23 shows a block diagram of a five-stage pipelined organization for the basic switch microarchitecture given in Figure E.21, assuming cut-through switching and the use of a forwarding table to implement routing. After receiving the header portion of the packet in the first stage, the routing information (i.e., destination address) is used in the second stage to look up the allowed routing option(s) in the forwarding table. Concurrent with this, other portions of the packet are received and buffered in the input port queue at the first stage. Arbitration is performed in the third stage. The crossbar is configured to allocate the

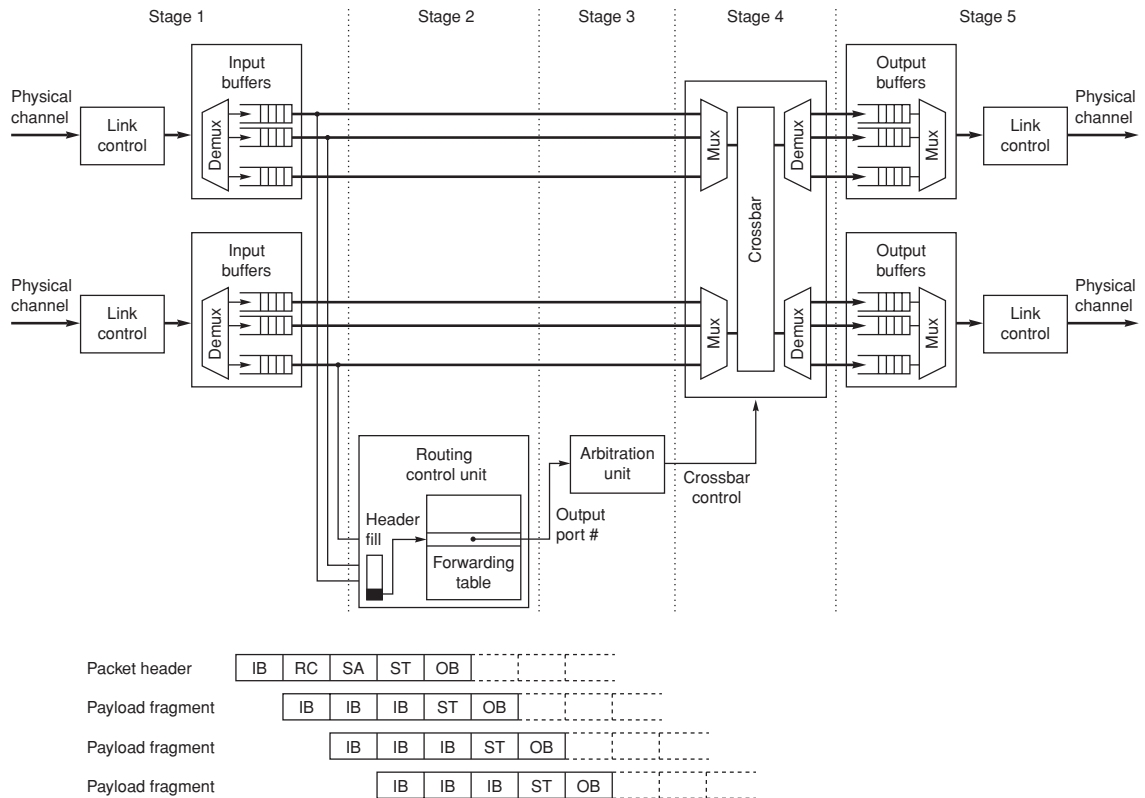

**Figure E.23** Pipelined version of the basic input-output-buffered switch. The notation in the figure is as follows: IB is the input link control and buffer stage, RC is the route computation stage, SA is the crossbar switch arbitration stage, ST is the crossbar switch traversal stage, and OB is the output buffer and link control stage. Packet fragments (flits) coming after the header remain in the IB stage until the header is processed and the crossbar switch resources are provided.

granted output port for the packet in the fourth stage, and the packet header is buffered in the switch output port and ready for transmission over the external link in the fifth stage. Note that the second and third stages are used only by the packet header; the payload and trailer portions of the packet use only three of the stages—those used for data flow-thru once the internal data path of the switch is set up.

A virtual channel switch usually requires an additional stage for virtual channel allocation. Moreover, arbitration is required for every flit before transmission through the crossbar. Finally, depending on the complexity of the routing and arbitration algorithms, several clock cycles may be required for these operations.

## Other Switch Microarchitecture Enhancements

As mentioned earlier, internal switch speedup is sometimes implemented to increase switch output port utilization. This speedup is usually implemented by increasing the clock frequency and/or the internal data path width (i.e., phit size) of the switch. An alternative solution consists of implementing several parallel data paths from each input port's set of queues to the output ports. One way of doing this is by increasing the number of crossbar input ports. In case of implementing several physical queues per input port, this can be achieved by devoting a separate crossbar port to each input queue. For example, the IBM Blue Gene/L implements two crossbar access ports and two read ports per switch input port.

Another way of implementing parallel data paths between input and output ports is to move the buffers to the crossbar crosspoints. This switch architecture is usually referred to as a *buffered crossbar switch*. A buffered crossbar provides independent data paths from each input port to the different output ports, thus making it possible to send up to  $k$  packets at a time from a given input port to  $k$  different output ports. By implementing independent crosspoint memories for each input-output port pair, HOL blocking is eliminated at the switch level. Moreover, arbitration is significantly simpler than in other switch architectures. Effectively, each output port can receive packets from only a disjoint subset of the crosspoint memories. Thus, a completely independent arbiter can be implemented at each switch output port, each of those arbiters being very simple.

A buffered crossbar would be the ideal switch architecture if it were not so expensive. The number of crosspoint memories increases quadratically with the number of switch ports, dramatically increasing its cost and reducing its scalability with respect to the basic switch architecture. In addition, each crosspoint memory must be large enough to efficiently implement link-level flow control. To reduce cost, most designers prefer input-buffered or combined input-output-buffered switches enhanced with some of the mechanisms described previously.

---

### E.7

## Practical Issues for Commercial Interconnection Networks

There are practical issues in addition to the technical issues described thus far that are important considerations for interconnection networks within certain domains. We mention a few of these below.

### Connectivity

The type and number of devices that communicate and their communication requirements affect the complexity of the interconnection network and its protocols. The protocols must target the largest network size and handle the types of anomalous systemwide events that might occur. Among some of the issues are the following: How lightweight should the network interface hardware/software

be? Should it attach to the memory network or the I/O network? Should it support cache coherence? If the operating system must get involved for every network transaction, the sending and receiving overhead becomes quite large. If the network interface attaches to the I/O network (PCI-Express or HyperTransport interconnect), the injection and reception bandwidth will be limited to that of the I/O network. This is the case for the Cray XT3 SeaStar, Intel Thunder Tiger 4 QsNet<sup>II</sup>, and many other supercomputer and cluster networks. To support coherence, the sender may have to flush the cache before each send, and the receiver may have to flush its cache before each receive to prevent the stale-data problem. Such flushes further increase sending and receiving overhead, often causing the network interface to be the network bottleneck.

Computer systems typically have a multiplicity of interconnects with different functions and cost-performance objectives. For example, processor-memory interconnects usually provide higher bandwidth and lower latency than I/O interconnects and are more likely to support cache coherence, but they are less likely to follow or become standards. The personal computer in 2006 had a processor-memory interconnect and an I/O interconnect (e.g., PCI-X 2.0, PCIe or HyperTransport) designed to connect both fast and slow devices (e.g., USB 2.0, Gigabit Ethernet LAN, Firewire 800, etc.). The Blue Gene/L supercomputer uses five interconnection networks, only one of which is the 3D torus used for most of the interprocessor application traffic. The others include a tree-based collective communication network for broadcast and multicast; a tree-based barrier network for combining results (scatter, gather); a control network for diagnostics, debugging, and initialization; and a Gigabit Ethernet network for I/O between the nodes and disk. The University of Texas at Austin's TRIPS Edge processor has eight specialized on-chip networks—some with bidirectional channels as wide as 128 bits and some with 168 bits in each direction—to interconnect the 106 heterogeneous tiles composing the two processor cores with L2 on-chip cache. It also has a chip-to-chip switched network to interconnect multiple chips in a multiprocessor configuration. Two of the on-chip networks are switched networks: one is used for operand transport and the other is used for on-chip memory communication. The others are essentially fan-out trees or recombination dedicated link networks used for status and control. The portion of chip area allocated to the interconnect is substantial, with five of the seven metal layers used for global network wiring.

### **Standardization: Cross-Company Interoperability**

Standards are useful in many places in computer design, including interconnection networks. Advantages of successful standards include low cost and stability. The customer has many vendors to choose from, which keeps price close to cost due to competition. It makes the viability of the interconnection independent of the stability of a single company. Components designed for a standard interconnection may also have a larger market, and this higher volume can reduce the vendors' costs, further benefiting the customer. Finally, a standard allows many companies to build products with interfaces to the standard, so the customer does



not have to wait for a single company to develop interfaces to all the products of interest.

One drawback of standards is the time it takes for committees and special-interest groups to agree on the definition of standards, which is a problem when technology is changing rapidly. Another problem is *when* to standardize: on the one hand, designers would like to have a standard before anything is built; on the other hand, it would be better if something were built before standardization to avoid legislating useless features or omitting important ones. When done too early, it is often done entirely by committee, which is like asking all of the chefs in France to prepare a single dish of food—masterpieces are rarely served. Standards can also suppress innovation at that level, since standards fix the interfaces—at least until the next version of the standards surface, which can be every few years or longer. More often, we are seeing consortiums of companies getting together to define and agree on technology that serve as “de facto” industry standards. This was the case for InfiniBand.

LANs and WANs use standards and interoperate effectively. WANs involve many types of companies and must connect to many brands of computers, so it is difficult to imagine a proprietary WAN ever being successful. The ubiquitous nature of the Ethernet shows the popularity of standards for LANs as well as WANs, and it seems unlikely that many customers would tie the viability of their LAN to the stability of a single company. Some SANs are standardized such as Fibre Channel, but most are proprietary. OCNs for the most part are proprietary designs, with a few gaining widespread commercial use in system-on-chip (SoC) applications, such as IBM’s CoreConnect and ARM’s AMBA.

## **Congestion Management**

Congestion arises when too many packets try to use the same link or set of links. This leads to a situation in which the bandwidth required exceeds the bandwidth supplied. Congestion by itself does not degrade network performance: simply, the congested links are running at their maximum capacity. Performance degradation occurs in the presence of HOL blocking where, as a consequence of packets going to noncongested destinations getting blocked by packets going to congested destinations, some link bandwidth is wasted and network throughput drops, as illustrated in the example given at the end of Section E.4. *Congestion control* refers to schemes that reduce traffic when the collective traffic of all nodes is too large for the network to handle.

One advantage of a circuit-switched network is that once a circuit is established, it ensures there is sufficient bandwidth to deliver all the information sent along that circuit. Interconnection bandwidth is reserved as circuits are established, and if the network is full, no more circuits can be established. Other switching techniques generally do not reserve interconnect bandwidth in advance, so the interconnection network can become clogged with too many packets. Just as with poor rush-hour commuters, a traffic jam of packets increases packet latency, and in extreme cases, fewer packets per second get delivered by

the interconnect. In order to handle congestion in packet-switched networks, some form of *congestion management* must be implemented. The two kinds of mechanisms used are those that control congestion and those that eliminate the performance degradation introduced by congestion.

There are three basic schemes used for congestion control in interconnection networks, each with its own weaknesses: packet discarding, flow control, and choke packets. The simplest scheme is *packet discarding*, which we discussed briefly in Section E.2. If a packet arrives at a switch and there is no room in the buffer, the packet is discarded. This scheme relies on higher-level software that handles errors in transmission to resend lost packets. This leads to significant bandwidth wastage due to (re)transmitted packets that are later discarded and, therefore, is typically used only in lossy networks like the Internet.

The second scheme relies on *flow control*, also discussed previously. When buffers become full, link-level flow control provides feedback that prevents the transmission of additional packets. This *backpressure* feedback rapidly propagates backward until it reaches the sender(s) of the packets producing congestion, forcing a reduction in the injection rate of packets into the network. The main drawbacks of this scheme are that sources become aware of congestion too late when the network is already congested, and nothing is done to alleviate congestion. Backpressure flow control is common in lossless networks like SANs used in supercomputers and enterprise systems.

A more elaborate way of using flow control is by implementing it directly between the sender and the receiver end nodes, generically called *end-to-end flow control*. *Windowing* is one version of end-to-end credit-based flow control where the window size should be large enough to efficiently pipeline packets through the network. The goal of the window is to limit the number of unacknowledged packets, thus bounding the contribution of each source to congestion, should it arise. The TCP protocol uses a sliding window. Note that end-to-end flow control describes the interaction between just two nodes of the interconnection network, not the entire interconnection network between all end nodes. Hence, flow control helps congestion control, but it is not a global solution.

*Choke packets* are used in the third scheme, which is built upon the premise that traffic injection should be throttled only when congestion exists across the network. The idea is for each switch to see how busy it is and to enter into a warning state when it passes a threshold. Each packet received by a switch in the warning state is sent back to the source via a choke packet that includes the intended destination. The source is expected to reduce traffic to that destination by a fixed percentage. Since it likely will have already sent other packets along that path, the source node waits for all the packets in transit to be returned before acting on the choke packets. In this scheme, congestion is controlled by reducing the packet injection rate until traffic reduces, just as metering lights that guard on-ramps control the rate of cars entering a freeway. This scheme works efficiently when the feedback delay is short. When congestion notification takes a long time, usually due to long time of flight, this congestion control scheme may become unstable—reacting too slowly or producing oscillations in packet injection rate, both of which lead to poor network bandwidth utilization.

An alternative to congestion control consists of eliminating the negative consequences of congestion. This can be done by eliminating HOL blocking at every switch in the network as discussed previously. Virtual output queues can be used for this purpose. However, it would be necessary to implement as many queues at every switch input port as devices attached to the network. This solution is very expensive, and not scalable at all. Fortunately, it is possible to achieve good results by dynamically assigning a few set-aside queues to store only the congested packets that travel through some hot-spot regions of the network, very much like caches are intended to store only the more frequently accessed memory locations. This strategy is referred to as *regional explicit congestion notification* (RECN).

## Fault Tolerance

The probability of system failures increases as transistor integration density and the number of devices in the system increases. Consequently, system reliability and availability have become major concerns and will be even more important in future systems with the proliferation of interconnected devices. A practical issue arises, therefore, as to whether or not the interconnection network relies on all the devices being operational in order for the network to work properly. Since software failures are generally much more frequent than hardware failures, another question surfaces as to whether a software crash on a single device can prevent the rest of the devices from communicating. Although some hardware designers try to build fault-free networks, in practice it is only a question of the rate of failures, not whether they can be prevented. Thus, the communication subsystem must have mechanisms for dealing with faults when—not if—they occur.

There are two main kinds of failure in an interconnection network: *transient* and *permanent*. Transient failures are usually produced by electromagnetic interference and can be detected and corrected using the techniques described in Section E.2. Oftentimes, these can be dealt with simply by retransmitting the packet either at the link level or end-to-end. Permanent failures occur when some component stops working within specifications. Typically, these are produced by overheating, overbiasing, overuse, aging, and so on, and cannot be recovered from simply by retransmitting packets with the help of some higher-layer software protocol. Either an alternative physical path must exist in the network and be supplied by the routing algorithm to circumvent the fault or the network will be crippled, unable to deliver packets whose only paths are through faulty resources.

Three major categories of techniques are used to deal with permanent failures: *resource sparing*, *fault-tolerant routing*, and *network reconfiguration*. In the first technique, faulty resources are switched off or bypassed, and some spare resources are switched in to replace the faulty ones. As an example, the Server-Net interconnection network is designed with two identical switch fabrics, only one of which is usable at any given time. In case of failure in one fabric, the other is used. This technique can also be implemented without switching in spare resources, leading to a degraded mode of operation after a failure. The IBM Blue

Gene/L supercomputer, for instance, has the facility to bypass failed network resources while retaining its base topological structure and routing algorithm. The main drawback of this technique is the relatively large number of healthy resources (i.e., midplane node boards) that may need to be switched off after a failure in order to retain the base topological structure (i.e., a 3D torus).

Fault-tolerant routing, on the other hand, takes advantage of the multiple paths already existing in the network topology to route messages in the presence of failures without requiring spare resources. Alternative paths for each supported fault combination are identified at design time and incorporated into the routing algorithm. When a fault is detected, a suitable alternative path is used. The main difficulty when using this technique is guaranteeing that the routing algorithm will remain deadlock-free when using the alternative paths, given that arbitrary fault patterns may occur. This is especially difficult in direct networks whose regularity can be compromised by the fault pattern. The Cray T3E is an example system that successfully applies this technique on its 3D torus direct network. There are many examples of this technique in systems using indirect networks, such as with the bidirectional multistage networks in the ASCI White and ASC Purple. Those networks provide multiple minimal paths between end nodes and, inherently, have no routing deadlock problems (see Section E.5). In these networks, alternative paths are selected at the source node in case of failure.

Network reconfiguration is yet another, more general technique to handle voluntary and involuntary changes in the network topology due either to failures or to some other cause. In order for the network to be reconfigured, the nonfaulty portions of the topology must first be discovered, followed by computation of the new routing tables and distribution of the routing tables to the corresponding network locations (i.e., switches and/or end node devices). Network reconfiguration requires the use of programmable switches and/or network interfaces, depending on how routing is performed. It may also make use of generic routing algorithms (e.g., up\*/down\* routing) that can be configured for all the possible network topologies that may result after faults. This strategy relieves the designer from having to supply alternative paths for each possible fault combination at design time. Programmable network components provide a high degree of flexibility but at the expense of higher cost and latency. Most standard and proprietary interconnection networks for clusters and SANs—including Myrinet, Quadrics, InfiniBand, Advanced Switching, and Fibre Channel—incorporate software for (re)configuring the network routing in accordance with the prevailing topology.

Another practical issue ties to node failure tolerance. If an interconnection network can survive a failure, can it also continue operation while a new node is added to or removed from the network, usually referred to as *hot swapping*? If not, each addition or removal of a new node disables the interconnection network, which is impractical for WANs and LANs, and is usually intolerable for most SANs. Online system expansion requires hot swapping, so most networks allow for it. Hot swapping is usually supported by implementing *dynamic network reconfiguration*, in which the network is reconfigured without having to stop user traffic. The main difficulty with this is guaranteeing deadlock-free routing while routing tables for switches and/or end node devices are dynamically

and asynchronously updated as more than one routing algorithm may be alive (and, perhaps, clashing) in the network at the same time. Most WANs solve this problem by dropping packets whenever required, but dynamic network reconfiguration is much more complex in lossless networks. Several theories and practical techniques have recently been developed to address this problem efficiently.

---

**Example** Figure E.24 shows the number of failures of 58 desktop computers on a local area network for a period of just over one year. Suppose that one local area network is based on a network that requires all machines to be operational for the interconnection network to send data; if a node crashes, it cannot accept messages, so the interconnection becomes choked with data waiting to be delivered. An alternative is the traditional local area network, which can operate in the presence of node failures; the interconnection simply discards messages for a node that decides not to accept them. Assuming that you need to have both your workstation and the connecting LAN to get your work done, how much greater are your chances of being prevented from getting your work done using the failure-intolerant LAN versus traditional LANs? Assume the downtime for a crash is less than 30 minutes. Calculate using the one-hour intervals from this figure.

**Answer** Assuming the numbers for Figure E.24, the percentage of hours that you can't get your work done using the failure-intolerant network is

$$\begin{aligned} \frac{\text{Intervals with failures}}{\text{Total intervals}} &= \frac{\text{Total intervals} - \text{Intervals with no failures}}{\text{Total intervals}} \\ &= \frac{8974 - 8605}{8974} = \frac{369}{8974} = 4.1\% \end{aligned}$$

The percentage of hours that you can't get your work done using the traditional network is just the time your workstation has crashed. If these failures are equally distributed among workstations, the percentage is

$$\frac{\text{Failures/Machines}}{\text{Total intervals}} = \frac{654/58}{8974} = \frac{11.28}{8974} = 0.13\%$$

Hence, you are more than 30 times more likely to be prevented from getting your work done with the failure-intolerant LAN than with the traditional LAN, according to the failure statistics in Figure E.24. Stated alternatively, the person responsible for maintaining the LAN would receive a 30-fold increase in phone calls from irate users!

---

Failed machines per time interval	One-hour intervals with number of failed machines in first column	Total failures per one-hour interval	One-day intervals with number of failed machines in first column	Total failures per one-day interval
0	8605	0	184	0
1	264	264	105	105
2	50	100	35	70
3	25	75	11	33
4	10	40	6	24
5	7	35	9	45
6	3	18	6	36
7	1	7	4	28
8	1	8	4	32
9	2	18	2	18
10	2	20		
11	1	11	2	22
12			1	12
17	1	17		
20	1	20		
21	1	21	1	21
31			1	31
38			1	38
58			1	58
<b>Total</b>	<b>8974</b>	<b>654</b>	<b>373</b>	<b>573</b>

**Figure E.24** Measurement of reboots of 58 DECstation 5000s running Ultrix over a 373-day period. These reboots are distributed into time intervals of one hour and one day. The first column sorts the intervals according to the number of machines that failed in that interval. The next two columns concern one-hour intervals, and the last two columns concern one-day intervals. The second and fourth columns show the number of intervals for each number of failed machines. The third and fifth columns are just the product of the number of failed machines and the number of intervals. For example, there were 50 occurrences of one-hour intervals with 2 failed machines, for a total of 100 failed machines, and there were 35 days with 2 failed machines, for a total of 70 failures. As we would expect, the number of failures per interval changes with the size of the interval. For example, the day with 31 failures might include one hour with 11 failures and one hour with 20 failures. The last row shows the total number of each column; the number of failures doesn't agree because multiple reboots of the same machine in the same interval do not result in separate entries. (Randy Wang of U.C. Berkeley collected these data.)

## E.8

**Examples of Interconnection Networks**

To further provide mass to the concepts described in the previous sections, we look at five example networks from the four interconnection network domains considered in this appendix. In addition to one for each of the OCN, LAN, and WAN areas, we look at two examples from the SAN area: one for system area networks and one for system/storage area networks. The first two examples are proprietary networks used in high-performance systems; the latter three examples are network standards widely used in commercial systems.

**On-Chip Network: Cell Broadband Engine's Element Interconnect**

With continued increases in transistor integration as predicted by Moore's Law, processor designers are under the gun to find ways of combating chip-crossing wire delay and other problems associated with deep submicron technology scaling. *Multicore* microarchitectures are gaining popularity, given their advantages of simplicity, modularity, and ability to exploit parallelism beyond that which can be achieved through aggressive pipelining and multiple instruction/data issuing on a single core. No matter whether the processor consists of a single core or multiple cores, higher and higher demands are being placed on intrachip communication bandwidth to keep pace—not to mention interchip bandwidth. This has spurred a great amount of interest in OCN designs that efficiently support communication of instructions, register operands, memory, and I/O data within and between processor cores both on and off the chip. Here we focus on one such on-chip network: the Cell Broadband Engine's Element Interconnect Bus.

The Cell Broadband Engine (Cell BE) is a heterogeneous multicore processor designed for high performance on multimedia and game applications requiring real-time responsiveness to users. Development of the processor started in 2000 by Sony, IBM, and Toshiba, with the first products shipped in 2005. The 200 GFLOPS (peak) Cell BE chip incorporates a 64-bit Power processor element (PPE), eight 128-bit SIMD synergistic processor elements (SPEs) with local store, a memory interface controller (MIC) element, and two configurable I/O interface elements—one of which supports a coherent protocol. Using the coherent I/O interface configurable to 20 GB/sec bandwidth, up to two Cell BEs can be directly connected or up to four Cell BEs can be assembled into a four-way symmetric multiprocessor system via an external switch. Figure E.25 shows a die photo and high-level block diagram of the Cell BE.

The 12 elements within the Cell BE are interconnected over a 235 mm<sup>2</sup> chip area with a proprietary on-chip network: the Element Interconnect Bus (EIB). The data portion of the EIB consists of four separate but identical alternating unidirectional rings, two in each direction interleaved with power and ground to reduce coupling noise. Each ring interconnecting the 12 nodes operates more like a dynamically segmentable shared bus than a point-to-point switched network. All data links comprising the rings are 128 bits wide and are clocked at 1.6 GHz



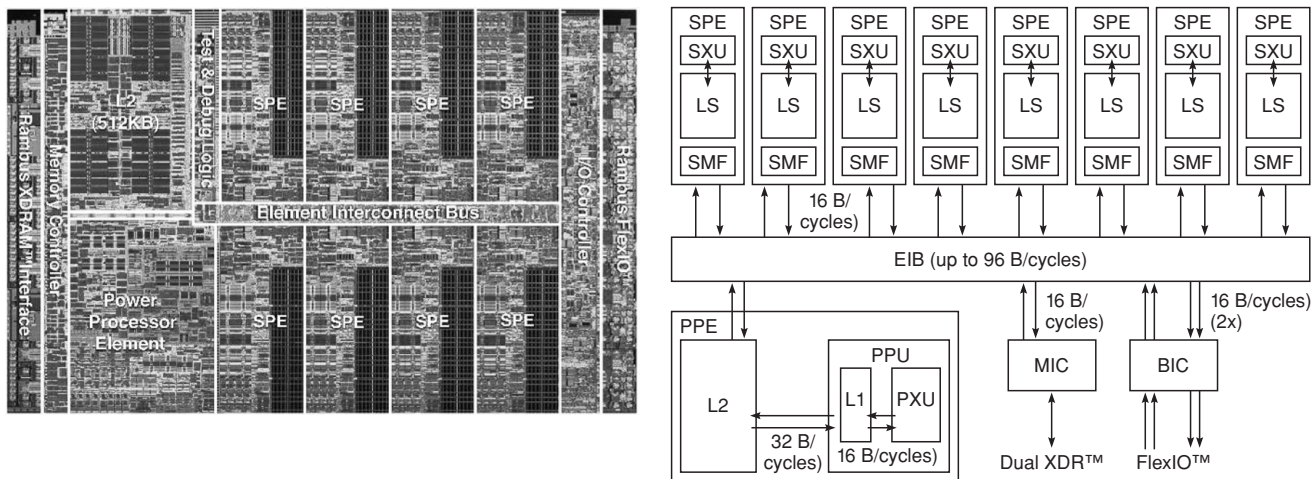

**Figure E.25** Cell Broadband Engine (a) die photo and (b) high-level block diagram illustrating the function of the EIB. © IBM Corporation, 2005. All rights reserved.

(half the processor clock rate) to provide a data bandwidth of 25.6 GB/sec, including injection and reception links. These links occupy two of the eight metal layers of the 1236-pin chip, where most of the chip pin-outs are used for power and ground, leaving approximately 506 for signal pins.

Each SPE has a synergistic memory flow control unit that acts as a DMA engine, allowing up to 16 outstanding data transfers. Packets range in size from 16 bytes to a maximum of 128 bytes, where 2 bytes of tag control on separate control lines accompany each ring data transmission. Packets have no headers. Routing paths are preestablished ahead of time during a separate EIB arbitration and routing phase. Pipelined circuit switching is used once paths are established, where each ring switch has room to store only one 16-byte phit. No error detection or correction is supported on the EIB.

Credit-based flow control is used to manage the allocation of resources, including the EIB. Requestors first gain permission (in the form of receiving tokens or credits) from a central token manager to use the EIB and then issue a set of commands to ensure a coherent cache/memory state before arbitrating for the EIB to do a coherent read or write data transfer. The coherence actions are needed to make the ring topology transparent to the element data interface. They can take over 40 network cycles but are done on separate address concentrator control networks, each implemented in a treelike structure. This minimizes the wiring resources, distributes the control, and allows data transfers on the EIB to occur concurrently with command transfers. A two-stage, dual round-robin centralized network arbiter is used to grant access to one of the EIB rings, taking into account end-to-end as well as link-level ring contention. The MIC has the highest priority in order to prevent stalling on data reads from memory; all other requests have lower priority. The same arbiter is also used to set up pipelined circuit-switched routes (a minimal path) from source elements to destination elements



across the selected ring. One grant per ring can be issued by the arbiter every 3 cycles, and up to three nonconflicting data transfers can occur over each ring, allowing a maximum of 12 outstanding data transfers across all four EIB rings.

The latency through each hop is 1 network cycle, but the transmission time for the largest-sized packet is 8 cycles. The peak instantaneous EIB effective bandwidth is 307.2 GB/sec, and the best-case sustainable EIB effective bandwidth is 204.8 GB/sec (i.e., two nonconflicting data transfers per ring). This is limited by the maximum command throughput in the command tree, not the data arbiter. The EIB effective bandwidth is further reduced when there are conflicting data transfers on each ring between SPEs and also when the MIC serves as a reception link bottlenecking point (i.e., when multiple SPEs try to access the MIC, which operates at only 25.6 GB/sec). Finally, although eight SPEs are implemented, one is used for resource sparing, allowing only seven to be used at any one time.

By way of comparison, Figure E.26 shows some on-chip network characteristics of the Cell BE EIB, along with a few other on-chip networks implemented in recent research and commercial multicore processors.

### **System Area Network: IBM Blue Gene/L 3D Torus Network**

The IBM BlueGene/L was the largest-scaled, highest-performing computer system in the world in 2005, according to *www.top500.org*. With 65,536 dual-processor compute nodes and 1024 I/O nodes, this 360 TFLOPS (peak) supercomputer has a system footprint of approximately 2500 square feet. Both processors at each node can be used for computation and can handle their own communication protocol processing in virtual mode or, alternatively, one of the processors can be used for computation and the other for network interface processing. Packets range in size from 32 bytes to a maximum of 256 bytes, and 8 bytes are used for the header. The header includes routing, virtual channel, link-level flow control, packet size, and other such information, along with 1 byte for CRC to protect the header. Three bytes are used for CRC at the packet level, and 1 byte serves as a valid indicator.

The main interconnection network is a proprietary  $32 \times 32 \times 64$  3D torus SAN that interconnects all 64K nodes. Each node switch has six 350 MB/sec bidirectional links to neighboring torus nodes, an injection bandwidth of 612.5 MB/sec from the two node processors, and a reception bandwidth of 1050 MB/sec to the two node processors. The reception bandwidth from the network equals the inbound bandwidth across all switch ports, which prevents reception links from bottlenecking network performance. Multiple packets can be sunk concurrently at each destination node because of the higher reception link bandwidth.

Two nodes are implemented on a  $2 \times 1 \times 1$  compute card, 16 compute cards and two I/O cards are implemented on a  $4 \times 4 \times 2$  node board, 16 node boards are implemented on an  $8 \times 8 \times 8$  midplane, and 2 midplanes form a 1024 node rack with physical dimensions of  $0.9 \times 0.9 \times 1.9$  cubic meters. Links have a maximum physical length of 8.6 meters, thus enabling efficient link-level flow control with

Institution and processor [network] name	Year built	Number of network ports [cores or tiles + other ports]	Basic network topology	# of data bits per link per direction	Link bandwidth [link clock speed]	Routing; arbitration; switching	# of chip metal layers; flow control; # virtual channels
MIT Raw [General Dynamic Network]	2002	16 ports [16 tiles]	2D mesh $4 \times 4$	32 bits	0.9 GB/sec [225 MHz, clocked at proc speed]	XY DOR with request-reply deadlock recovery; RR arbitration; wormhole	6 layers; credit-based; no virtual channels
IBM Power5	2004	7 ports [2 PE cores + 5 other ports]	crossbar	256 bits Inst fetch; 64 bits for stores; 256 bits LDs	[1.9 GHz, clocked at proc speed]	shortest-path; nonblocking; circuit switch	7 layers; handshaking; no virtual channels
U.T. Austin TRIP Edge [Operand Network]	2005	25 ports [25 execution unit tiles]	2D mesh $5 \times 5$	110 bits	5.86 GB/sec [533 MHz clock scaled by 80%]	YX DOR; distributed RR arbitration; wormhole	7 layers; on/off flow control; no virtual channels
U.T. Austin TRIP Edge [On-Chip Network]	2005	40 ports [16 L2 tiles + 24 network interface tile]	2D mesh $10 \times 4$	128 bits	6.8 GB/sec [533 MHz clock scaled by 80%]	YX DOR; distributed RR arbitration; VCT switched	7 layers; credit-based flow control; 4 virtual channels
Sony, IBM, Toshiba Cell BE [Element Interconnect Bus]	2005	12 ports [1 PPE and 8 SPEs + 3 other ports for memory, I/O interface]	ring 4 total, 2 in each direction	128 bits data (+ 16 bits tag)	25.6 GB/sec [1.6 GHz, clocked at half the proc speed]	shortest-path; tree-based RR arbitration (centralized); pipelined circuit switch	8 layers; credit-based flow control; no virtual channels
Sun UltraSPARC T1 processor	2005	up to 13 ports [8 PE cores + 4 L2 banks + 1 shared I/O]	crossbar	128 bits both for the 8 cores and the 4 L2 banks	19.2 GB/sec [1.2 GHz, clocked at proc speed]	shortest-path; age-based arbitration; VCT switched	9 layers; handshaking; no virtual channels

**Figure E.26** Characteristics of on-chip networks implemented in recent research and commercial processors. Some processors implement multiple on-chip networks (not all shown)—for example, two in the MIT Raw and eight in the TRIP Edge.

reasonably low buffering requirements. Low latency is achieved by implementing virtual cut-through switching, distributing arbitration at switch input and output ports, and precomputing the current routing path at the previous switch using a finite-state machine so that part of the routing delay is removed from the critical path in switches. High effective bandwidth is achieved using input-buffered switches with dual read ports, virtual cut-through switching with four virtual channels, and fully adaptive deadlock-free routing based on bubble flow control.

A key feature in networks of this size is fault tolerance. Failure rate is reduced by using a relatively low link clock frequency of 700 MHz (same as processor clock) on which both edges of the clock are used (i.e., 1.4 Gbps or 175 MB/sec transfer rate is supported for each bit-serial network link in each direction), but failures may still occur in the network. In case of failure, the midplane node boards containing the fault(s) are switched off and bypassed to isolate the fault, and computation resumes from the last checkpoint. Bypassing is done using separate bypass switch boards associated with each midplane that are additional to the set of torus node boards. Each bypass switch board can be configured to connect either to the corresponding links in the midplane node boards or to the next bypass board, effectively removing the corresponding set of midplane node boards. Although the number of processing nodes is reduced to some degree in some network dimensions, the machine retains its topological structure and routing algorithm.

Some collective communication operations such as barrier synchronization, broadcast/multicast, reduction, and so on, are not performed well on the 3D torus as the network would be flooded with traffic. To remedy this, two separate tree networks with higher per-link bandwidth are used to implement collective and combining operations more efficiently. In addition to providing support for efficient synchronization and broadcast/multicast, hardware is used to perform some arithmetic reduction operations in an efficient way (e.g., to compute the sum or the maximum value of a set of values, one from each processing node). In addition to the 3D torus and the two tree networks, the Blue Gene/L implements an I/O Gigabit Ethernet network and a control system Fast Ethernet network of lower bandwidth to provide for parallel I/O, configuration, debugging, and maintenance.

### **System/Storage Area Network: InfiniBand**

InfiniBand is an industrywide de facto networking standard developed by a consortium of companies belonging to the InfiniBand Trade Association in October 2000. InfiniBand can be used as a system area network for interprocessor communication or as a storage area network for server I/O. It is a switch-based interconnect technology that provides flexibility in the topology, routing algorithm, and arbitration technique implemented by vendors and users. InfiniBand supports data transmission rates of 2–120 Gbp/link per direction across distances of 300 m. It uses cut-through switching, 16 virtual channels and service levels, credit-based link-level flow control, and weighted round-robin fair scheduling and implements programmable forwarding tables. It also includes features useful for increasing reliability and system availability, such as communication subnet management, end-to-end path establishment, and virtual destination naming. Figure E.27 shows the packet format for InfiniBand juxtaposed to two other network standards from the LAN and WAN areas. Figure E.28 compares various characteristics of the InfiniBand standard with two proprietary system area networks widely used in research and commercial high-performance computer systems.

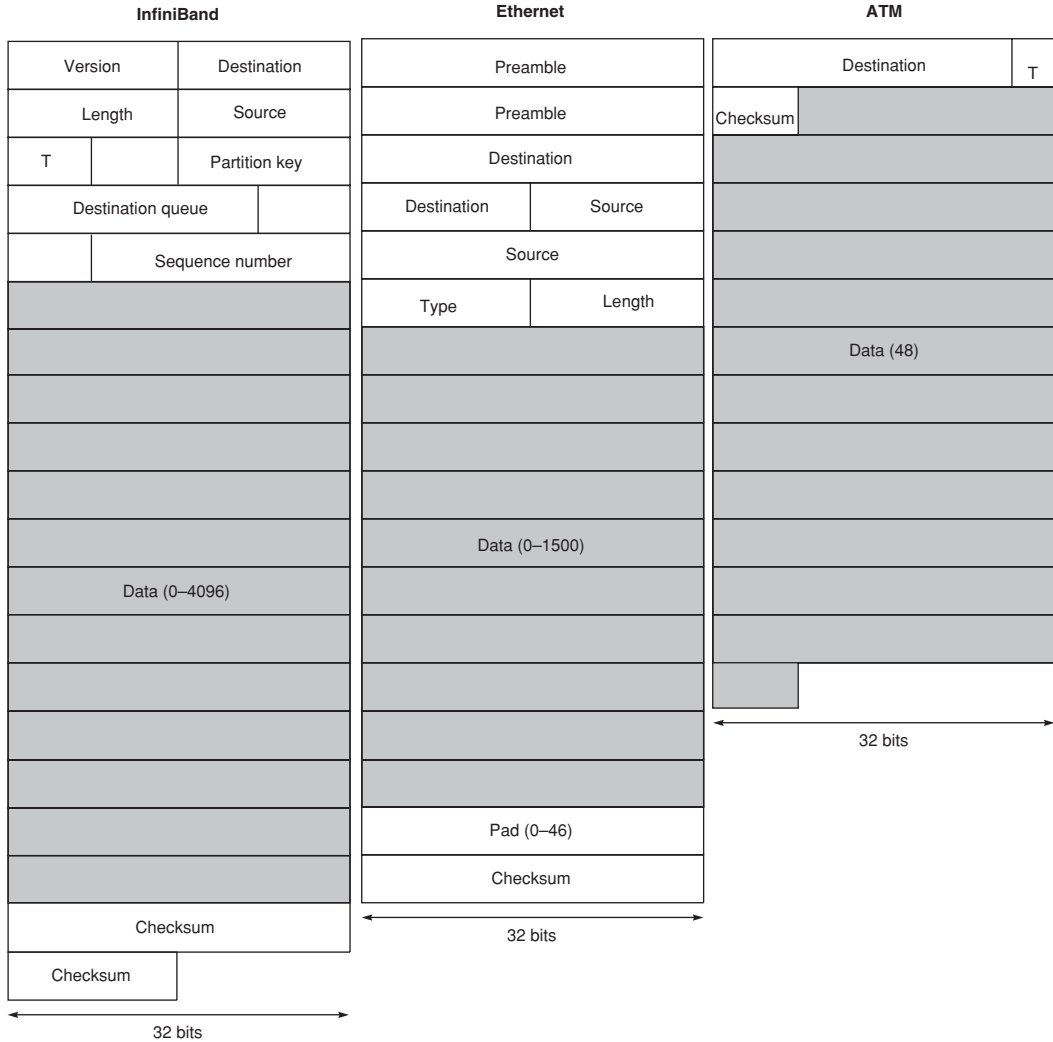

**Figure E.27 Packet format for InfiniBand, Ethernet, and ATM.** ATM calls their messages “cells” instead of packets, so the proper name is ATM cell format. The width of each drawing is 32 bits. All three formats have destination addressing fields, encoded differently for each situation. All three also have a checksum field to catch transmission errors, although the ATM checksum field is calculated only over the header; ATM relies on higher-level protocols to catch errors in the data. Both InfiniBand and Ethernet have a length field, since the packets hold a variable amount of data, with the former counted in 32-bit words and the latter in bytes. InfiniBand and ATM headers have a type field (T) that gives the type of packet. The remaining Ethernet fields are a preamble to allow the receiver to recover the clock from the self-clocking code used on the Ethernet, the source address, and a pad field to make sure the smallest packet is 64 bytes (including the header). InfiniBand includes a version field for protocol version, a sequence number to allow in-order delivery, a field to select the destination queue, and a partition key field. Infiniband has many more small fields not shown and many other packet formats; above is a simplified view. ATM’s short, fixed packet is a good match to real-time demand of digital voice.

Network name [vendors]	Used in top 10 supercomputer clusters (2005)	Number of nodes	Basic network topology	Raw link bidirectional BW	Routing algorithm	Arbitration technique	Switching technique; flow control
InfiniBand [Mellanox, Voltair]	SGI Altrix and Dell Poweredge Thunderbird	> millions (2 <sup>128</sup> GUID addresses, like IPv6)	completely configurable (arbitrary)	4–240 Gbps	arbitrary (table-driven), typically up*/down*	weighted RR fair scheduling (2-level priority)	cut-through, 16 virtual channels (15 for data); credit-based
Myrinet-2000 [Myricom]	Barcelona Supercomputer Center in Spain	8192 nodes	bidirectional MIN with 16-port bidirectional switches (Clos net.)	4 Gbps	source-based dispersive (adaptive) minimal routing	round-robin arbitration	cut-through switching with no virtual channels; Xon/Xoff flow control
QsNet <sup>II</sup> [Quadrics]	Intel Thunder Itanium2 Tiger4	> tens of thousands	fat tree with 8-port bidirectional switches	21.3 Gbps	source-based LCA adaptive shortest-path routing	2-phased RR, priority, aging, distributed at output ports	wormhole with 2 virtual channels; credit-based

**Figure E.28** Characteristics of system area networks implemented in various top 10 supercomputer clusters in 2005.

InfiniBand offers two basic mechanisms to support user-level communication: send/receive and remote DMA (RDMA). With send/receive, the receiver has to explicitly post a receive buffer (i.e., allocate space in its channel adapter network interface) before the sender can transmit data. With RDMA, the sender can remotely DMA data directly into the receiver device’s memory. For example, for a nominal packet size of 4 bytes measured on a Mellanox MHEA28-XT channel adapter connected to a 3.4 GHz Intel Xeon host device, sending and receiving overhead is 0.946 and 1.423  $\mu$ s, respectively, for the send/receive mechanism, whereas it is 0.910 and 0.323  $\mu$ s, respectively, for the RDMA mechanism.

As discussed in Section E.2, the packet size is important in getting full benefit of the network bandwidth. One might ask, “What is the natural size of messages?” Figure E.29 (a) shows the size of messages for a commercial fluid dynamics simulation application, called Fluent, collected on an InfiniBand network at The Ohio State University’s Network-Based Computer Laboratory. One plot is cumulative in messages sent and the other is cumulative in data bytes sent. Messages in this graph are message passing interface (MPI) units of information, which gets divided into InfiniBand maximum transfer units (packets) transferred over the network. As shown, the maximum message size is over 512 KB, but approximately 90% of the messages are less than 512 bytes. Messages of 2 KB represent approximately 50% of the bytes transferred. An Integer Sort application kernel in the NAS Parallel Benchmark suite is also measured to have about 75% of its messages below 512 bytes (plots not shown). Many applications send far more small messages than large ones, particularly since requests and acknowledgments are more frequent than data responses and block writes.

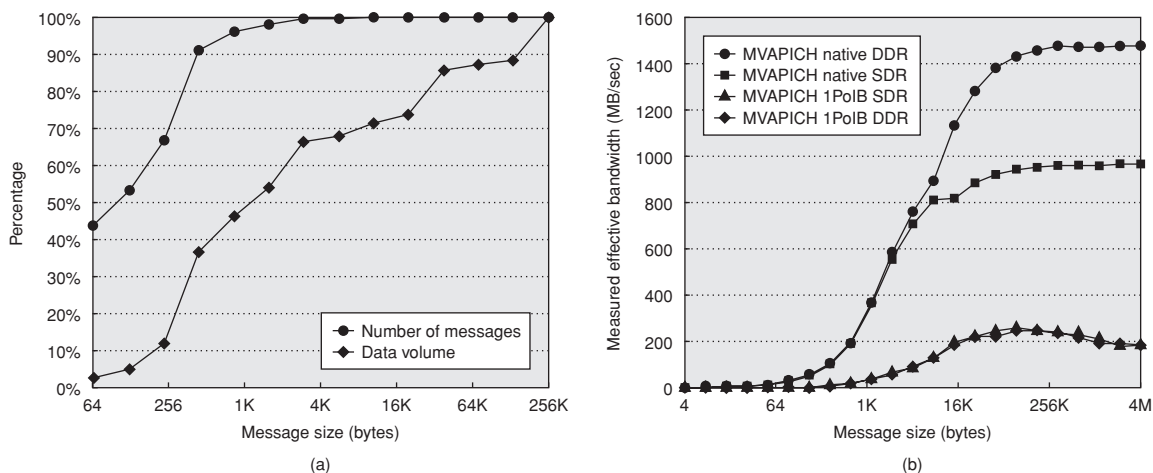

**Figure E.29** Data collected by D.K. Panda, S. Sur, and L. Chai (2005) in the Network-Based Computing Laboratory at The Ohio State University. (a) Cumulative percentage of messages and volume of data transferred as message size varies for the Fluent application ([www.fluent.com](http://www.fluent.com)). Each x-axis entry includes all bytes up to the next one; for example, 128 represents 1 byte to 128 bytes. About 90% of the messages are less than 512 bytes, which represents about 40% of the total bytes transferred. (b) Effective bandwidth versus message size measured on SDR and DDR InfiniBand networks running MVAPICH (<http://nowlab.cse.ohio-state.edu/projects/mpi-iba>) with OS bypass (native) and without (IPoB).

InfiniBand reduces protocol processing overhead by allowing it to be offloaded from the host computer to a controller on the InfiniBand network interface card. The benefits of protocol offloading and bypassing the operating system are shown in Figure E.29 (b) for MVAPICH, a widely used implementation of MPI over InfiniBand. Effective bandwidth is plotted against message size for MVAPICH configured in two modes and two network speeds. One mode runs IPoB, in which InfiniBand communication is handled by the IP layer implemented by the host's operating system (i.e., no OS bypass). The other mode runs MVAPICH directly over VAPI, which is the native Mellanox InfiniBand interface that offloads transport protocol processing to the channel adapter hardware (i.e., OS bypass). Results are shown for 10 Gbps single data rate (SDR) and 20 Gbps double data rate (DDR) InfiniBand networks. The results clearly show that offloading the protocol processing and bypassing the OS significantly reduce sending and receiving overhead to allow near wire-speed effective bandwidth to be achieved.

## Ethernet: *The Local Area Network*

Ethernet has been extraordinarily successful as a LAN—from the 10 Mbit/sec standard proposed in 1978 used practically everywhere today to the more recent 10 Gbit/sec standard that will likely be widely used. Many classes of computers include Ethernet as a standard communication interface. Ethernet, codified as IEEE standard 802.3, is a packet-switched network that routes packets using the

destination address. It was originally designed for coaxial cable but today uses primarily Cat5E copper wire, with optical fiber reserved for longer distances and higher bandwidths. There is even a wireless version (802.11), which is testimony to its ubiquity.

Over a 20-year span, computers had become thousands of times faster than they were in 1978, but the shared media Ethernet network remained the same. Hence, engineers had to invent temporary solutions until a faster, higher-bandwidth network became available. One solution was to use multiple Ethernets to interconnect machines and to connect those Ethernets with internetworking devices that could transfer traffic from one Ethernet to another, as needed. Such devices allow individual Ethernets to operate in parallel, thereby increasing the aggregate interconnection bandwidth of a collection of computers. In effect, these devices provide similar functionality to the switches described previously for point-to-point networks.

Figure E.30 shows the potential parallelism that can be gained. Depending on how they pass traffic and what kinds of interconnections they can join together, these devices have different names:

- **Bridges**—These devices connect LANs together, passing traffic from one side to another depending on the addresses in the packet. Bridges operate at the Ethernet protocol level and are usually simpler and cheaper than routers, discussed next. Using the notation of the OSI model described in the next section (see Figure E.33 on page E-82), bridges operate at layer 2, the data link layer.

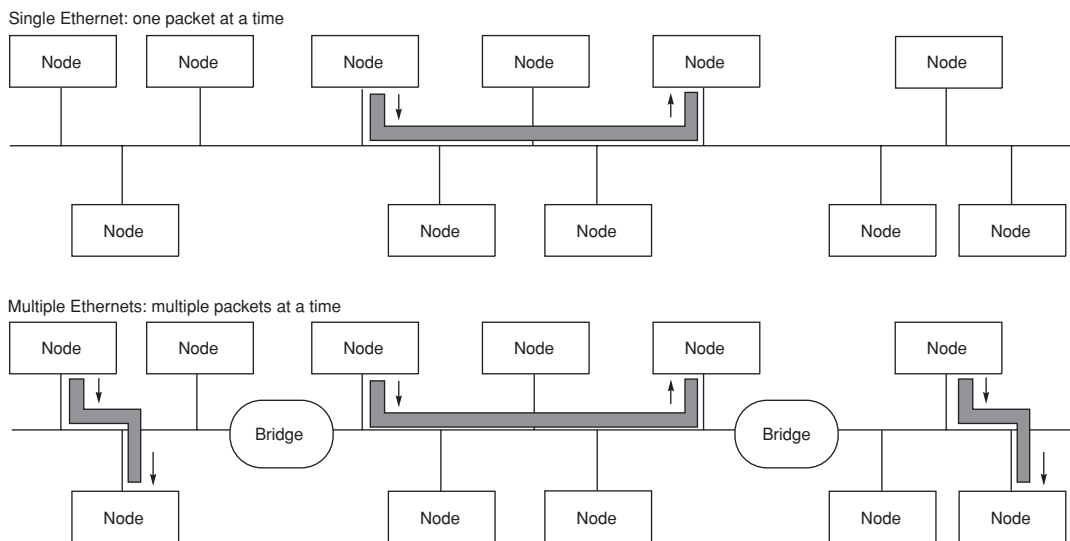

**Figure E.30** The potential increased bandwidth of using many Ethernets and bridges.

- Routers or *gateways*—These devices connect LANs to WANs, or WANs to WANs, and resolve incompatible addressing. Generally slower than bridges, they operate at OSI layer 3, the network layer. WAN routers divide the network into separate smaller subnets, which simplifies manageability and improves security.

The final internetworking devices are *hubs*, but they merely extend multiple segments into a single LAN. Thus, hubs do not help with performance, as only one message can transmit at a time. Hubs operate at OSI layer 1, called the physical layer. Since these devices were not planned as part of the Ethernet standard, their ad hoc nature has added to the difficulty and cost of maintaining LANs.

As of 2006, Ethernet link speeds are available at 10, 100, 1000, and 10,000 Mbits/sec. Although 10 and 100 Mbits/sec Ethernets share the media with multiple devices, 1000 Mbits/sec and above Ethernets rely on point-to-point links and switches. Ethernet switches normally use some form of store-and-forward.

Ethernet has no real flow control, dating back to its first instantiation. It originally used carrier sensing with exponential back-off (see page E-23) to arbitrate for the shared media. Some switches try to use that interface to retrofit their version of flow control, but flow control is not part of the Ethernet standard.

## Wide Area Network: ATM

*Asynchronous Transfer Mode* (ATM) is a wide area networking standard set by the telecommunications industry. Although it flirted as competition to Ethernet as a LAN in the 1990s, ATM has since retreated to its WAN stronghold.

The telecommunications standard has scalable bandwidth built in. It starts at 155 Mbits/sec, and scales by factors of 4 to 620 Mbits/sec, 2480 Mbits/sec, and so on. Since it is a WAN, ATM's medium is fiber, both single mode and multi-mode. Although it is a switched medium, unlike the other examples, it relies on virtual connections for communication. ATM uses virtual channels for routing to multiplex different connections on a single network segment, thereby avoiding the inefficiencies of conventional connection-based networking. The WAN focus also led to store-and-forward switching. Unlike the other protocols, Figure E.27 shows ATM has a small, fixed-sized packet with 48 bytes of payload. It uses a credit-based flow control scheme as opposed to IP routers that do not implement flow control.

The reason for virtual connections and small packets is quality of service. Since the telecommunications industry is concerned about voice traffic, predictability matters as well as bandwidth. Establishing a virtual connection has less variability than connectionless networking, and it simplifies store-and-forward switching. The small, fixed packet also makes it simpler to have fast routers and switches. Toward that goal, ATM even offers its own protocol stack to compete with TCP/IP. Surprisingly, even though the switches are simple, the ATM suite of protocols is large and complex. The dream was a seamless infrastructure from LAN to WAN, avoiding the hodgepodge of routers common today. That dream has faded from inspiration to nostalgia.



## E.9 Internetworking

Undoubtedly one of the most important innovations in the communications community has been internetworking. It allows computers on independent and incompatible networks to communicate reliably and efficiently. Figure E.31 illustrates the need to traverse between networks. It shows the networks and machines involved in transferring a file from Stanford University to the University of California at Berkeley, a distance of about 75 km.

The low cost of internetworking is remarkable. For example, it is vastly less expensive to send electronic mail than to make a coast-to-coast telephone call and leave a message on an answering machine. This dramatic cost improvement is achieved using the same long-haul communication lines as the telephone call, which makes the improvement even more impressive.

The enabling technologies for internetworking are software standards that allow reliable communication without demanding reliable networks. The under-

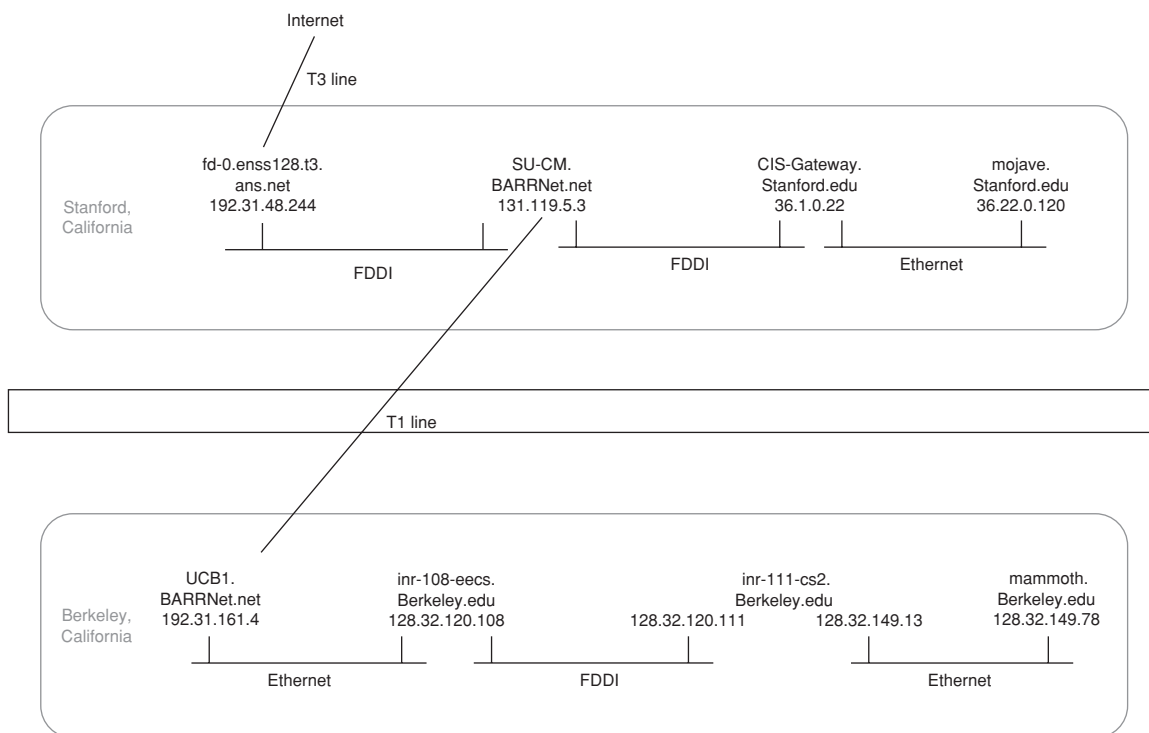

**Figure E.31** The connection established between `mojave.stanford.edu` and `mammoth.berkeley.edu` (1995). FDDI is a 100 Mbit/sec LAN, while a T1 line is a 1.5 Mbit/sec telecommunications line and a T3 is a 45 Mbit/sec telecommunications line. BARRNet stands for Bay Area Research Network. Note that `inr-111-cs2.Berkeley.edu` is a router with two Internet addresses, one for each port.

lying principle of these successful standards is that they were composed as a hierarchy of layers, each layer taking responsibility for a portion of the overall communication task. Each computer, network, and switch implements its layer of the standards, relying on the other components to faithfully fulfill their responsibilities. These layered software standards are called protocol families or protocol suites. They enable applications to work with any interconnection without extra work by the application programmer. Figure E.32 suggests the hierarchical model of communication.

The most popular internetworking standard is TCP/IP (transmission control protocol/Internet protocol). This protocol family is the basis of the humbly named Internet, which connects hundreds of millions of computers around the world. This popularity means TCP/IP is used even when communicating locally across compatible networks; for example, the network file system NFS uses IP even though it is very likely to be communicating across a homogenous LAN such as Ethernet. We use TCP/IP as our protocol family example; other protocol families follow similar lines. Section E.13 gives the history of TCP/IP.

The goal of a family of protocols is to simplify the standard by dividing responsibilities hierarchically among layers, with each layer offering services needed by the layer above. The application program is at the top, and at the bottom is the physical communication medium, which sends the bits. Just as abstract data types simplify the programmer's task by shielding the programmer from details of the implementation of the data type, this layered strategy makes the standard easier to understand.

There were many efforts at network protocols, which led to confusion in terms. Hence, Open Systems Interconnect (OSI) developed a model that popularized describing networks as a series of layers. Figure E.33 shows the model. Although all protocols do not exactly follow this layering, the nomenclature for the different layers is widely used. Thus, you can hear discussions about a simple layer 3 switch versus a layer 7 smart switch.

The key to protocol families is that communication occurs logically at the same level of the protocol in both sender and receiver, but services of the lower level implement it. This style of communication is called *peer-to-peer*. As an analogy, imagine that General A needs to send a message to General B on the

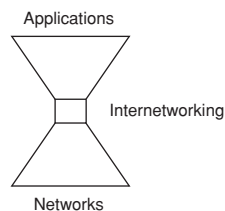

**Figure E.32** The role of internetworking. The width indicates the relative number of items at each level.

Layer number	Layer name	Main function	Example protocol	Network component
7	Application	Used for applications specifically written to run over the network	FTP, DNS, NFS, http	gateway, smart switch
6	Presentation	Translates from application to network format, and vice versa		gateway
5	Session	Establishes, maintains, and ends sessions across the network	Named pipes, RPC	gateway
4	Transport	Additional connection below the session layer	TCP	gateway
3	Network	Translates logical network address and names to their physical address (e.g., computer name to MAC address)	IP	router, ATM switch
2	Data Link	Turns packets into raw bits and at the receiving end turns bits into packets	Ethernet	bridge, network interface card
1	Physical	Transmits raw bit stream over physical cable	IEEE 802	hub

**Figure E.33** The OSI model layers. Based on [www.geocities.com/SiliconValley/Monitor/3131/ne/osimodel.html](http://www.geocities.com/SiliconValley/Monitor/3131/ne/osimodel.html).

battlefield. General A writes the message, puts it in an envelope addressed to General B, and gives it to a colonel with orders to deliver it. This colonel puts it in an envelope, and writes the name of the corresponding colonel who reports to General B, and gives it to a major with instructions for delivery. The major does the same thing and gives it to a captain, who gives it to a lieutenant, who gives it to a sergeant. The sergeant takes the envelope from the lieutenant, puts it into an envelope with the name of a sergeant who is in General B's division, and finds a private with orders to take the large envelope. The private borrows a motorcycle and delivers the envelope to the other sergeant. Once it arrives, it is passed up the chain of command, with each person removing an outer envelope with his name on it and passing on the inner envelope to his superior. As far as General B can tell, the note is from another general. Neither general knows who was involved in transmitting the envelope, nor how it was transported from one division to the other.

Protocol families follow this analogy more closely than you might think, as Figure E.34 shows. The original message includes a header and possibly a trailer sent by the lower-level protocol. The next-lower protocol in turn adds its own header to the message, possibly breaking it up into smaller messages if it is too large for this layer. Reusing our analogy, a long message from the general is divided and placed in several envelopes if it could not fit in one. This division of the message and appending of headers and trailers continues until the message descends to the physical transmission medium. The message is then sent to the destination. Each level of the protocol family on the receiving end will check the message at its level and peel off its headers and trailers, passing it on to the next

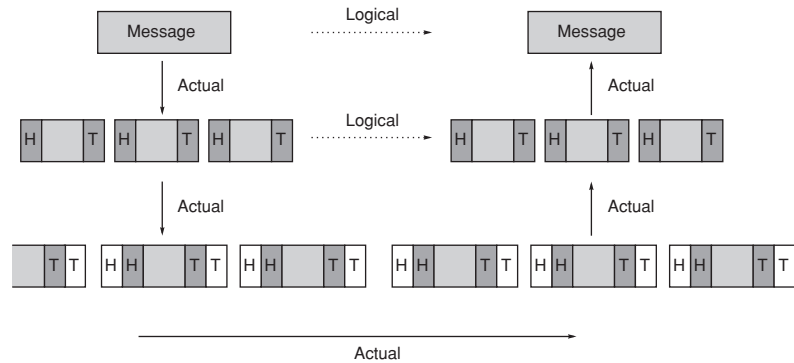

**Figure E.34** A generic protocol stack with two layers. Note that communication is peer-to-peer, with headers and trailers for the peer added at each sending layer and removed by each receiving layer. Each layer offers services to the one above to shield it from unnecessary details.

higher level and putting the pieces back together. This nesting of protocol layers for a specific message is called a *protocol stack*, reflecting the last in, first out nature of the addition and removal of headers and trailers.

As in our analogy, the danger in this layered approach is the considerable latency added to message delivery. Clearly, one way to reduce latency is to reduce the number of layers. But keep in mind that protocol families define a standard, but do not force how to implement the standard. Just as there are many ways to implement an instruction set architecture, there are many ways to implement a protocol family.

Our protocol stack example is TCP/IP. Let's assume that the bottom protocol layer is Ethernet. The next level up is the Internet Protocol or IP layer; the official term for an IP packet is a datagram. The IP layer routes the datagram to the destination machine, which may involve many intermediate machines or switches. IP makes a best effort to deliver the packets but does not guarantee delivery, content, or order of datagrams. The TCP layer above IP makes the guarantee of reliable, in-order delivery and prevents corruption of datagrams.

Following the example in Figure E.34, assume an application program wants to send a message to a machine via an Ethernet. It starts with TCP. The largest number of bytes that can be sent at once is 64 KB. Since the data may be much larger than 64 KB, TCP must divide them into smaller segments and reassemble them in proper order upon arrival. TCP adds a 20-byte header (Figure E.35) to every datagram and passes them down to IP. The IP layer above the physical layer adds a 20-byte header, also shown in Figure E.35. The data sent down from the IP level to the Ethernet are sent in packets with the format shown in Figure E.27. Note that the TCP packet appears inside the data portion of the IP datagram, just as Figure E.34 suggests.

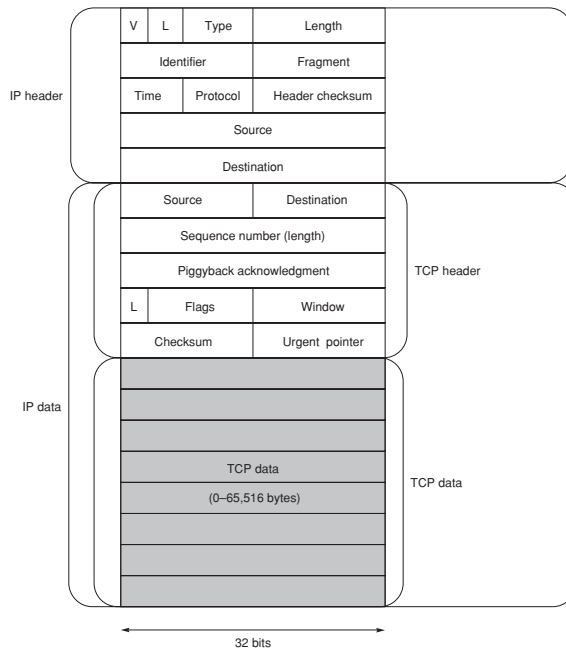

**Figure E.35** The headers for IP and TCP. This drawing is 32 bits wide. The standard headers for both are 20 bytes, but both allow the headers to optionally lengthen for rarely transmitted information. Both headers have a length of header field (L) to accommodate the optional fields, as well as source and destination fields. The length field of the whole datagram is in a separate length field in IP, while TCP combines the length of the datagram with the sequence number of the datagram by giving the sequence number in bytes. TCP uses the checksum field to be sure that the datagram is not corrupted, and the sequence number field to be sure the datagrams are assembled into the proper order when they arrive. IP provides checksum error detection only for the header, since TCP has protected the rest of the packet. One optimization is that TCP can send a sequence of datagrams before waiting for permission to send more. The number of datagrams that can be sent without waiting for approval is called the *window*, and the window field tells how many bytes may be sent beyond the byte being acknowledged by this datagram. TCP will adjust the size of the window depending on the success of the IP layer in sending datagrams; the more reliable and faster it is, the larger TCP makes the window. Since the window slides forward as the data arrive and are acknowledged, this technique is called a *sliding window protocol*. The piggyback acknowledgment field of TCP is another optimization. Since some applications send data back and forth over the same connection, it seems wasteful to send a datagram containing only an acknowledgment. This piggyback field allows a datagram carrying data to also carry the acknowledgment for a previous transmission, “piggybacking” on top of a data transmission. The urgent pointer field of TCP gives the address within the datagram of an important byte, such as a break character. This pointer allows the application software to skip over data so that the user doesn’t have to wait for all prior data to be processed before seeing a character that tells the software to stop. The identifier field and fragment field of IP allow intermediary machines to break the original datagram into many smaller datagrams. A unique identifier is associated with the original datagram and placed in every fragment, with the fragment field saying which piece is which. The time-to-live field allows a datagram to be killed off after going through a maximum number of intermediate switches no matter where it is in the network. Knowing the maximum number of hops that it will take for a datagram to arrive—if it ever arrives—simplifies the protocol software. The protocol field identifies which possible upper layer protocol sent the IP datagram; in our case, it is TCP. The V (for version) and type fields allow different versions of the IP protocol software for the network. Explicit version numbering is included so that software can be upgraded gracefully machine by machine, without shutting down the entire network. In 2006, version six of the Internet protocol (IPv6) was widely used.

## Crosscutting Issues for Interconnection Networks

This section describes five topics discussed in other chapters that are fundamentally impacted by interconnection networks, and vice versa.

### Density-Optimized Processors versus SPEC-Optimized Processors

Given that people all over the world are accessing Web sites, it doesn't really matter where servers are located. Hence, many servers are kept at *collocation sites*, which charge by network bandwidth reserved and used, and by space occupied and power consumed. Desktop microprocessors in the past have been designed to be as fast as possible at whatever heat could be dissipated, with little regard to the size of the package and surrounding chips. In fact, some desktop microprocessors from Intel and AMD as recently as 2006 burned as much as 130 watts! Floor space efficiency was also largely ignored. As a result of these priorities, power is a major cost for collocation sites, and processor density is limited by the power consumed and dissipated, including within the interconnect!

With the proliferation of portable computers (notebook sales exceeded desktop sales for the first time in 2005) and their reduced power consumption and cooling demands, the opportunity exists for using this technology to create considerably denser computation. For instance, the power consumption for the Intel Pentium M in 2006 was 25 watts, yet it delivered performance close to that of a desktop microprocessor for a wide set of applications. It is therefore conceivable that performance per watt or performance per cubic foot could replace performance per microprocessor as the important figure of merit. The key is that many applications already make use of large clusters, so it is possible that replacing 64 power-hungry processors with, say, 256 power-efficient processors could be cheaper yet be software compatible. This places greater importance on power- and performance-efficient interconnection network design.

The Google cluster is a prime example of this migration to many “cooler” processors versus fewer “hotter” processors. It uses racks of up to 80 Intel Pentium III 1 GHz processors instead of more power-hungry high-end processors. Other examples include blade servers consisting of 1-inch-wide by 7-inch-high rack unit blades designed based on mobile processors. The HP ProLiant BL10e G2 blade server supports up to 20 1 GHz ultra-low-voltage Intel Pentium M processors with a 400 MHz front-side bus, 1 MB L2 cache, and up to 1 GB memory. The Fujitsu Primergy BX300 blade server supports up to 20 1.4 or 1.6 GHz Intel Pentium M processors, each with 512 MB of memory expandable to 4 GB.

### Smart Switches versus Smart Interface Cards

Figure E.36 shows a trade-off as to where intelligence can be located within a network. Generally, the question is whether to have either smarter network interfaces or smarter switches. Making one smarter generally makes the other simpler

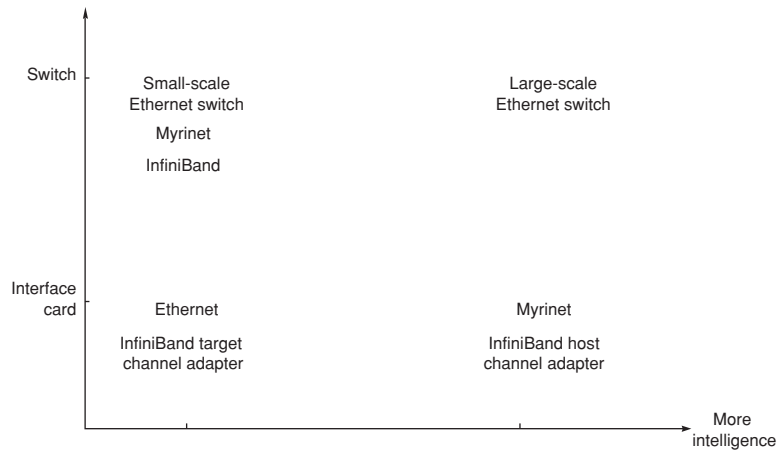

**Figure E.36 Intelligence in a network: switch versus network interface card.** Note that Ethernet switches come in two styles, depending on the size of the network, and that InfiniBand network interfaces come in two styles, depending on whether they are attached to a computer or to a storage device. Myrinet is a proprietary system area network.

and less expensive. By having an inexpensive interface, it was possible for Ethernet to become standard as part of most desktop and server computers. Lower-cost switches were made available for people with small configurations, not needing sophisticated forwarding tables and spanning-tree protocols of larger Ethernet switches.

Myrinet followed the opposite approach. Its switches are dumb components that, other than implementing flow control and arbitration, simply extract the first byte from the packet header and use it to directly select the output port. No routing tables are implemented, so the intelligence is in the network interface cards (NICs). The NICs are responsible for providing support for efficient communication and for implementing a distributed protocol for network (re)configuration. InfiniBand takes a hybrid approach by offering lower-cost, less sophisticated interface cards called target channel adapters (or TCAs) for less demanding devices such as disks—in the hope that it can be included within some I/O devices—and by offering more expensive, powerful interface cards for hosts called host channel adapters (or HCAs). The switches implement routing tables.

## Protection and User Access to the Network

A challenge is to ensure safe communication across a network without invoking the operating system in the common case. The Cray Research T3D supercomputer offers an interesting case study. Like the more recent Cray X1E, the T3D supports a global address space, so loads and stores can access memory across the network. Protection is ensured because each access is checked by the TLB. To



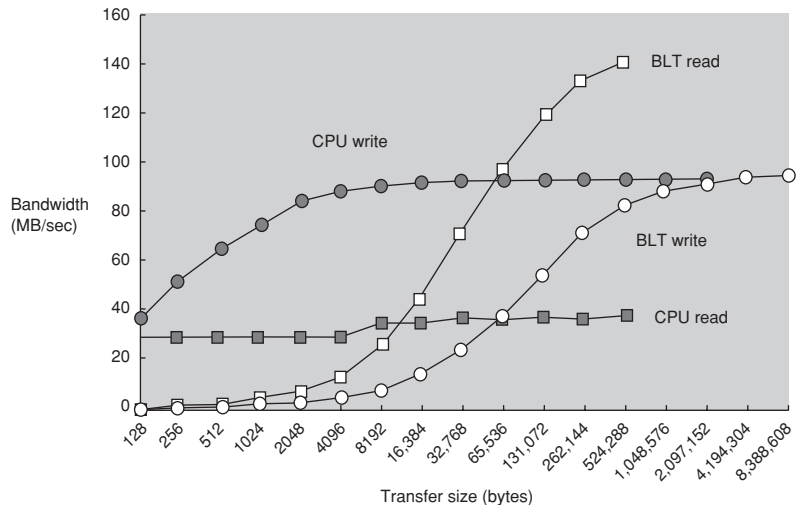

**Figure E.37** Bandwidth versus transfer size for simple memory access instructions versus a block transfer device on the Cray Research T3D. (From Arpaci et al. [1995].)

support transfer of larger objects, a block transfer engine (BLT) was added to the hardware. Protection of access requires invoking the operating system before using the BLT, to check the range of accesses to be sure there will be no protection violations.

Figure E.37 compares the bandwidth delivered as the size of the object varies for reads and writes. For very large reads (i.e., 512 KB), the BLT achieve the highest performance: 140 MB/sec. But simple loads get higher performance for 8 KB or less. For the write case, both achieve a peak of 90 MB/sec, presumably because of the limitations of the memory bus. But for writes, the BLT can only match the performance of simple stores for transfers of 2 MB; anything smaller and it's faster to send stores. Clearly, a BLT that can avoid invoking the operating system in the common case would be more useful.

## Efficient Interface to the Memory Hierarchy versus the Network

Traditional evaluations of processor performance, such as SPECint and SPECfp, encourage integration of the memory hierarchy with the processor as the efficiency of the memory hierarchy translates directly into processor performance. Hence, microprocessors have multiple levels of caches on chip along with buffers for writes. Benchmarks such as SPECint and SPECfp do not reward good interfaces to interconnection networks, and hence, many machines make the access time to the network delayed by the full memory hierarchy. Writes must lumber their way through full write buffers, and reads must go through the cycles of first-, second-, and often third-level cache misses before reaching the interconnection network. This hierarchy results in newer systems having higher latencies to the interconnect than older machines.

Let's compare three machines from the past: a 40 MHz SPARCstation-2, a 50 MHz SPARCstation-20 without an external cache, and a 50 MHz SPARCstation-20 with an external cache. According to SPECint95, this list is in order of increasing performance. The time to access the I/O bus (S-bus), however, increases in this sequence: 200 ns, 500 ns, and 1000 ns. The SPARCstation-2 is fastest because it has a single bus for memory and I/O, and there is only one level to the cache. The SPARCstation-20 memory access must first go over the memory bus (M-bus) and then to the I/O bus, adding 300 ns. Machines with a second-level cache pay an extra penalty of 500 ns before accessing the I/O bus.

## Compute-Optimized Processors versus Receiver Overhead

The overhead to receive a message likely involves an interrupt, which bears the cost of flushing and then restarting the processor pipeline, if not offloaded. As mentioned earlier, reading network status and receiving data from the network interface likely operates at cache miss speeds. If microprocessors become more superscalar and go to even faster clock rates, the number of missed instruction issue opportunities per message reception will likely rise to unacceptable levels.

---

### E.11

## Fallacies and Pitfalls

Myths and hazards are widespread with interconnection networks. This section mentions several warnings, so proceed carefully.

**Fallacy** *The interconnection network is very fast and does not need to be improved.*

The interconnection network provides certain functionality to the system, very much like the memory and I/O subsystems. It should be designed to allow processors to execute instructions at the maximum rate. The interconnection network subsystem should provide high enough bandwidth to keep from continuously entering saturation and becoming an overall system bottleneck.

In the 1980s, when wormhole switching was introduced, it became feasible to design large-diameter topologies with single-chip switches so that the bandwidth capacity of the network was not the limiting factor. This led to the flawed belief that interconnection networks need no further improvement. Since the 1980s, much attention has been placed on improving processor performance, but comparatively less has been focused on interconnection networks. As technology advances, the interconnection network tends to represent an increasing fraction of system resources, cost, power consumption, and various other attributes that impact functionality and performance. Scaling the bandwidth simply by overdimensioning certain network parameters is no longer a cost-viable option. Designers must carefully consider the end-to-end interconnection network design in concert with the processor, memory, and I/O subsystems in order to achieve the required cost, power, functionality, and performance objectives of the entire system. An obvious case in point is multicore processors with on-chip networks.

**Fallacy** *Bisection bandwidth is an accurate cost constraint of a network.*

Despite being very popular, bisection bandwidth has never been a practical constraint on the implementation of an interconnection network, although it may be one in future designs. It is more useful as a performance measure than as a cost measure. Chip pin-outs pose as the more realistic bandwidth constraint.

**Pitfall** *Using bandwidth (in particular, bisection bandwidth) as the only measure of network performance.*

It seldom is the case that aggregate network bandwidth (likewise, network bisection bandwidth) is the end-to-end bottlenecking point across the network. Even if it were the case, networks are almost never 100% efficient in transporting packets across the bisection (i.e.  $\rho < 100\%$ ) nor at receiving them at network endpoints (i.e.,  $\sigma < 100\%$ ). The former is highly dependent upon routing, switching, arbitration, and other such factors while both the former and the latter are highly dependent upon traffic characteristics. Ignoring these important factors and concentrating only on raw bandwidth can give very misleading performance predictions. For example, it is perfectly conceivable that a network could have higher aggregate bandwidth and/or bisection bandwidth relative to another network but also have lower measured performance!

Apparently, given sophisticated protocols like TCP/IP that maximize delivered bandwidth, many network companies believe that there is only one figure of merit for networks. This may be true for some applications, such as video streaming, where there is little interaction between the sender and the receiver. Many applications, however, are of a request-response nature, and so for every large message there must be one or more small messages. One example is NFS.

Figure E.38 compares a shared 10 Mbit/sec Ethernet LAN to a switched 155 Mbit/sec ATM LAN for NFS traffic. Ethernet drivers were better tuned than the ATM drivers, such that 10 Mbit/sec Ethernet was faster than 155 Mbit/sec ATM for payloads of 512 bytes or less. Figure E.38 shows the overhead time, transmission time, and total time to send all the NFS messages over Ethernet and ATM. The peak link speed of ATM is 15 times faster, and the measured link speed for 8 KB messages is almost 9 times faster. Yet the higher overheads offset the benefits so that ATM would transmit NFS traffic only 1.2 times faster.

**Pitfall** *Not providing sufficient reception link bandwidth, which causes the network end nodes to become even more of a bottleneck to performance.*

Unless the traffic pattern is a permutation, several packets will concurrently arrive at some destinations when most source devices inject traffic, thus producing contention. If this problem is not addressed, contention may turn into congestion that will spread across the network. This can be dealt with by analyzing traffic patterns and providing extra reception bandwidth. For example, it is possible to implement more reception bandwidth than injection bandwidth. The IBM Blue Gene/L, for example, implements an on-chip switch with 7-bit injection and 12-bit reception links, where the reception BW equals the aggregate switch input link BW.

Size	Number of messages	Overhead (sec)		Number of data bytes	Transmission (sec)		Total time (sec)	
		ATM	Ethernet		ATM	Ethernet	ATM	Ethernet
32	771,060	532	389	33,817,052	4	48	536	436
64	56,923	39	29	4,101,088	0	5	40	34
96	4,082,014	2,817	2,057	428,346,316	46	475	2,863	2,532
128	5,574,092	3,846	2,809	779,600,736	83	822	3,929	3,631
160	328,439	227	166	54,860,484	6	56	232	222
192	16,313	11	8	3,316,416	0	3	12	12
224	4,820	3	2	1,135,380	0	1	3	4
256	24,766	17	12	9,150,720	1	9	18	21
512	32,159	22	16	25,494,920	3	23	25	40
1,024	69,834	48	35	70,578,564	8	72	56	108
1,536	8,842	6	4	15,762,180	2	14	8	19
2,048	9,170	6	5	20,621,760	2	19	8	23
2,560	20,206	14	10	56,319,740	6	51	20	61
3,072	13,549	9	7	43,184,992	4	39	14	46
3,584	4,200	3	2	16,152,228	2	14	5	17
4,096	67,808	47	34	285,606,596	29	255	76	290
5,120	6,143	4	3	35,434,680	4	32	8	35
6,144	5,858	4	3	37,934,684	4	34	8	37
7,168	4,140	3	2	31,769,300	3	28	6	30
8,192	287,577	198	145	2,390,688,480	245	2,132	444	2,277
<b>Total</b>	11,387,913	7,858	5,740	4,352,876,316	452	4,132	8,310	9,872

**Figure E.38** Total time on a 10 Mbit Ethernet and a 155 Mbit ATM, calculating the total overhead and transmission time separately. Note that the size of the headers needs to be added to the data bytes to calculate transmission time. The higher overhead of the software driver for ATM offsets the higher bandwidth of the network. These measurements were performed in 1994 using SPARCstation 10s, the ForeSystems SBA-200 ATM interface card, and the Fore Systems ASX-200 switch. (NFS measurements taken by Mike Dahlin of U.C. Berkeley.)

**Pitfall** *Using high-performance network interface cards but forgetting about the I/O subsystem that sits between the network interface and the host processor.*

This issue is related to the previous one. Messages are usually composed in user space buffers and later sent by calling a send function from the communications library. Alternatively, a cache controller implementing a cache coherence protocol may compose a message in some SANs and in OCNs. In both cases, messages have to be copied to the network interface memory before transmission. If the I/O bandwidth is lower than the link bandwidth or introduces significant overhead, this is going to affect communication performance significantly. As an

example, the first 10 Gigabit Ethernet cards in the market had a PCI-X bus interface for the system with a significantly lower bandwidth than 10 Gbps.

**Fallacy** *Zero-copy protocols do not require copying messages or fragments from one buffer to another.*

Traditional communication protocols for computer networks allow access to communication devices only through system calls in supervisor mode. As a consequence of this, communication routines need to copy the corresponding message from the user buffer to a kernel buffer when sending a message. Note that the communication protocol may need to keep a copy of the message for retransmission in case of error, and the application may modify the contents of the user buffer once the system call returns control to the application. This buffer-to-buffer copy is eliminated in zero-copy protocols because the communication routines are executed in user space and protocols are much simpler.

However, messages still need to be copied from the application buffer to the memory in the network interface card (NIC) so that the card hardware can transmit it from there through to the network. Although it is feasible to eliminate this copy by allocating application message buffers directly in the NIC memory (and, indeed, this is done in some protocols), this may not be convenient in current systems because access to the NIC memory is usually performed through the I/O subsystem, which usually is much slower than accessing main memory. Thus, it is usually more efficient to compose the message in main memory and let DMA devices take care of the transfer to the NIC memory.

Moreover, what few people count is the copy from where the message fragments are computed (usually the ALU, with results stored in some processor register) to main memory. Some systolic-like architectures in the 1980s, like the iWarp, were able to directly transmit message fragments from the processor to the network, effectively eliminating all the message copies. This is the approach taken in the Cray X1E shared-memory multiprocessor supercomputer.

Similar comments can be made regarding the reception side. However, this does not mean that zero-copy protocols are inefficient. These protocols represent the most efficient kind of implementation used in current systems.

**Pitfall** *Ignoring software overhead when determining performance.*

Low software overhead requires cooperation with the operating system as well as with the communication libraries, but even with protocol offloading it continues to dominate the hardware overhead and must not be ignored. Figures E.29 and E.38 give two examples, one for a SAN standard and the other for a WAN standard. Other examples come from proprietary SANs for supercomputers. The Connection Machine CM-5 supercomputer in the early 1990s had a software overhead of 20  $\mu$ s to send a message and a hardware overhead of only 0.5  $\mu$ s. The first Intel Paragon supercomputer built in the early 1990s had a hardware overhead of just 0.2  $\mu$ s, but the initial release of the software had an overhead of 250  $\mu$ s. Later releases reduced this overhead down to 25  $\mu$ s and, more recently, down

to only a few  $\mu\text{s}$ , but this still dominates the hardware overhead. The IBM Blue Gene/L has an MPI sending/receiving overhead of approximately 3  $\mu\text{s}$ , only a third of which (at most) is attributed to the hardware.

This pitfall is simply Amdahl's Law applied to networks: faster network hardware is superfluous if there is not a corresponding decrease in software overhead. The software overhead is much reduced these days with OS bypass, lightweight protocols, and protocol offloading down to a few  $\mu\text{s}$  or less, typically, but it remains a significant factor in determining performance.

**Fallacy** *MINs are more cost-effective than direct networks.*

A MIN is usually implemented using significantly fewer switches than the number of devices that need to be connected. On the other hand, direct networks usually include a switch as an integral part of each node, thus requiring as many switches as nodes to interconnect. However, nothing prevents the implementation of nodes with multiple computing devices on it (e.g., a multicore processor with an on-chip switch) or with several devices attached to each switch (i.e., bristling). In these cases, a direct network may be as (or even more) cost-effective as a MIN. Note that for a MIN, several network interfaces may be required at each node to match the bandwidth delivered by the multiple links per node provided by the direct network.

**Fallacy** *Low-dimensional direct networks achieve higher performance than high-dimensional networks such as hypercubes.*

This conclusion was drawn by several studies that analyzed the optimal number of dimensions under the main physical constraint of bisection bandwidth. However, most of those studies did not consider link pipelining, considered only very short links, and/or did not consider switch architecture design constraints. The misplaced assumption that bisection bandwidth serves as the main limit did not help matters. Nowadays, most researchers and designers believe that high-radix switches are more cost-effective than low-radix switches, including some who concluded the opposite before.

**Fallacy** *Wormhole switching achieves better performance than other switching techniques.*

Wormhole switching delivers the same no-load latency as other pipelined switching techniques, like virtual cut-through switching. The introduction of wormhole switches in the late 1980s being coincident with a dramatic increase in network bandwidth led many to believe that wormhole switching was the main reason for the performance boost. Instead, most of the performance increase came from a drastic increase in link bandwidth, which, in turn, was enabled by the ability of wormhole switching to buffer packet fragments using on-chip buffers, instead of using the node's main memory or some other off-chip source for that task. In 2005, much larger on-chip buffers are feasible, and virtual cut-through achieves the same no-load latency as wormhole while delivering much higher throughput. This does not mean that wormhole switching is dead. It continues to be the

switching technique of choice for applications in which only small buffers should be used (e.g., perhaps for on-chip networks).

**Fallacy** *Implementing a few virtual channels always increases throughput by allowing packets to pass through blocked packets ahead.*

In general, implementing a few virtual channels in a wormhole switch is a good idea because packets are likely to pass blocked packets ahead of them, thus reducing latency and significantly increasing throughput. However, the improvements are not as dramatic for virtual cut-through switches. In virtual cut-through, buffers should be large enough to store several packets. As a consequence, each virtual channel may introduce HOL blocking, possibly degrading performance at high loads. Adding virtual channels increases cost, but it may deliver little additional performance unless there are as many virtual channels as switch ports and packets are mapped to virtual channels according to their destination (i.e., virtual output queueing). It is certainly the case that virtual channels can be useful in virtual cut-through networks to segregate different traffic classes, which can be very beneficial. However, multiplexing the packets over a physical link on a flit-by-flit basis causes all the packets from different virtual channels to get delayed. The average packet delay is significantly shorter if multiplexing takes place on a packet-by-packet basis, but in this case packet size should be bounded to prevent any one packet from monopolizing the majority of link bandwidth.

**Fallacy** *Adaptive routing causes out-of-order packet delivery, thus introducing too much overhead needed to reorder packets at the destination device.*

Adaptive routing allows packets to follow alternative paths through the network depending on network traffic, and therefore adaptive routing usually introduces out-of-order packet delivery. However, this does not necessarily imply that reordering packets at the destination device is going to introduce a large overhead, making adaptive routing not useful. For example, the most efficient adaptive routing algorithms implemented in 2006 support fully adaptive routing in some virtual channels but require deterministic routing to be implemented in some other virtual channels in order to prevent deadlocks (à la the IBM Blue Gene/L). In this case, it is very easy to select between adaptive and deterministic routing for each individual packet. A single bit in the packet header can indicate to the switches whether all the virtual channels can be used or only those implementing deterministic routing. This hardware support can be used as indicated below to eliminate packet reordering overhead at the destination.

Most communication protocols for parallel computers and clusters implement two different protocols depending on message size. For short messages, an eager protocol is used in which messages are directly transmitted, and the receiving nodes use some preallocated buffer to temporarily store the incoming message. On the other hand, for long messages, a rendezvous protocol is used. In this case, a control message is sent first, requesting the destination node to allocate a buffer large enough to store the entire message. The destination node confirms buffer allocation by returning an acknowledgment, and the sender can proceed



with fragmenting the message into bounded-size packets, transmitting them to the destination.

If eager messages use only deterministic routing, it is obvious that they do not introduce any reordering overhead at the destination. On the other hand, packets belonging to a long message can be transmitted using adaptive routing. As every packet contains the sequence number within the message (or the offset from the beginning of the message), the destination node can store every incoming packet directly in its correct location within the message buffer, thus incurring no overhead with respect to using deterministic routing. The only thing that differs is the completion condition. Instead of checking that the last packet in the message has arrived, it is now necessary to count the arrived packets, notifying the end of reception when the count equals the message size. Taking into account that long messages, even if not frequent, usually consume most of the network bandwidth, it is clear that most packets can benefit from adaptive routing without introducing reordering overhead when using the protocol described above.

**Fallacy** *Adaptive routing by itself always improves network fault tolerance because it allows packets to follow alternative paths.*

Adaptive routing by itself is not enough to tolerate link and/or switch failures. Some mechanism is required to detect failures and notify them, so that the routing logic could exclude faulty paths and use the remaining ones. Moreover, while a given link or switch failure affects a certain number of paths when using deterministic routing, many more source/destination pairs could be affected by the same failure when using adaptive routing. As a consequence of this, some switches implementing adaptive routing transition to deterministic routing in the presence of failures. In this case, failures are usually tolerated by sending messages through alternative paths from the source node. As an example, the Cray T3E implements direction-order routing to tolerate a few failures. This fault-tolerant routing technique avoids cycles in the use of resources by crossing directions in order (e.g., X+, Y+, Z+, Z-, Y-, then X-). At the same time, it provides an easy way to send packets through nonminimal paths, if necessary, to avoid crossing faulty components. For instance, a packet can be initially forwarded a few hops in the X+ direction even if it has to go in the X- direction at some point later.

**Pitfall** *Trying to provide features only within the network versus end-to-end.*

The concern is that of providing at a lower level the features that can only be accomplished at the highest level, thus only partially satisfying the communication demand. Saltzer, Reed, and Clark [1984] give the end-to-end argument as follows:

The function in question can completely and correctly be specified only with the knowledge and help of the application standing at the endpoints of the communication system. Therefore, providing that questioned function as a feature of the communication system itself is not possible. [page 278]

Their example of the pitfall was a network at MIT that used several gateways, each of which added a checksum from one gateway to the next. The programmers of the application assumed the checksum guaranteed accuracy, incorrectly believing that the message was protected while stored in the memory of each gateway. One gateway developed a transient failure that swapped one pair of bytes per million bytes transferred. Over time the source code of one operating system was repeatedly passed through the gateway, thereby corrupting the code. The only solution was to correct infected source files by comparing to paper listings and repair code by hand! Had the checksums been calculated and checked by the application running on the end systems, safety would have been assured.

There is a useful role for intermediate checks at the link level, however, provided that end-to-end checking is available. End-to-end checking may show that something is broken between two nodes, but it doesn't point to where the problem is. Intermediate checks can discover the broken component.

A second issue regards performance using intermediate checks. Although it is sufficient to retransmit the whole in case of failures from the end point, it can be much faster to retransmit a portion of the message at an intermediate point rather than wait for a time-out and a full message retransmit at the end point.

**Pitfall** *Relying on TCP/IP for all networks, regardless of latency, bandwidth, or software requirements.*

The network designers on the first workstations decided it would be elegant to use a single protocol stack no matter where the destination of the message: across a room or across an ocean, the TCP/IP overhead must be paid. This might have been a wise decision back then, especially given the unreliability of early Ethernet hardware, but it sets a high software overhead barrier for commercial systems of today. Such an obstacle lowers the enthusiasm for low-latency network interface hardware and low-latency interconnection networks if the software is just going to waste hundreds of microseconds when the message must travel only dozens of meters or less. It also can use significant processor resources. One rough rule of thumb is that each Mbit/sec of TCP/IP bandwidth needs about 1 MHz of processor speed, and so a 1000 Mbit/sec link could saturate a processor with an 800–1000 MHz clock.

The flip side is that, from a software perspective, TCP/IP is the most desirable target since it is the most connected and, hence, provides the largest number of opportunities. The downside of using software optimized to a particular LAN or SAN is that it is limited. For example, communication from a Java program depends on TCP/IP, so optimization for another protocol would require creation of glue software to interface Java to it.

TCP/IP advocates point out that the protocol itself is theoretically not as burdensome as current implementations, but progress has been modest in commercial systems. There are also TCP/IP offloading engines in the market, with the hope of preserving the universal software model while reducing processor utilization and message latency. If processors continue to improve much faster than network speeds, or if multiple processors become ubiquitous, software TCP/IP may become less significant for processor utilization and message latency.

## E.12

**Concluding Remarks**

Interconnection network design is one of the most exciting areas of computer architecture development today. With the advent of new multicore processor paradigms and advances in traditional multiprocessor/cluster systems and the Internet, many challenges and opportunities exist for interconnect architecture innovation. These apply to all levels of computer systems: communication between cores on a chip, between chips on a board, between boards in a system, and between computers in a machine room, over a local area and across the globe. Irrespective of their domain of application, interconnection networks should transfer the maximum amount of information within the least amount of time for given cost and power constraints so as not to bottleneck the system. Topology, routing, arbitration, switching, and flow control are among some of the key concepts in realizing such high-performance designs.

The design of interconnection networks is end-to-end: it includes injection links, reception links, and the interfaces at network end points as much as it does the topology, switches, and links within the network fabric. It is often the case that the bandwidth and overhead at the end node interfaces are the bottleneck, yet many mistakenly think of the interconnection network to mean only the network fabric. This is as bad as processor designers thinking of computer architecture to mean only the instruction set architecture or only the microarchitecture! It is end-to-end issues and understanding of the traffic characteristics that make the design of interconnection networks challenging and very much relevant even today. For instance, the need for low end-to-end latency is driving the development of efficient network interfaces located closer to the processor/memory controller. We may soon see most multicore processors used in multiprocessor systems implementing network interfaces on-chip, devoting some core(s) to execute communication tasks. This is already the case for the IBM Blue Gene/L supercomputer, which uses one of its two cores on each processor chip for this purpose.

Networking has a long way to go from its humble shared-media beginnings. It is in “catch-up” mode, with switched-media point-to-point networks only recently displacing traditional bus-based networks in many networking domains, including on chip, I/O, and the local area. We are not near any performance plateaus, so we expect rapid advancement of WANs, LANs, SANs, and especially OCNs in the near future. Greater interconnection network performance is key to the information- and communication-centric vision of the future of our field that, so far, has benefited many millions of people around the world in various ways. As the quotes at the beginning of this appendix suggest, this revolution in *two-way* communication is at the heart of changes in the form of our human associations and actions.

**Acknowledgments**

We express our sincere thanks to the following persons who, in some way, have contributed to the contents of this edition of the appendix: Lei Chai, Scott Clark,

Jose Flich, Jose Manuel Garcia, Paco Gilabert, Rama Govindaraju, Manish Gupta, Wai Hong Ho, Siao Jer, Steven Keckler, Dhabaleswar (D.K.) Panda, Fabrizio Petrini, Steve Scott, Jeonghee Shin, Craig Stunkel, Sayantan Sur, Michael B. Taylor, and Bilal Zafar.

---

**E.13****Historical Perspective and References**

This appendix has taken the perspective that interconnection networks for very different domains—from on-chip networks within a processor chip to wide area networks connecting computers across the globe—share many of the same concerns. With this, interconnection network concepts are presented in a unified way, irrespective of their application. However, their histories are vastly different, as evidenced by the different solutions adopted to address similar problems. The lack of significant interaction between research communities from the different domains certainly contributed to the diversity of implemented solutions. Highlighted below are relevant readings on each topic. In addition, good general texts featuring WAN and LAN networking have been written by Davie, Peterson, and Clark [1999] and by Kurose and Ross [2001]. Good texts focused on SANs for multiprocessors and clusters have been written by Duato, Yalamanchili, and Ni [2003] and by Dally and Towles [2004]. An informative chapter devoted to deadlock resolution in interconnection networks was written by Pinkston [2004]. Finally, an edited work by Jantsch and Tenhunen [2003] on OCNs for multicore processors and system-on-chips is also interesting reading.

**Wide Area Networks**

Wide area networks are the earliest of the data interconnection networks. The forerunner of the Internet is the ARPANET, which in 1969 connected computer science departments across the United States that had research grants funded by the Advanced Research Project Agency (ARPA), a U.S. government agency. It was originally envisioned as using reliable communications at lower levels. Practical experience with failures of the underlying technology led to the failure-tolerant TCP/IP, which is the basis for the Internet today. Vint Cerf and Robert Kahn are credited with developing the TCP/IP protocols in the mid-1970s, winning the ACM Software Award in recognition of that achievement. Kahn [1972] is an early reference on the ideas of ARPANET. For those interested in learning more about TPC/IP, Stevens [1994–1996] has written classic books on the topic.

In 1975, there were roughly 100 networks in the ARPANET; in 1983, only 200. In 1995, the Internet encompassed 50,000 networks worldwide, about half of which were in the United States. That number is hard to calculate now, but the number of IP hosts grew by a factor of 15 from 1995 to 2000, reaching 100 million Internet hosts by the end of 2000. It has grown much faster since then. With most service providers assigning dynamic IP addresses, many local area networks using private IP addresses, and with most networks allowing wireless

connections, the total number of hosts in the Internet is nearly impossible to compute. In July 2005, the Internet Systems Consortium ([www.isc.org](http://www.isc.org)) estimated more than 350 million Internet hosts, with an annual increase of about 25% projected. Although key government networks made the Internet possible (i.e., ARPANET and NSFNET), these networks have been taken over by the commercial sector, allowing the Internet to thrive. But major innovations to the Internet are still likely to come from government-sponsored research projects rather than from the commercial sector. The National Science Foundation's new Global Environment for Network Innovation (GENI) initiative is an example of this.

The most exciting application of the Internet is the World Wide Web, developed by Tim Berners-Lee, a programmer at the European Center for Particle Research (CERN) in 1989 for information access. In 1992, a young programmer at the University of Illinois, Marc Andreessen, developed a graphical interface for the Web called Mosaic. It became immensely popular. He later became a founder of Netscape, which popularized commercial browsers. In May 1995, at the time of the second edition of this book, there were over 30,000 Web pages, and the number was doubling every two months. During the writing of the third edition of this text, there were more than 1.3 billion Web pages. In December 2005, the number of Web servers approached 75 million, having increased by 30% during that same year.

Asynchronous Transfer Mode (ATM) was an attempt to design the definitive communication standard. It provided good support for data transmission as well as digital voice transmission (i.e., phone calls). From a technical point of view, it combined the best from packet switching and circuit switching, also providing excellent support for providing quality of service (QoS). Alles [1995] offers a good survey on ATM. In 1995, no one doubted that ATM was going to be the future for this community. Ten years later, the high equipment and personnel training costs basically killed ATM, returning back to the simplicity of TCP/IP. Another important blow to ATM was its defeat by the Ethernet family in the LAN domain, where packet switching achieved significantly lower latencies than ATM, which required establishing a connection before data transmission. ATM connectionless servers were later introduced in an attempt to fix this problem, but they were expensive and posed as a central bottleneck in the LAN.

Finally, WANs today rely on optical fiber. Fiber technology has made so many advances that today WAN fiber bandwidth is often underutilized. The main reason for this is the commercial introduction of wavelength division multiplexing (WDM), which allows each fiber to transmit many data streams simultaneously over different wavelengths, thus allowing three orders of magnitude bandwidth increase in just one generation, that is, three to five years (a good text by Senior [1993] discusses optical fiber communications). However, IP routers may still become a bottleneck. At 10–40 Gbps link rates, and with thousands of ports in large core IP routers, packets must be processed very quickly—that is, within a few tens of nanoseconds. The most time-consuming operation is routing. The way IP addresses have been defined and assigned to Internet hosts makes routing very complicated, usually requiring a complex search in a tree structure

for every packet. Network processors have become popular as a cost-effective solution for implementing routing and other packet-filtering operations. They usually are RISC-like, highly multithreaded, and implement local stores instead of caches.

## Local Area Networks

ARPA's success with wide area networks led directly to the most popular local area networks. Many researchers at Xerox Palo Alto Research Center had been funded by ARPA while working at universities, and so they all knew the value of networking. In 1974, this group invented the Alto, the forerunner of today's desktop computers [Thacker, et al., 1982], and the Ethernet [Metcalf and Boggs 1976], today's LAN. This group—David Boggs, Butler Lampson, Ed McCreight, Bob Sprowl, and Chuck Thacker—became luminaries in computer science and engineering, collecting a treasure chest of awards among them.

This first Ethernet provided a 3 Mbit/sec interconnection, which seemed like an unlimited amount of communication bandwidth with computers of that era. It relied on the interconnect technology developed for the cable television industry. Special microcode support gave a round-trip time of 50  $\mu$ s for the Alto over Ethernet, which is still a respectable latency. It was Boggs' experience as a ham radio operator that led to a design that did not need a central arbiter, but instead listened before use and then varied back-off times in case of conflicts.

The announcement by Digital Equipment Corporation, Intel, and Xerox of a standard for 10 Mbit/sec Ethernet was critical to the commercial success of Ethernet. This announcement short-circuited a lengthy IEEE standards effort, which eventually did publish IEEE 802.3 as a standard for Ethernet.

There have been several unsuccessful candidates in trying to replace the Ethernet. The FDDI committee, unfortunately, took a very long time to agree on the standard, and the resulting interfaces were expensive. It was also a shared medium when switches were becoming affordable. ATM also missed the opportunity in part because of the long time to standardize the LAN version of ATM, and in part because of the high latency and poor behavior of ATM connectionless servers, as mentioned above. InfiniBand for the reasons discussed below has also faltered. As a result, Ethernet continues to be the absolute leader in the LAN environment, and it remains a strong opponent in the high-performance computing market as well, competing against the SANs by delivering high bandwidth at low cost. The main drawback of Ethernet for high-end systems is its relatively high latency and lack of support in most interface cards to implement the necessary protocols.

Because of failures of the past, LAN modernization efforts have been centered on extending Ethernet to lower-cost media such as unshielded twisted pair (UTP), switched interconnects, and higher link speeds as well as to new domains such as wireless communication. In 2006, practically all new PC motherboards and laptops implement a Fast/Gigabit Ethernet port (100/1000 Mbps), and most laptops implement a 54 Mbps Wireless Ethernet connection. Also, home wired or



wireless LANs connecting all the home appliances, set-top boxes, desktops, and laptops to a shared Internet connection are very common. Spurgeon [2006] has a nice online summary of Ethernet technology, including some of its history.

## System Area Networks

One of the first nonblocking multistage interconnection networks was proposed by Clos [1953] for use in telephone exchange offices. Building on this, many early inventions for system area networks came from their use in massively parallel processors (MPPs). One of the first MPPs was the Illiac IV, a SIMD array built in the early 1970s with 64 processing elements (“massive” at that time) interconnected using a topology based on a 2D torus that provided neighbor-to-neighbor communication. Another representative of early MPP was the Cosmic Cube, which used Ethernet interface chips to connect 64 processors in a 6-cube. Communication between nonneighboring nodes was made possible by store-and-forwarding of packets at intermediate nodes toward their final destination. A much larger and truly “massive” MPP built in the mid-1980s was the Connection Machine, a SIMD multiprocessor consisting of 64K 1-bit processing elements, which also used a hypercube with store-and-forwarding. Since these early MPP machines, interconnection networks have improved considerably.

In the 1970s through the 1990s, considerable research went into trying to optimize the topology and, later, the routing algorithm, switching, arbitration, and flow control techniques. Initially, research focused on maximizing performance with little attention paid to implementation constraints or crosscutting issues. Many exotic topologies were proposed having very interesting properties, but most of them complicated the routing. Rising from the fray was the hypercube, a very popular network in the 1980s that has all but disappeared from MPPs since the 1990s. What contributed to this shift was a performance model by Dally [1990] that showed that if the implementation is wire-limited, lower-dimensional topologies achieve better performance than higher-dimensional ones because of their wider links for a given wire budget. Many designers followed that trend assuming their designs to be wire-limited, even though most implementations were (and still are) pin-limited. Several supercomputers since the 1990s have implemented low-dimensional topologies, including the Intel Paragon, Cray T3D, Cray T3E, HP AlphaServer, Intel ASCI Red, and IBM Blue Gene/L.

Meanwhile, other designers followed a very different approach, implementing bidirectional MINs in order to reduce the number of required switches below the number of network nodes. The most popular bidirectional MIN was the fat tree topology, originally proposed by Leiserson [1985] and first used in the Connection Machine CM-5 supercomputer and, later the IBM ASCI White and ASC Purple supercomputers. This indirect topology was also used in several European parallel computers based on the Transputer. The Quadrics network has inherited characteristics from some of those Transputer-based networks. Myrinet has also evolved significantly from its first version, with Myrinet 2000 incorporating the fat tree as its principal topology. Indeed, most current implementations of SANs,



including Myrinet, InfiniBand, and Quadrics as well as future implementations such as PCI-Express Advanced Switching, are based on fat trees.

Although the topology is the most visible aspect of a network, other features also have a significant impact on performance. A seminal work that raised awareness of deadlock properties in computer systems was published by Holt [1972]. Early techniques for avoiding deadlock in store-and-forward networks were proposed by Merlin and Schweitzer [1980] and by Gunther [1981]. Pipelined switching techniques were first introduced by Kermani and Kleinrock [1979] (virtual cut-through) and improved upon by Dally and Seitz [1986] (wormhole), which significantly reduced low-load latency and the topology's impact on message latency over previously proposed techniques. Wormhole switching was initially better than virtual cut-through largely because flow control could be implemented at a granularity smaller than a packet, allowing high-bandwidth links that were not as constrained by available switch memory bandwidth. Today, virtual cut-through is usually preferred over wormhole because it achieves higher throughput due to less HOL blocking effects and is enabled by current integration technology that allows the implementation of many packet buffers per link.

Tamir and Frazier [1992] laid the groundwork for virtual output queuing with the notion of dynamically allocated multiqueues. Around this same time, Dally [1992] contributed the concept of virtual channels, which was key to the development of more efficient deadlock-free routing algorithms and congestion-reducing flow control techniques for improved network throughput. Another highly relevant contribution to routing was a new theory proposed by Duato [1993] that allowed the implementation of fully adaptive routing with just one "escape" virtual channel to avoid deadlock. Previous to this, the required number of virtual channels to avoid deadlock increased exponentially with the number of network dimensions. Pinkston and Warnakulasuriya [1997] went on to show that deadlock actually can occur very infrequently, giving credence to deadlock recovery routing approaches. Scott and Goodman [1994] were among the first to analyze the usefulness of pipelined channels for making link bandwidth independent of the time of flight. These and many other innovations have become quite popular, finding use in most high-performance interconnection networks, both past and present. The IBM Blue Gene/L, for example, implements virtual cut-through switching, four virtual channels per link, fully adaptive routing with one escape channel, and pipelined links.

MPPs represent a very small (and currently shrinking) fraction of the information technology market, giving way to bladed servers and clusters. In the United States, government programs such as the Advanced Simulation and Computing (ASC) program (formerly known as the Accelerated Strategic Computing Initiative or ASCI) have promoted the design of those machines, resulting in a series of increasingly powerful one-of-a-kind MPPs costing \$50 million to \$100 million. These days, many are basically lower-cost clusters of SMPs (see Pfister [1998] and Sterling [2001] for two perspectives on clustering). In fact, in 2005, nearly 75% of the Top500 supercomputers were clusters. Nevertheless, the design of each generation of MPPs and even clusters pushes interconnection network research forward to confront new problems arising due to sheer size and

other scaling factors. For instance, source-based routing—the simplest form of routing—does not scale well to large systems. Likewise, fat trees require increasingly longer links as the network size increases, which led IBM Blue Gene/L designers to adopt a 3D torus network with distributed routing that can be implemented with bounded-length links.

## Storage Area Networks

System area networks were originally designed for a single room or single floor (thus their distances are tens to hundreds of meters) and were for use in MPPs and clusters. In the intervening years, the acronym SAN has been co-opted to also mean storage area networks, whereby networking technology is used to connect storage devices to compute servers. Today, many refer to “storage” when they say SAN. The most widely used SAN example in 2006 was Fibre Channel (FC), which comes in many varieties, including various versions of Fibre Channel Arbitrated Loop (FC-AL) and Fibre Channel Switched (FC-SW). Not only are disk arrays attached to servers via FC links, there are even some disks with FC links attached to switches so that storage area networks can enjoy the benefits of greater bandwidth and interconnectivity of switching.

In October 2000, the InfiniBand Trade Association announced the version 1.0 specification of InfiniBand [InfiniBand Trade Association 2001]. Led by Intel, HP, IBM, Sun, and other companies, it was targeted to the high-performance computing market as a successor to the PCI bus by having point-to-point links and switches with its own set of protocols. Its characteristics are desirable potentially both for system area networks to connect clusters and for storage area networks to connect disk arrays to servers. Consequently, it has had strong competition from both fronts. On the storage area networking side, the chief competition for InfiniBand has been the rapidly improving Ethernet technology widely used in LANs. The Internet Engineering Task Force proposed a standard called iSCSI to send SCSI commands over IP networks [Satran, et al., 2001]. Given the cost advantages of the higher-volume Ethernet switches and interface cards, Gigabit Ethernet dominates the low-end and medium-range for this market. What’s more, the slow introduction of InfiniBand and its small market share delayed the development of chip sets incorporating native support for InfiniBand. Therefore, network interface cards had to be plugged into the PCI or PCI-X bus, thus never delivering on the promise of replacing the PCI bus.

It was another I/O standard, PCI-Express, that finally replaced the PCI bus. Like InfiniBand, PCI-Express implements a switched network but with point-to-point serial links. To its credit, it maintains software compatibility with the PCI bus, drastically simplifying migration to the new I/O interface. Moreover, PCI-Express benefited significantly from mass market production and has found application in the desktop market for connecting one or more high-end graphics cards, making gamers very happy. Every PC motherboard now implements one or more 16x PCI-Express interfaces. PCI-Express absolutely dominates the I/O interface, but the current standard does not provide support for interprocessor communication.

Yet another standard, Advanced Switching Interconnect (ASI), may emerge as a complementary technology to PCI-Express. ASI is compatible with PCI-Express, thus linking directly to current motherboards, but it also implements support for interprocessor communication as well as I/O. Its defenders believe that it will eventually replace both SANs and LANs with a unified network in the data center market, but ironically this was also said of InfiniBand. The interested reader is referred to Pinkston, et al., 2003 for a detailed discussion on this. There is also a new disk interface standard called serial advanced technology attachment (SATA) that is replacing parallel integrated device electronics (IDE) with serial signaling technology to allow for increased bandwidth. Most disks in the market in 2006 use this new interface, but keep in mind that Fibre Channel is still alive and well. Indeed, most of the promises made by InfiniBand in the SAN market were satisfied by Fibre Channel first, thus increasing their share of the market.

Some believe that Ethernet, PCI-Express, and SATA have the edge in the LAN, I/O interface, and disk interface areas, respectively. But the fate of the remaining storage area networking contenders depends on many factors. A wonderful characteristic of computer architecture is that such issues will not remain endless academic debates, unresolved as people rehash the same arguments repeatedly. Instead, the battle is fought in the marketplace, with well-funded and talented groups giving their best efforts at shaping the future. Moreover, constant changes to technology reward those who are either astute or lucky. The best combination of technology and follow-through has often determined commercial success. Time will tell us who will win and who will lose, at least for the next round!

## On-Chip Networks

Relative to the other network domains, on-chip networks are in their infancy. As recently as the late 1990s, the traditional way of interconnecting devices such as caches, register files, ALUs, and other functional units within a chip was to use dedicated links aimed at minimizing latency or shared buses aimed at simplicity. But with subsequent increases in the volume of interconnected devices on a single chip, the length and delay of wires to cross a chip, and chip power consumption, it has become important to share on-chip interconnect bandwidth in a more structured way, giving rise to the notion of a network on-chip. Among the first to recognize this were Agarwal [Waingold, et al., 1997] and Dally [Dally 1999; Dally and Towles 2001]. They and others argued that on-chip networks that route packets allow efficient sharing of burgeoning wire resources between many communication flows and also facilitate modularity to mitigate chip-crossing wire delay problems identified by Ho et al., [2001]. Switched on-chip networks were also viewed as providing better fault isolation and tolerance. Challenges in designing these networks were later described by Taylor et al., [2005], who also proposed a 5-tuple model for characterizing the delay of OCNs. A design process for OCNs that provides a complete synthesis flow was proposed by Bertozzi et al., [2005]. Following these early works, much research and development has

gone into on-chip network design, making this a very hot area of microarchitecture activity.

Multicore and tiled designs featuring on-chip networks have become very popular since the turn of the millennium. Pinkston and Shin [2005] provide a survey of on-chip networks used in early multicore/tiled systems. Most designs exploit the reduced wiring complexity of switched OCNs as the paths between cores/tiles can be precisely defined and optimized early in the design process, thus enabling improved power and performance characteristics. With typically tens of thousands of wires attached to the four edges of a core or tile as “pin-outs,” wire resources can be traded off for improved network performance by having very wide channels over which data can be sent broadside (and possibly scaled up or down according to the power management technique), as opposed to serializing the data over fixed narrow channels.

Rings, meshes, and crossbars are straightforward to implement in planar chip technology and routing is easily defined on them, so these were popular topological choices in early switched OCNs. It will be interesting to see if this trend continues in the future when several tens to hundreds of heterogeneous cores and tiles will likely be interconnected within a single chip, possibly using 3D integration technology. Considering that processor microarchitecture has evolved significantly from its early beginnings in response to application demands and technological advancements, we would expect to see vast architectural improvements to on-chip networks as well.

## References

- Agarwal, A. [1991]. “Limits on interconnection network performance,” *IEEE Trans. on Parallel and Distributed Systems* 2:4 (April), 398–412.
- Alles, A. [1995]. “ATM internetworking” (May), [www.cisco.com/warp/public/614/12.html](http://www.cisco.com/warp/public/614/12.html).
- Anderson, T. E., D. E. Culler, and D. Patterson [1995]. “A case for NOW (networks of workstations),” *IEEE Micro* 15:1 (February), 54–64.
- Anjan, K. V., and T. M. Pinkston [1995]. “An efficient, fully-adaptive deadlock recovery scheme: Disha,” *Proc. 22nd Int’l Symposium on Computer Architecture* (June), Italy.
- Arpaci, R. H., D. E. Culler, A. Krishnamurthy, S. G. Steinberg, and K. Yelick [1995]. “Empirical evaluation of the Cray-T3D: A compiler perspective,” *Proc. 22nd Int’l Symposium on Computer Architecture* (June), Italy.
- Bell, G., and J. Gray [2001]. “Crays, clusters and centers,” Microsoft Research Technical Report, MSR-TR-2001-76.
- Benes, V. E. [1962]. “Rearrangeable three stage connecting networks,” *Bell System Technical Journal* 41, 1481–1492.
- Bertozzi, D., A. Jalabert, S. Murali, R. Tamhankar, S. Stergiou, L. Benini, and G. De Micheli [2005]. “NoC synthesis flow for customized domain specific multiprocessor systems-on-chip,” *IEEE Trans. on Parallel and Distributed Systems* 16:2 (February), 113–130.
- Bhuyan, L. N., and D. P. Agrawal [1984]. “Generalized hypercube and hyperbus structures for a computer network,” *IEEE Trans. on Computers* 32:4 (April), 322–333.

- Brewer, E. A., and B. C. Kuszmaul [1994]. “How to get good performance from the CM-5 data network.” *Proc. Eighth Int’l Parallel Processing Symposium* (April), Cancun, Mexico.
- Clos, C. [1953]. “A study of non-blocking switching networks,” *Bell Systems Technical Journal* 32 (March), 406–424.
- Dally, W. J. [1990]. “Performance analysis of k-ary n-cube interconnection networks,” *IEEE Trans. on Computers* 39:6 (June), 775–785.
- Dally, W. J. [1992]. “Virtual channel flow control,” *IEEE Trans. on Parallel and Distributed Systems* 3:2 (March), 194–205.
- Dally, W. J. [1999]. “Interconnect limited VLSI architecture,” *Proc. of the International Interconnect Technology Conference*, San Francisco (May).
- Dally, W. J., and C. I. Seitz [1986]. “The torus routing chip,” *Distributed Computing* 1:4, 187–196.
- Dally, W. J., and B. Towles [2001]. “Route packets, not wires: On-chip interconnection networks,” *Proc. of the Design Automation Conference*, Las Vegas (June).
- Dally, W. J., and B. Towles [2004]. *Principles and Practices of Interconnection Networks*, Morgan Kaufmann Publishers, San Francisco.
- Davie, B. S., L. L. Peterson, and D. Clark [1999]. *Computer Networks: A Systems Approach*, 2nd ed., Morgan Kaufmann Publishers, San Francisco.
- Duato, J. [1993]. “A new theory of deadlock-free adaptive routing in wormhole networks,” *IEEE Trans. on Parallel and Distributed Systems* 4:12 (Dec.) 1320–1331.
- Duato, J., I. Johnson, J. Flich, F. Naven, P. Garcia, and T. Nachiondo [2005]. “A new scalable and cost-effective congestion management strategy for lossless multistage interconnection networks,” *Proc. 11th Int’l Symposium on High Performance Computer Architecture* (February), San Francisco.
- Duato, J., O. Lysne, R. Pang, and T. M. Pinkston [2005]. “Part I: A theory for deadlock-free dynamic reconfiguration of interconnection networks,” *IEEE Trans. on Parallel and Distributed Systems* 16:5 (May), 412–427.
- Duato, J., and T. M. Pinkston [2001]. “A general theory for deadlock-free adaptive routing using a mixed set of resources,” *IEEE Trans. on Parallel and Distributed Systems* 12:12 (December), 1219–1235.
- Duato, J., S. Yalamanchili, and L. Ni [2003]. *Interconnection Networks: An Engineering Approach*, 2nd printing, Morgan Kaufmann Publishers, San Francisco.
- Glass, C. J., and L. M. Ni [1992]. “The Turn Model for adaptive routing,” *Proc. 19th Int’l Symposium on Computer Architecture* (May), Australia.
- Gunther, K. D. [1981]. “Prevention of deadlocks in packet-switched data transport systems,” *IEEE Trans. on Communications* COM-29:4 (April), 512–524.
- Ho, R., K. W. Mai, and M. A. Horowitz [2001]. “The future of wires,” *Proc. of the IEEE* 89:4 (April), 490–504.
- Holt, R. C. [1972]. “Some deadlock properties of computer systems,” *ACM Computer Surveys* 4:3 (September), 179–196.
- InfiniBand Trade Association [2001]. *InfiniBand Architecture Specifications Release 1.0.a*, [www.infinibandta.org](http://www.infinibandta.org).
- Jantsch, A., and H. Tenhunen [2003]. *Networks on Chips*, eds., Kluwer Academic Publishers, The Netherlands.
- Kahn, R. E. [1972]. “Resource-sharing computer communication networks,” *Proc. IEEE* 60:11 (November), 1397–1407.
- Kermani, P., and L. Kleinrock [1979]. “Virtual cut-through: A new computer communication switching technique,” *Computer Networks* 3 (January), 267–286.

- Kurose, J. F., and K. W. Ross [2001]. *Computer Networking: A Top-Down Approach Featuring the Internet*, Addison-Wesley, Boston.
- Leiserson, C. E. [1985]. "Fat trees: Universal networks for hardware-efficient supercomputing," *IEEE Trans. on Computers* C-34:10 (October), 892–901.
- Merlin, P. M., and P. J. Schweitzer [1980]. "Deadlock avoidance in store-and-forward networks—I: Store-and-forward deadlock," *IEEE Trans. on Communications* COM-28:3 (March), 345–354.
- Metcalf, R. M. [1993]. "Computer/network interface design: Lessons from Arpanet and Ethernet." *IEEE J. on Selected Areas in Communications* 11:2 (February), 173–180.
- Metcalf, R. M., and D. R. Boggs [1976]. "Ethernet: Distributed packet switching for local computer networks," *Comm. ACM* 19:7 (July), 395–404.
- Partridge, C. [1994]. *Gigabit Networking*. Addison-Wesley, Reading, Mass.
- Peh, L. S., and W. J. Dally [2001]. "A delay model and speculative architecture for pipelined routers," *Proc. 7th Int'l Symposium on High Performance Computer Architecture* (January), Monterrey.
- Pfister, Gregory F. [1998]. *In Search of Clusters*, 2nd ed., Prentice Hall, Upper Saddle River, N.J.
- Pinkston, T. M. [2004]. "Deadlock characterization and resolution in interconnection networks (Chapter 13)," *Deadlock Resolution in Computer-Integrated Systems*, edited by M. C. Zhu and M. P. Fanti, eds., Marcel Dekkar/CRC Press, 445–492.
- Pinkston, T. M., A. Benner, M. Krause, I. Robinson, and T. Sterling [2003]. "InfiniBand: The 'de facto' future standard for system and local area networks or just a scalable replacement for PCI buses?" *Cluster Computing* (Special Issue on Communication Architecture for Clusters) 6:2 (April), 95–104.
- Pinkston, T. M., and J. Shin [2005]. "Trends toward on-chip networked microsystems," *International Journal of High Performance Computing and Networking* 3:1, 3–18.
- Pinkston, T. M., and S. Warnakulasuriya [1997]. "On deadlocks in interconnection networks," *Proc. 24th Int'l Symposium on Computer Architecture* (June), Denver.
- Puente, V., R. Beivide, J. A. Gregorio, J. M. Prellezo, J. Duato, and C. Izu [1999]. "Adaptive bubble router: A design to improve performance in torus networks," *Proc. 28th Int'l Conference on Parallel Processing* (September), Aizu-Wakamatsu, Japan.
- Saltzer, J. H., D. P. Reed, and D. D. Clark [1984]. "End-to-end arguments in system design," *ACM Trans. on Computer Systems* 2:4 (November), 277–288.
- Satran, J., D. Smith, K. Meth, C. Sapuntzakis, M. Wakeley, P. Von Stamwitz, R. Haagens, E. Zeidner, L. Dalle Ore, and Y. Klein [2001]. "iSCSI," IPS working group of IETF, Internet draft [www.ietf.org/internet-drafts/draft-ietf-ips-iscsi-07.txt](http://www.ietf.org/internet-drafts/draft-ietf-ips-iscsi-07.txt).
- Scott, S. L., and J. Goodman [1994]. "The impact of pipelined channels on k-ary n-cube networks," *IEEE Trans. on Parallel and Distributed Systems* 5:1 (January), 1–16.
- Senior, J. M. [1993]. *Optical Fiber Communications: Principles and Practice*, 2nd ed., Prentice Hall, Hertfordshire, U.K.
- Spurgeon, C. [2006]. "Charles Spurgeon's Ethernet Web Site," [www.ethermanage.com/ethernet/ethernet.html](http://www.ethermanage.com/ethernet/ethernet.html).
- Sterling, T. [2001]. *Beowulf PC Cluster Computing with Windows and Beowulf PC Cluster Computing with Linux*, MIT Press, Cambridge, Mass.
- Stevens, W. R. [1994–1996]. *TCP/IP Illustrated* (three volumes), Addison-Wesley, Reading, Mass.
- Tamir, Y., and G. Frazier [1992]. "Dynamically-allocated multi-queue buffers for VLSI communication switches," *IEEE Trans. on Computers* 41:6 (June), 725–734.



- Tanenbaum, A. S. [1988]. *Computer Networks*, 2nd ed., Prentice Hall, Englewood Cliffs, N.J.
- Taylor, M. B., W. Lee, S. P. Amarasinghe, and A. Agarwal [2005]. “Scalar operand networks,” *IEEE Trans. on Parallel and Distributed Systems* 16:2 (February), 145–162.
- Thacker, C. P., E. M. McCreight, B. W. Lampson, R. F. Sproull, and D. R. Boggs [1982]. “Alto: A personal computer,” in *Computer Structures: Principles and Examples*, D. P. Siewiorek, C. G. Bell, and A. Newell, eds., McGraw-Hill, New York, 549–572.
- von Eicken, T., D. E. Culler, S. C. Goldstein, and K. E. Schauer [1992]. “Active messages: A mechanism for integrated communication and computation,” *Proc. 19th Int’l Symposium on Computer Architecture* (May), Australia.
- Vaidya, A. S., A Sivasubramaniam, and C. R. Das [1997]. “Performance benefits of virtual channels and adaptive routing: An application-driven study,” *Proceedings of the 1997 Int’l Conference on Supercomputing* (July), Austria.
- Waingold, E., M. Taylor, D. Srikrishna, V. Sarkar, W. Lee, V. Lee, J. Kim, M. Frank, P. Finch, R. Barua, J. Babb, S. Amarasinghe, and A. Agarwal [1997]. “Baring it all to software: Raw Machines,” *IEEE Computer* 30 (September), 86–93.
- Yang, Y., and G. Mason [1991]. “Nonblocking broadcast switching networks,” *IEEE Trans. on Computers* 40:9 (September), 1005–1015.

## Exercises

Solutions to “starred” exercises are available for instructors who register at [textbooks.elsevier.com/0123704901](http://textbooks.elsevier.com/0123704901).

- ★ E.1 [15] <E.2, E.3> Is electronic communication always faster than nonelectronic means for longer distances? Calculate the time to send 1000 GB using 25 8 mm tapes and an overnight delivery service versus sending 1000 GB by FTP over the Internet. Make the following four assumptions:
- The tapes are picked up at 4 P.M. Pacific time and delivered 4200 km away at 10 A.M. Eastern time (7 A.M. Pacific time).
  - On one route the slowest link is a T3 line, which transfers at 45 Mbits/sec.
  - On another route the slowest link is a 100 Mbit/sec Ethernet.
  - You can use 50% of the slowest link between the two sites.
- Will all the bytes sent by either Internet route arrive before the overnight delivery person arrives?
- ★ E.2 [10] <E.2, E.3> For the same assumptions as Exercise E.1, what is the bandwidth of overnight delivery for a 1000 GB package?
- ★ E.3 [10] <E.2, E.3> For the same assumptions as Exercise E.1, what is the minimum bandwidth of the slowest link to beat overnight delivery? What standard network options match that speed?
- ★ E.4 [15] <E.2, E.3> The original Ethernet standard was for 10 Mbits/sec and a maximum distance of 2.5 km. How many bytes could be in flight in the original Ethernet? Assume you can use 90% of the peak bandwidth.
- ★ E.5 [15] <E.2, E.3> Flow control is a problem for WANs due to the long time of flight, as the example on page E-14 illustrates. Ethernet did not include flow con-

trol when it was first standardized at 10 Mbits/sec. Calculate the number of bytes in flight for a 10 Gbit/sec Ethernet over a 100 meter link, assuming you can use 90% of peak bandwidth. What does your answer mean for network designers?

- ★ E.6 [15] <E.2, E.3> Assume the total overhead to send a zero-length data packet on an Ethernet is 100  $\mu$ s and that an unloaded network can transmit at 90% of the peak 1000 Mbit/sec rating. For the purposes of this question, assume the size of the Ethernet header and trailer is 56 bytes. Assume a continuous stream of packets of the same size. Plot the delivered bandwidth of user data in Mbits/sec as the payload data size varies from 32 bytes to the maximum size of 1500 bytes in 32-byte increments.
- ★ E.7 [10] <E.2, E.3> Exercise E.6 suggests that the delivered Ethernet bandwidth to a single user may be disappointing. Making the same assumptions as in that exercise, by how much would the maximum payload size have to be increased to deliver half of the peak bandwidth?
- ★ E.8 [10] <E.2, E.3> One reason that ATM has a fixed transfer size is that when a short message is behind a long message, a node may need to wait for an entire transfer to complete. For applications that are time-sensitive, such as when transmitting voice or video, the large transfer size may result in transmission delays that are too long for the application. On an unloaded interconnection, what is the worst-case delay in microseconds if a node must wait for one full-size Ethernet packet versus an ATM transfer? See Figure E.27 (page E-75) to find the packet sizes. For this question assume you can transmit at 100% of the 622 Mbits/sec of the ATM network and 100% of the 1000 Mbit/sec Ethernet.
- ★ E.9 [10] <E.2, E.3> Exercise E.7 suggests the need for expanding the maximum payload to increase the delivered bandwidth, but Exercise E.8 suggests the impact on worst-case latency of making it longer. What would be the impact on latency of increasing the maximum payload size by the answer to Exercise E.7?
- ★ E.10 [12/12/20] <E.4> The Omega network shown in Figure E.11 on page E-31 consists of three columns of four switches, each with two inputs and two outputs. Each switch can be set to *straight*, which connects the upper switch input to the upper switch output and the lower input to the lower output, and to *exchange*, which connects the upper input to the lower output and vice versa for the lower input. For each column of switches, label the inputs and outputs 0, 1, . . . , 7 from top to bottom, to correspond with the numbering of the processors.
  - a. [12] <E.4> When a switch is set to exchange and a message passes through, what is the relationship between the label values for the switch input and output used by the message? (*Hint*: Think in terms of operations on the digits of the binary representation of the label number.)
  - b. [12] <E.4> Between any two switches in adjacent columns that are connected by a link, what is the relationship between the label of the output connected to the input?
  - c. [20] <E.4> Based on your results in parts (a) and (b), design and describe a simple routing scheme for distributed control of the Omega network. A mes-



sage will carry a *routing tag* computed by the sending processor. Describe how the processor computes the tag and how each switch can set itself by examining a bit of the routing tag.

- ★ E.11 [12/12/12/12/12/12] <E.4> Prove whether or not it is possible to realize the following permutations (i.e., communication patterns) on the eight-node Omega network shown in Figure E.11 on page E-31:
- [12] <E.4> Bit-reversal permutation—the node with binary coordinates  $a_{n-1}, a_{n-2}, \dots, a_1, a_0$  communicates with the node  $a_0, a_1, \dots, a_{n-2}, a_{n-1}$ .
  - [12] <E.4> Perfect shuffle permutation—the node with binary coordinates  $a_{n-1}, a_{n-2}, \dots, a_1, a_0$  communicates with the node  $a_{n-2}, a_{n-3}, \dots, a_0, a_{n-1}$  (i.e., rotate left 1 bit).
  - [12] <E.4> Bit-complement permutation—the node with binary coordinates  $a_{n-1}, a_{n-2}, \dots, a_1, a_0$  communicates with the node  $\bar{a}_{n-1}, \bar{a}_{n-2}, \dots, \bar{a}_1, \bar{a}_0$  (i.e., complement each bit).
  - [12] <E.4> Butterfly permutation—the node with binary coordinates  $a_{n-1}, a_{n-2}, \dots, a_1, a_0$  communicates with the node  $a_0, a_{n-2}, \dots, a_1, a_{n-1}$  (i.e., swap the most and least significant bits).
  - [12] <E.4> Matrix transpose permutation—the node with binary coordinates  $a_{n-1}, a_{n-2}, \dots, a_1, a_0$  communicates with the node  $a_{n/2-1}, \dots, a_0, a_{n-1}, \dots, a_{n/2}$  (i.e., transpose the bits in positions approximately halfway around).
  - [12] <E.4> Barrel-shift permutation—node  $i$  communicates with node  $i+1$  modulo  $N-1$ , where  $N$  is the total number of nodes and  $0 \leq i$ .
- ★ E.12 [12] <E.4> Design a network topology using 18-port crossbar switches that has the minimum number of switches to connect 64 nodes. Each switch port supports communication to and from one device.
- ★ E.13 [15] <E.4> Design a network topology that has the minimum latency through the switches for 64 nodes using 18-port crossbar switches. Assume unit delay in the switches and zero delay for wires.
- ★ E.14 [15] <E.4> Design a switch topology that balances the bandwidth required for all links for 64 nodes using 18-port crossbar switches. Assume a uniform traffic pattern.
- ★ E.15 [15] <E.4> Compare the interconnection latency of a crossbar, Omega network, and fat tree with eight nodes. Use Figure E.11 on page E-31, Figure E.12 on page E-33, and Figure E.14 on page E-37. Assume that the fat tree is built entirely from two-input, two-output switches so that its hardware resources are more comparable to that of the Omega network. Assume that each switch costs a unit time delay. Assume the fat tree randomly picks a path, so give the best case and worst case for each example. How long will it take to send a message from node 0 to node 6? How long will it take node 1 and node 7 to communicate?
- ★ E.16 [15] <E.4> Draw the topology of a 6-cube after the same manner of the 4-cube in Figure E.14 on page E-37. What is the maximum and average number of hops needed by packets assuming a uniform distribution of packet destinations?

- ★ E.17 [15] <E.4> Complete a table similar to Figure E.15 on page E-40 that captures the performance and cost of various network topologies, but do it for the general case of  $N$  nodes using  $k \times k$  switches instead of the specific case of 64 nodes.
- ★ E.18 [20] <E.4> Repeat the example given on page E-41, but use the bit-complement communication pattern given in Exercise E.11 instead of NEWS communication.
- ★ E.19 [15] <E.5> Give the four specific conditions necessary for deadlock to exist in an interconnection network. Which of these are removed by dimension-order routing? Which of these are removed in adaptive routing with the use of “escape” routing paths? Which of these are removed in adaptive routing with the technique of deadlock recovery (regressive or progressive)? Explain your answer.
- ★ E.20 [12/12/12/12] <E.5> Prove whether or not the following routing algorithms based on prohibiting dimensional turns are suitable to be used as escape paths for 2D meshes by analyzing whether they are both connected and deadlock-free. Explain your answer. (*Hint*: You may wish to refer to the Turn Model algorithm and/or to prove your answer by drawing a directed graph for a  $4 \times 4$  mesh that depicts dependencies between channels and verifying the channel dependency graph is free of cycles.) The routing algorithms are expressed with the following abbreviations: W = west, E = east, N = north, and S = south.
  - a. [12] <E.5> Allowed turns are from W to N, E to N, S to W, and S to E.
  - b. [12] <E.5> Allowed turns are from W to S, E to S, N to E, and S to E.
  - c. [12] <E.5> Allowed turns are from W to S, E to S, N to W, S to E, W to N, and S to W.
  - d. [12] <E.5> Allowed turns are from S to E, E to S, S to W, N to W, N to E, and E to N.
- ★ E.21 [15] <E.5> Compute and compare the upper bound for the efficiency factor,  $\rho$ , for dimension-order routing and up\*/down\* routing assuming uniformly distributed traffic on a 64 node 2D mesh network. For up\*/down\* routing, assume optimal placement of the root node (i.e., a node near the middle of the mesh). (*Hint*: You will have to find the loading of links across the network bisection carry the global load as determined by the routing algorithm.)
- ★ E.22 [15] <E.5> For the same assumptions as Exercise E.21, find the efficiency factor for up\*/down\* routing on a 64-node fat tree network using  $4 \times 4$  switches. Compare this result with the  $\rho$  found for up\*/down\* routing on a 2D mesh. Explain.
- ★ E.23 [15] <E.5> Calculate the probability of matching two-phased arbitration requests from all  $k$  input ports of a switch simultaneously to the  $k$  output ports assuming a uniform distribution of requests and grants to/from output ports. How does this compare to the matching probability for three-phased arbitration in which each of the  $k$  input ports can make two simultaneous requests (again, assuming a uniform random distribution of requests and grants)?
- ★ E.24 [15] <E.5> The equation on page E-52 shows the value of cut-through switching. Ethernet switches used to build clusters often do not support cut-through switch-

ing. Compare the time to transfer 1500 bytes over a 1000 Mbit/sec Ethernet with and without cut-through switching for a 64-node cluster. Assume each Ethernet switch takes 1.0  $\mu$ s and that a message goes through seven intermediate switches.

- ★ E.25 [15] <E.5> Making the same assumptions as in Exercise E.24, what is the difference between cut-through and store-and-forward switching for 32 bytes?
- ★ E.26 [15] <E.5> One way to reduce latency is to use larger switches. Unlike Exercise E.24, let's assume we need only three intermediate switches to connect any two nodes in the cluster. Make the same assumptions as in Exercise E.24 for the remaining parameters. What is the difference between cut-through and store-and-forward for 1500 bytes? For 32 bytes?
- ★ E.27 [20] <E.5> Using FlexSim 1.2 (<http://ceng.usc.edu/smart/FlexSim/flexsim.html>) or some other cycle-accurate network simulator, simulate a 256-node 2D torus network assuming wormhole routing, 32-flit packets, uniform (random) communication pattern, and four virtual channels. Compare the performance of deterministic routing using DOR, adaptive routing using escape paths (i.e., Duato's Protocol), and true fully adaptive routing using progressive deadlock recovery (i.e., Disha routing). Do so by plotting latency versus applied load and throughput versus applied load for each, as is done in Figure E.19 for the example on page E-53. Also run simulations and plot results for two and eight virtual channels for each. Compare and explain your results by addressing how/why the number and use of virtual channels by the various routing algorithms affect network performance. (*Hint*: Be sure to let the simulation reach steady state by allowing a warm-up period of a several thousand network cycles before gathering results.)
- ★ E.28 [20] <E.5> Repeat Exercise E.27 using bit-reversal communication instead of the uniform random communication pattern. Compare and explain your results by addressing how/why the communication pattern affects network performance.
- ★ E.29 [40] <E.5> Repeat Exercises E.27 and E.28 using 16-flit packets and 128-flit packets. Compare and explain your results by addressing how/why the packet size along with the other design parameters affect network performance.
- E.30 [20] <E.2, E.4, E.5, E.8> Figures E.7, E.16, and E.20 show interconnection network characteristics of several of the top 500 supercomputers by machine type as of the publication of the fourth edition. Update that figure to the most recent top 500. How have the systems and their networks changed since the data in the original figure? Do similar comparisons for OCNs used in microprocessors and SANs targeted for clusters using Figures E.26 and E.28.
- ★ E.31 [12/12/12/15/15/18] <E.8> Use the M/M/1 queuing model to answer this exercise. Measurements of a network bridge show that packets arrive at 200 packets per second and that the gateway forwards them in about 2 ms.
  - a. [12] <E.8> What is the utilization of the gateway?
  - b. [12] <E.8> What is the mean number of packets in the gateway?
  - c. [12] <E.8> What is the mean time spent in the gateway?
  - d. [15] <E.8> Plot response time versus utilization as you vary the arrival rate.

- e. [15] <E.8> For an M/M/1 queue, the probability of finding  $n$  or more tasks in the system is  $\text{Utilization}^n$ . What is the chance of an overflow of the FIFO if it can hold 10 messages?
  - f. [18] <E.8> How big must the gateway be to have packet loss due to FIFO overflow less than one packet per million?
- ★ E.32 [20] <E.8> The imbalance between the time of sending and receiving can cause problems in network performance. Sending too fast can cause the network to back up and increase the latency of messages, since the receivers will not be able to pull out the message fast enough. A technique called *bandwidth matching* proposes a simple solution: Slow down the sender so that it matches the performance of the receiver [Brewer and Kuszmaul 1994]. If two machines exchange an equal number of messages using a protocol like UDP, one will get ahead of the other, causing it to send all its messages first. After the receiver puts all these messages away, it will then send its messages. Estimate the performance for this case versus a bandwidth-matched case. Assume the send overhead is 200  $\mu\text{s}$ , the receive overhead is 300  $\mu\text{s}$ , time of flight is 5  $\mu\text{s}$ , latency is 10  $\mu\text{s}$ , and that the two machines want to exchange 100 messages.
- E.33 [40] <E.8> Compare the performance of UDP with and without bandwidth matching by slowing down the UDP send code to match the receive code as advised by bandwidth matching [Brewer and Kuszmaul 1994]. Devise an experiment to see how much performance changes as a result. How should you change the send rate when two nodes send to the same destination? What if one sender sends to two destinations?
- ★ E.34 [40] <E.6, E.8> If you have access to an SMP and a cluster, write a program to measure latency of communication and bandwidth of communication between processors, as was plotted in Figure E.29 on page E-77.
- E.35 [20/20/20] <E.9> If you have access to a UNIX system, use `ping` to explore the Internet. First read the manual page. Then use `ping` without option flags to be sure you can reach the following sites. It should say that `X` is `alive`. Depending on your system, you may be able to see the path by setting the flags to verbose mode (`-v`) and trace route mode (`-R`) to see the path between your machine and the example machine. Alternatively, you may need to use the program `trace-route` to see the path. If so, try its manual page. You may want to use the UNIX command `script` to make a record of your session.
- a. [20] <E.9> Trace the route to another machine on the same local area network. What is the latency?
  - b. [20] <E.9> Trace the route to another machine on your campus that is *not* on the same local area network. What is the latency?
  - c. [20] <E.9> Trace the route to another machine *off campus*. For example, if you have a friend you send email to, try tracing that route. See if you can discover what types of networks are used along that route. What is the latency?

- E.36 [15] <E.9> Use FTP to transfer a file from a remote site and then between local sites on the same LAN. What is the difference in bandwidth for each transfer? Try the transfer at different times of day or days of the week. Is the WAN or LAN the bottleneck?
- ★ E.37 [10/10] <E.9, E.11> Figure E.38 on page E-90 compares latencies for a high-bandwidth network with high overhead and a low-bandwidth network with low overhead for different TCP/IP message sizes.
- [10] <E.9, E.11> For what message sizes is the delivered bandwidth higher for the high-bandwidth network?
  - [10] <E.9, E.11> For your answer to part (a), what is the delivered bandwidth for each network?
- ★ E.38 [15] <E.9, E.11> Using the statistics in Figure E.38 on page E-90, estimate the per-message overhead for each network.
- ★ E.39 [15] <E.9, E.11> Exercise E.37 calculates which message sizes are faster for two networks with different overhead and peak bandwidth. Using the statistics in Figure E.38 on page E-90, what is the percentage of messages that are transmitted more quickly on the network with low overhead and bandwidth? What is the percentage of data transmitted more quickly on the network with high overhead and bandwidth?
- ★ E.40 [15] <E.9, E.11> One interesting measure of the latency and bandwidth of an interconnection is to calculate the size of a message needed to achieve one-half of the peak bandwidth. This halfway point is sometimes referred to as  $n_{1/2}$ , taken from the terminology of vector processing. Using Figure E.38 on page E-90, estimate  $n_{1/2}$  for TCP/IP message using 155 Mbit/sec ATM and 10 Mbit/sec Ethernet.
- E.41 [Discussion] <E.10> The Google cluster used to be constructed from 1 rack unit (RU) PCs, each with one processor and two disks. Today there are considerably denser options. How much less floor space would it take if we were to replace the 1 RU PCs with modern alternatives? Go to the Compaq or Dell Web sites to find the densest alternative. What would be the estimated impact on cost of the equipment? What would be the estimated impact on rental cost of floor space? What would be the impact on interconnection network design for achieving power/performance efficiency?
- E.42 [Discussion] <E.13> At the time of the writing of the fourth edition, it was unclear what would happen with Ethernet versus InfiniBand versus Advanced Switching in the machine room. What are the technical advantages of each? What are the economic advantages of each? Why would people maintaining the system prefer one to the other? How popular is each network today? How do they compare to proprietary commercial networks such as Myrinet and Quadrics?