

Chapter 7

Data Link Control Protocols

Contents

- Flow control
- Error control
- HDLC

Flow Control

- Ensuring the sending entity does not overwhelm the receiving entity
 - Preventing buffer overflow
- Referring to a set of procedures used to restrict the amount of data that the sender can send before waiting for acknowledgement

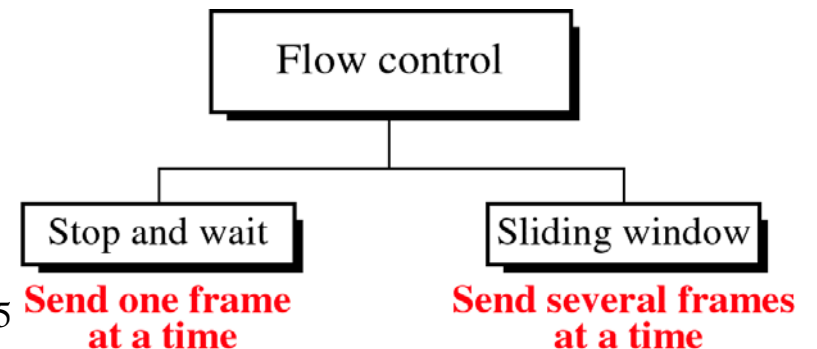

Model of Frame Transmission

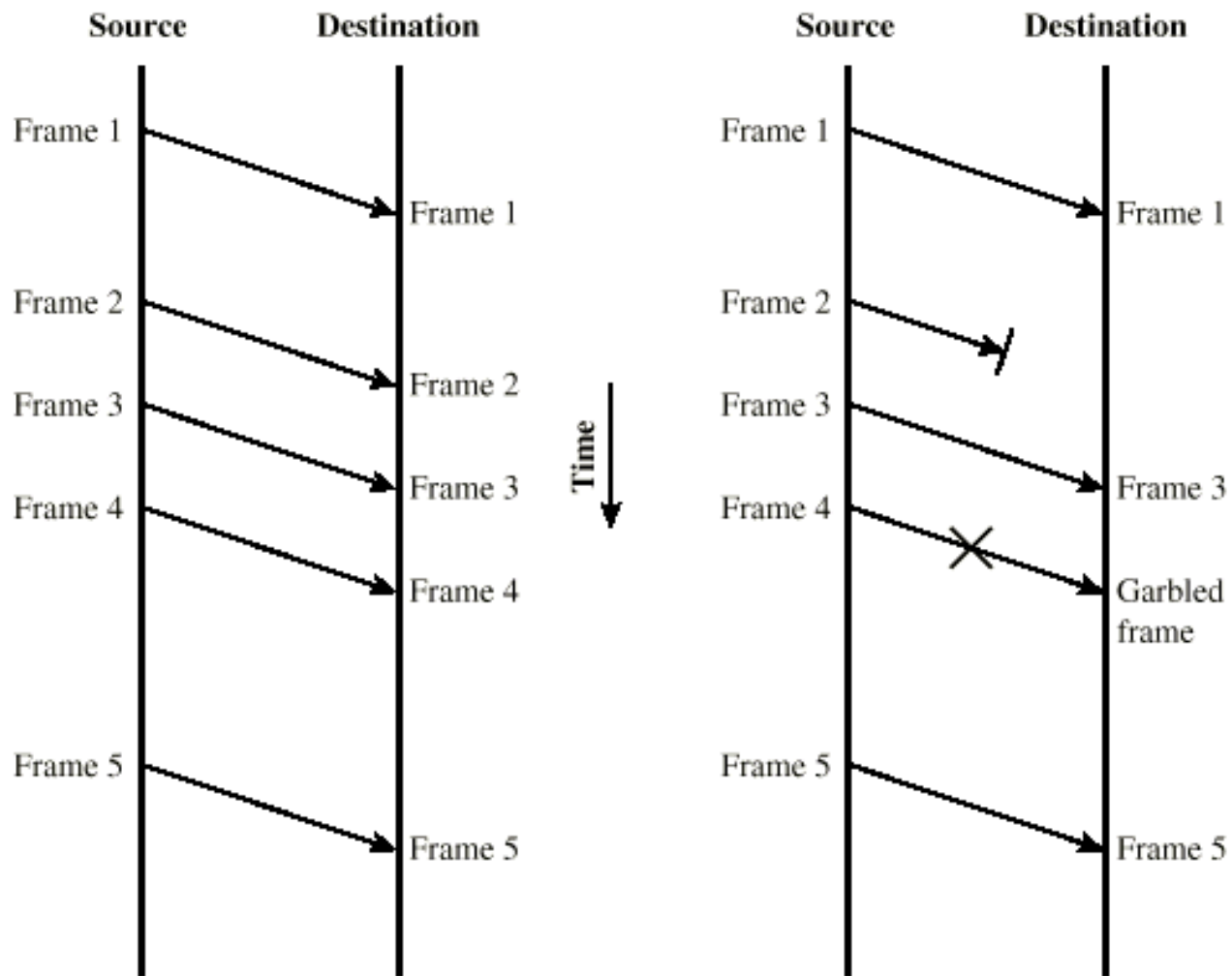

Stop and Wait

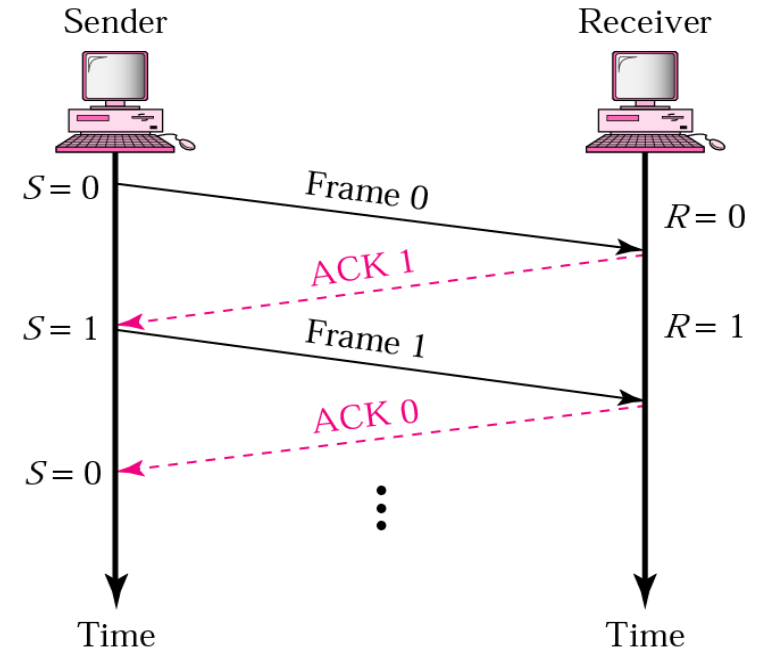

- Source transmits frame
- Destination receives frame and replies with acknowledgement
- Source waits for ACK before sending next frame
- Destination can stop flow by not sending ACK

Stop and Wait Link Utilization

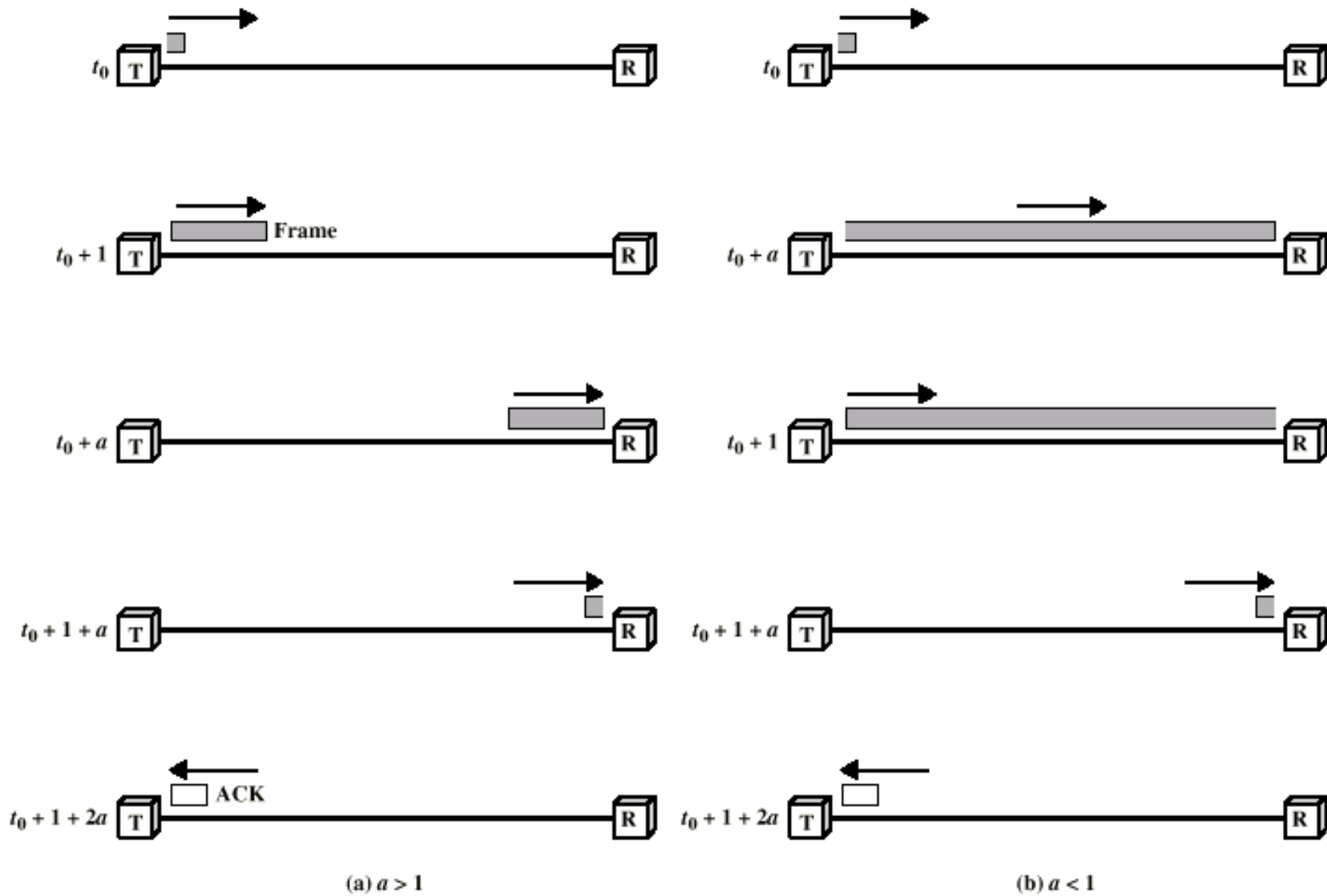

Sliding Windows Flow Control

- Allow multiple frames to be in transit
- Receiver has buffer for W frames
- Transmitter can send up to W frames without ACK
- Each frame is numbered
- ACK includes number of next frame expected
- Sequence number bounded by size of sequence number field (k)
 - Frames are numbered modulo 2^k

Sliding Window Diagram

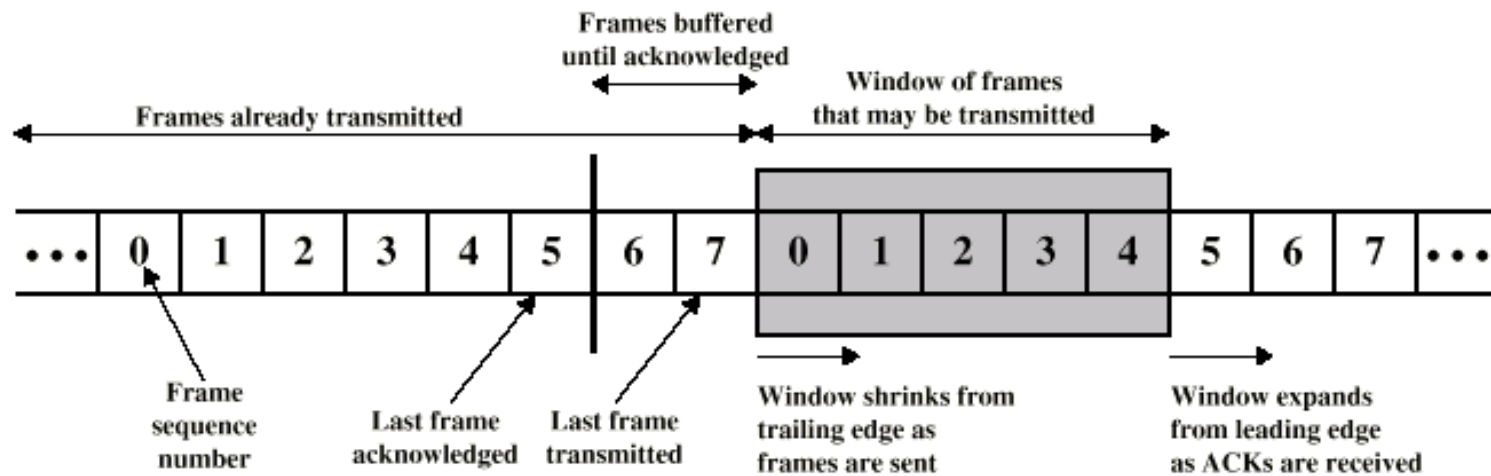

(a) Sender's perspective

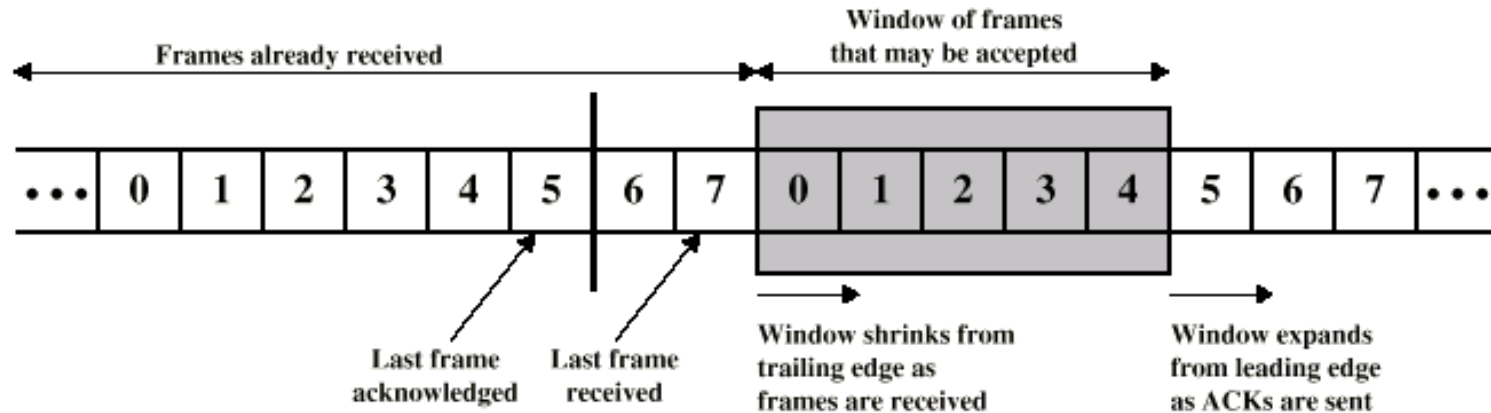

(b) Receiver's perspective

Example Sliding Window

Source System A

Destination System B

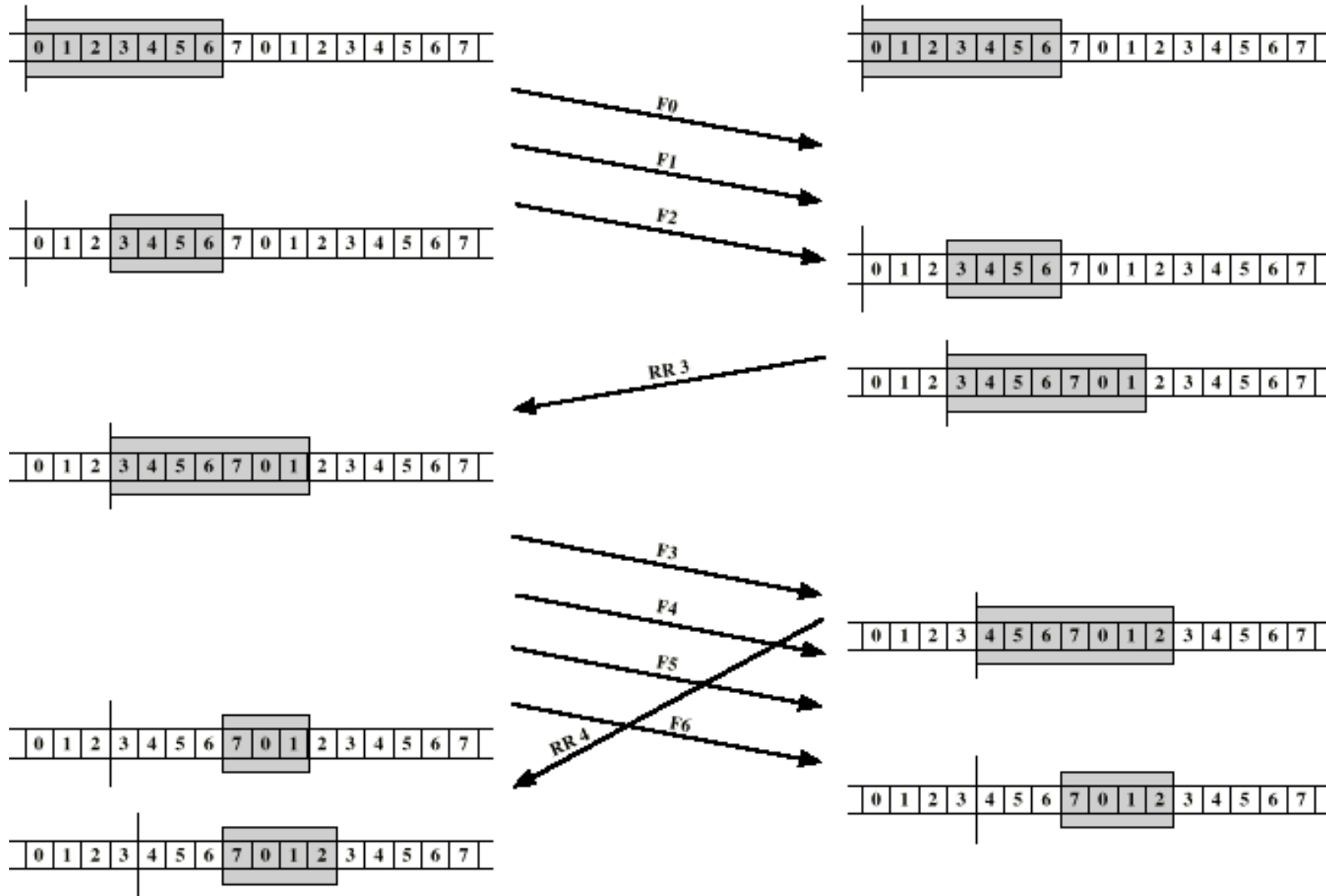

Performance Issues

- Pages 233-237

Error Control

- Detection and correction of errors
- Lost frames
- Damaged frames
- Automatic repeat request (ARQ)
 - Error detection
 - Positive acknowledgment
 - Retransmission after timeout
 - Negative acknowledgement and retransmission

Automatic Repeat Request (ARQ)

- Stop and wait
- Go back N
- Selective reject (selective retransmission)

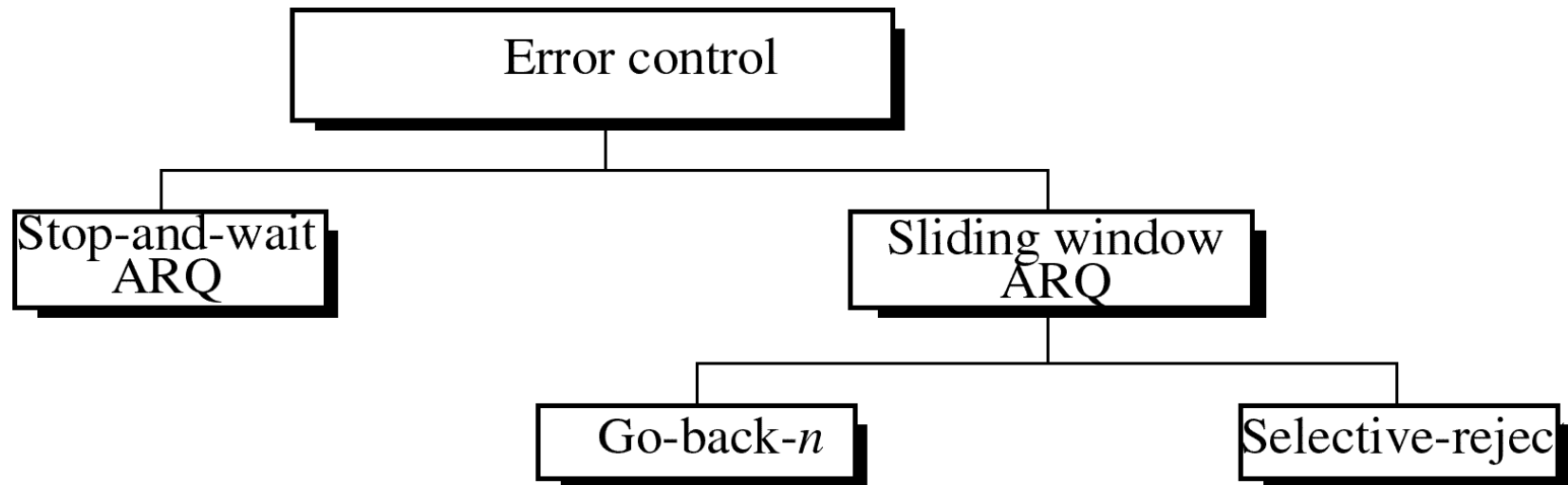

Stop and Wait

- Source transmits single frame
- Wait for ACK
- If received frame damaged, discard it
 - Transmitter has timeout
 - If no ACK within timeout, retransmit
- If ACK damaged, transmitter will not recognize it
 - Transmitter will retransmit
 - Receiver gets two copies of frame
 - Use ACK0 and ACK1
- Pros and cons:
 - Simple
 - Inefficient

Stop-and-Wait Diagram

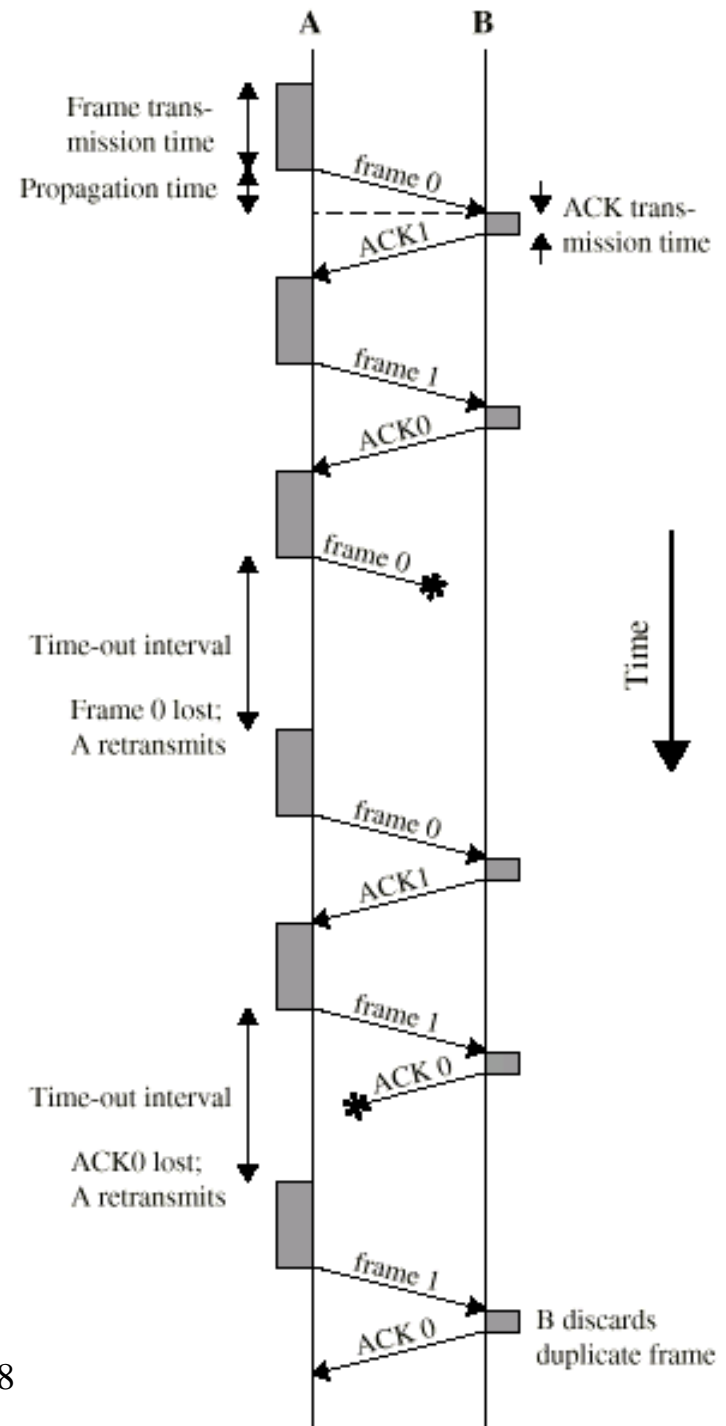

Go Back N

- Based on sliding window
- If no error, ACK as usual with next frame expected
- If error, reply with rejection
 - Discard that frame and all future frames until error frame received correctly
 - Transmitter must go back and retransmit that frame and all subsequent frames

Go Back N - Damaged Frame

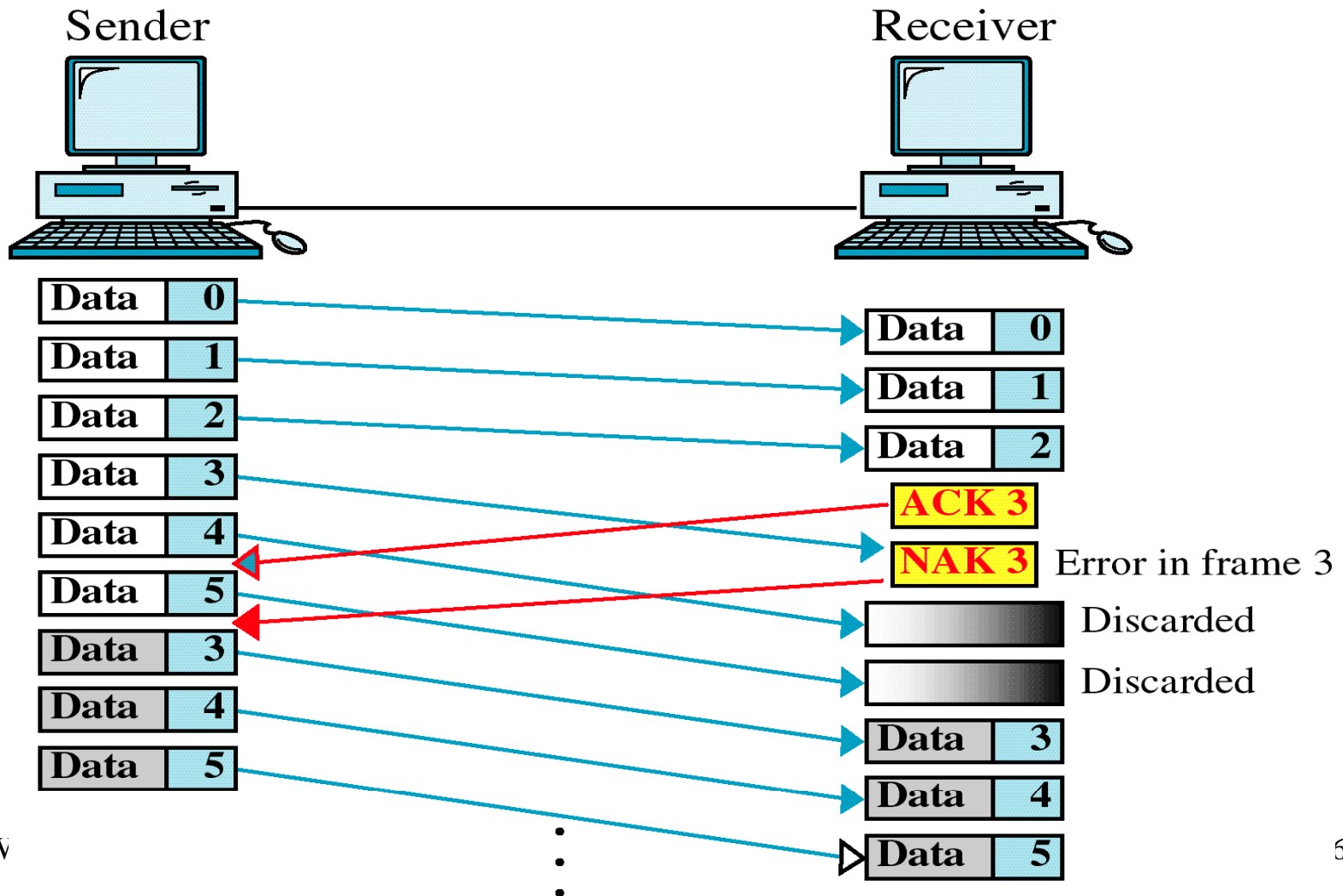

Go Back N - Lost Frame

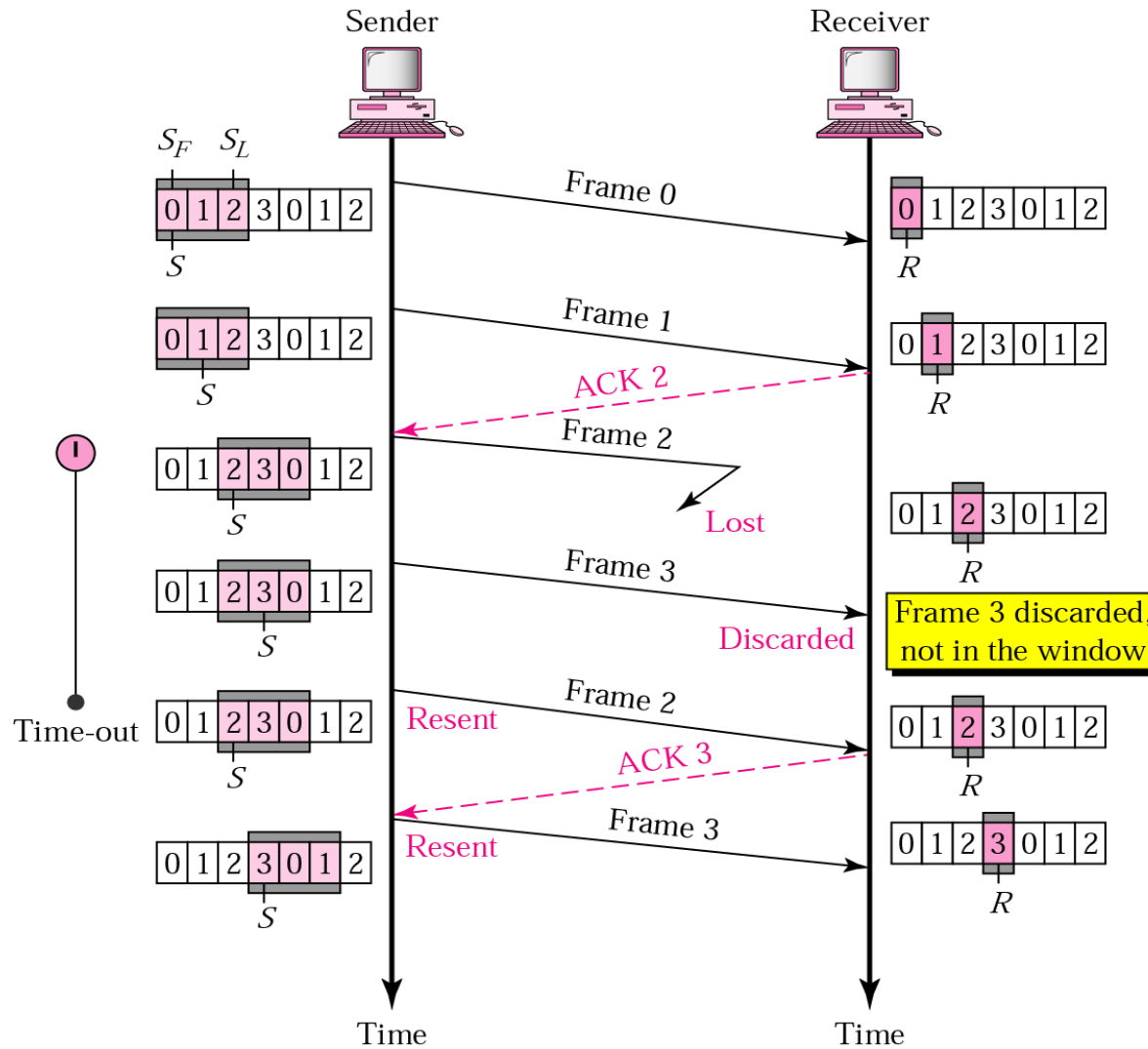

Go Back N

Damaged Acknowledgement

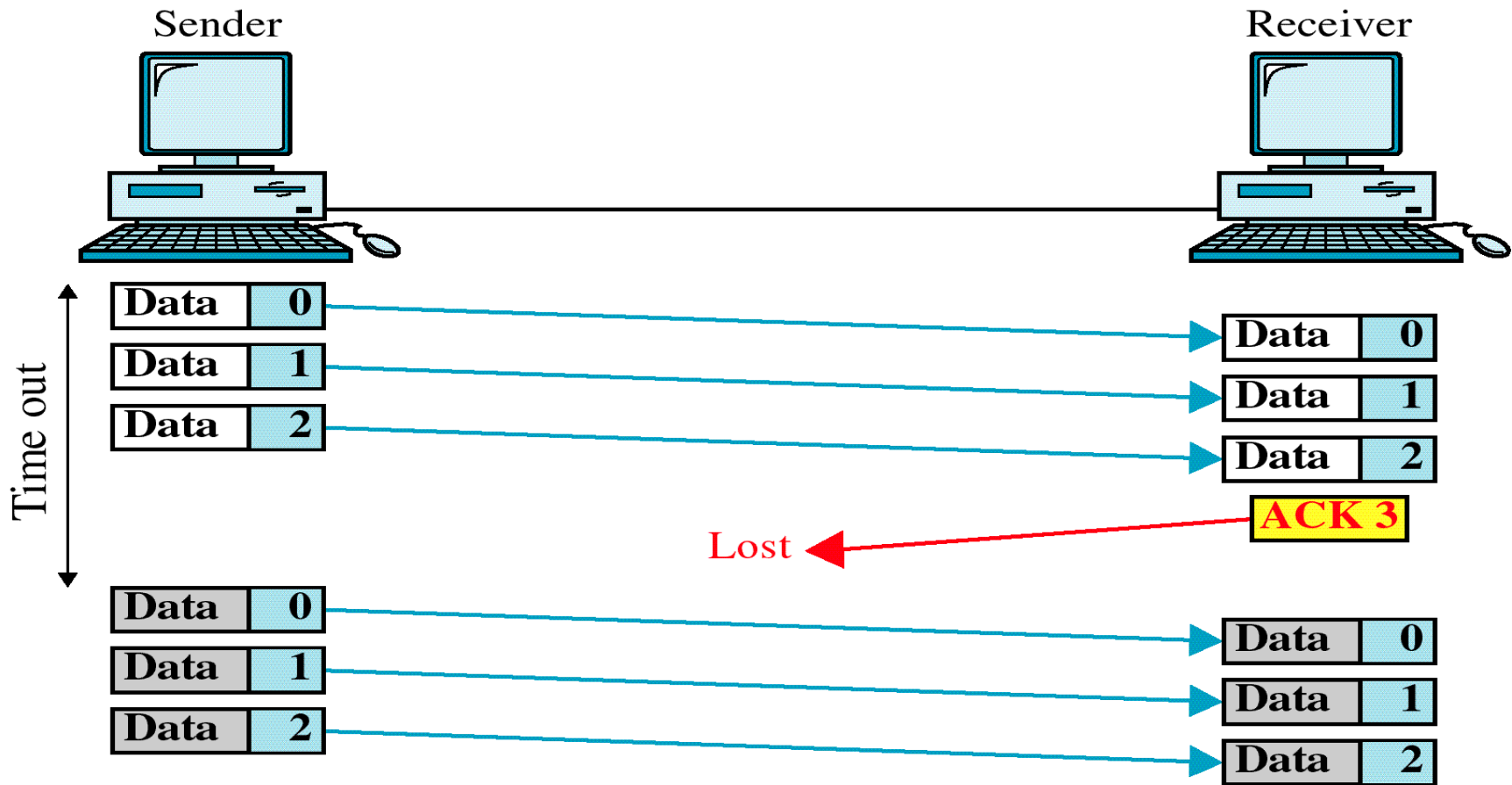

Go Back N Diagram

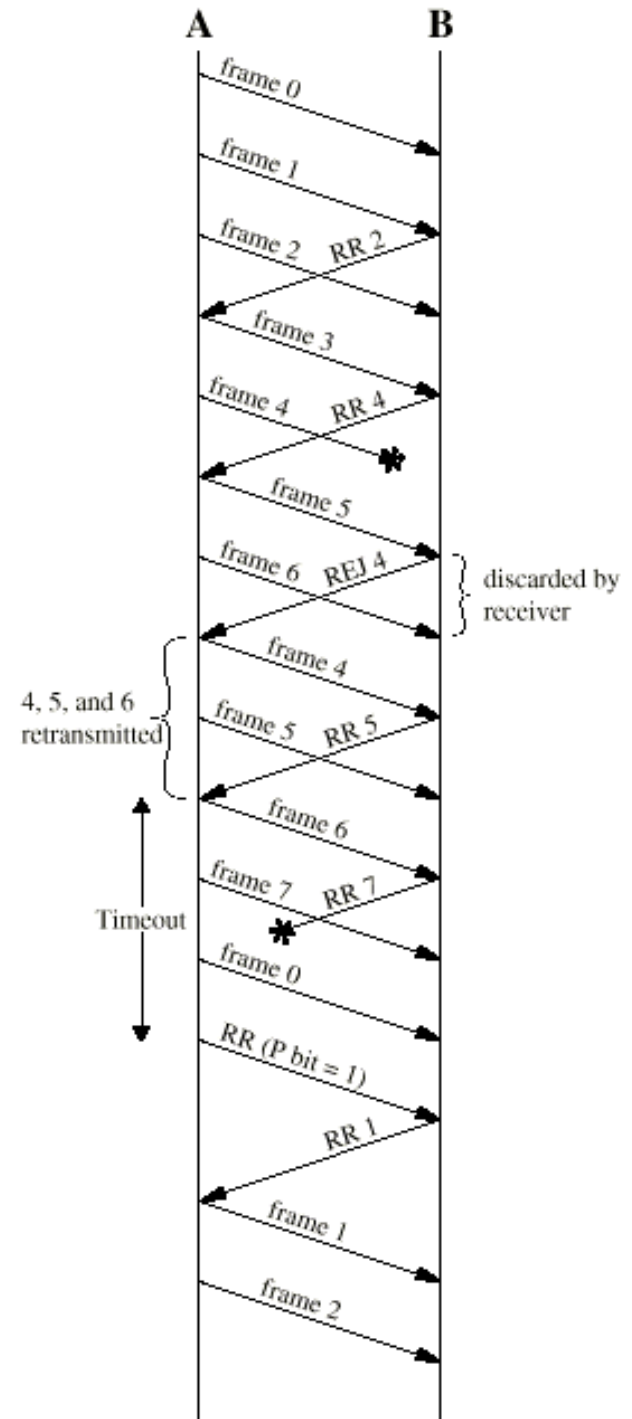

Selective Reject

- Also called selective retransmission
- Only rejected frames are retransmitted
- Subsequent frames are accepted by the receiver and buffered
- Minimizes retransmission
- Receiver must maintain large enough buffer
- More complex logging in transmitter

Selective-Reject Diagram

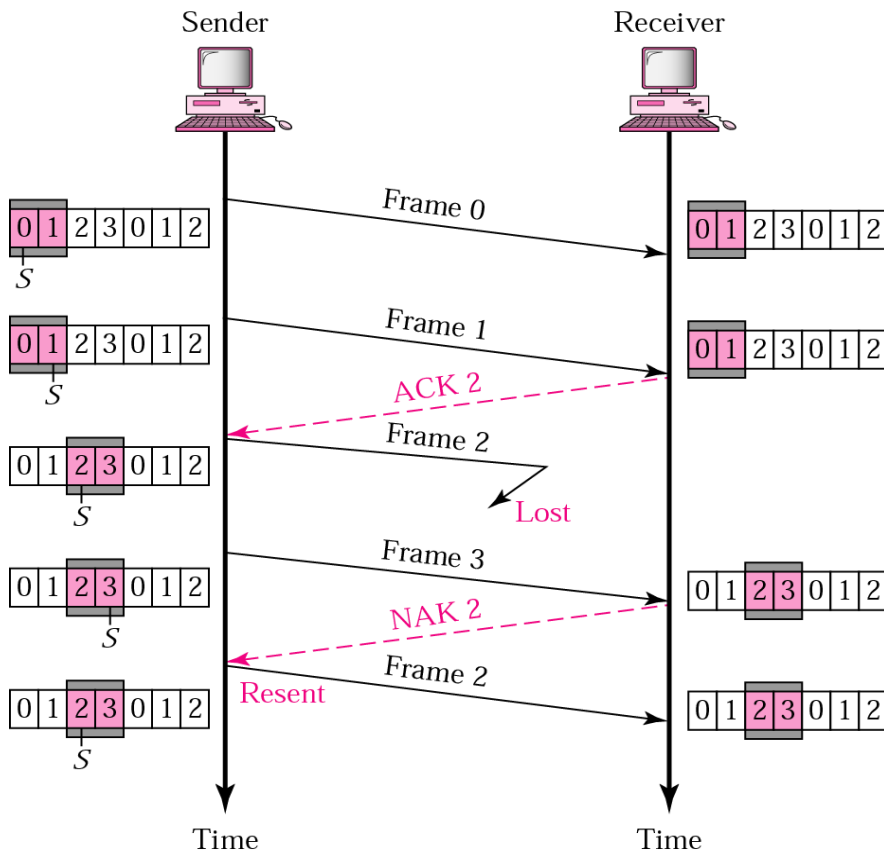

Winter 2012

SEG3155/CEG3185

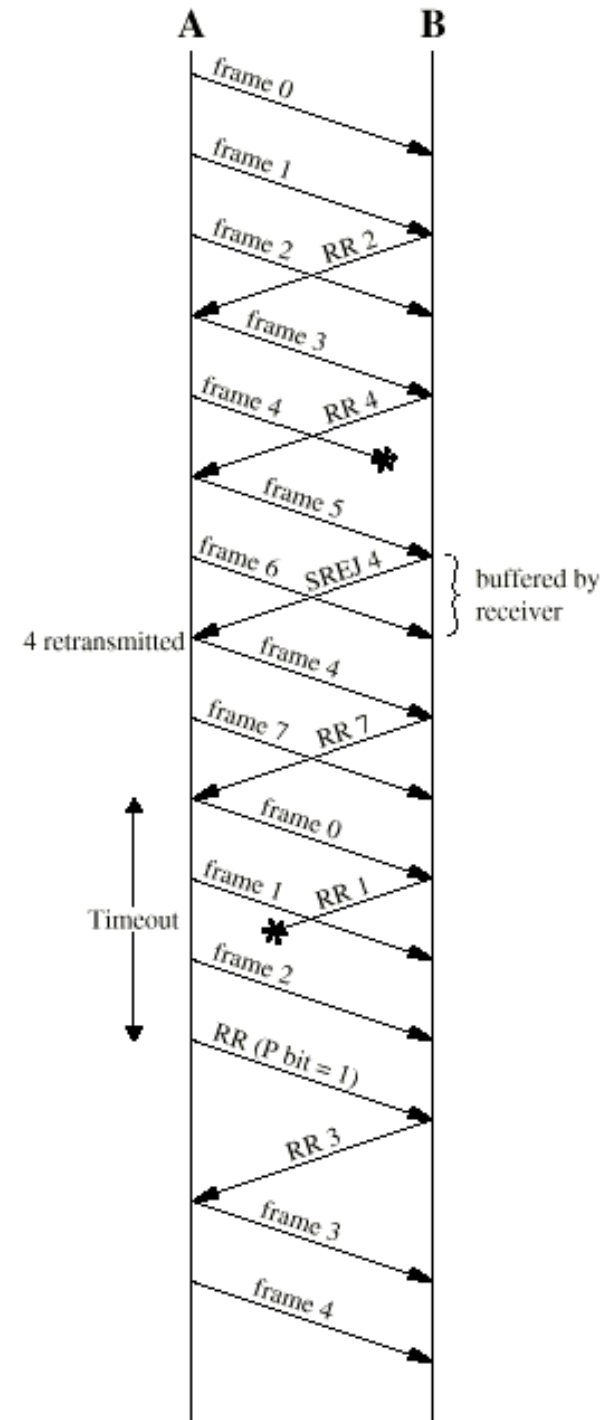

High-Level Data Link Control

- HDLC is an actual protocol designed to support both half-duplex and full-duplex communication
- Over point-to-point and multipoint links
- It implements the ARQ mechanisms.
- HDLC provides three modes of transmission NRM, ABM, and ARM.

HDLC Station Types

- Primary station
 - Controls operation of link
 - Frames issued are called commands
 - Maintains separate logical link to each secondary station
- Secondary station
 - Under control of primary station
 - Frames issued called responses
- Combined station
 - May issue commands and responses

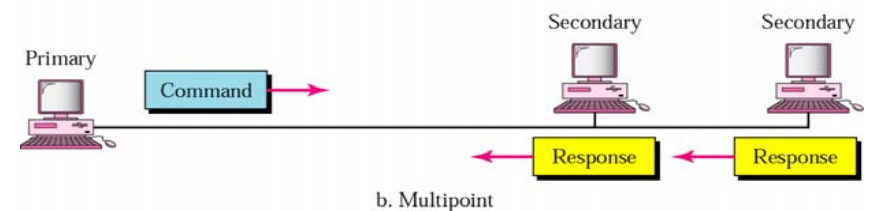
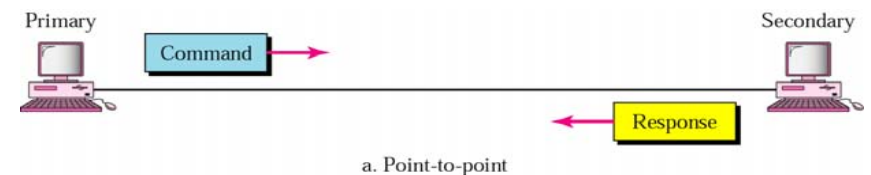

HDLC Link Configurations

- Unbalanced
 - One primary and one or more secondary stations
 - Supports full-duplex and half-duplex
- Balanced
 - Two combined stations
 - Supports full-duplex and half-duplex

HDLC Transfer Modes (1)

- Normal Response Mode (NRM)
 - Unbalanced configuration
 - Primary initiates transfer to secondary
 - Secondary may only transmit data in response to command from primary
 - Used on multi-drop lines
 - Host computer as primary
 - Terminals as secondary

HDLC Transfer Modes (2)

- Asynchronous Balanced Mode (ABM)
 - Balanced configuration
 - Either station may initiate transmission without receiving permission
 - Most widely used
 - No polling overhead

HDLC Transfer Modes (3)

- Asynchronous Response Mode (ARM)
 - Unbalanced configuration
 - Secondary may initiate transmission without permission from primary
 - Primary responsible for line
 - Rarely used

Frame Structure

- Synchronous transmission
- All transmissions in frames
- Single frame format for all data and control exchanges

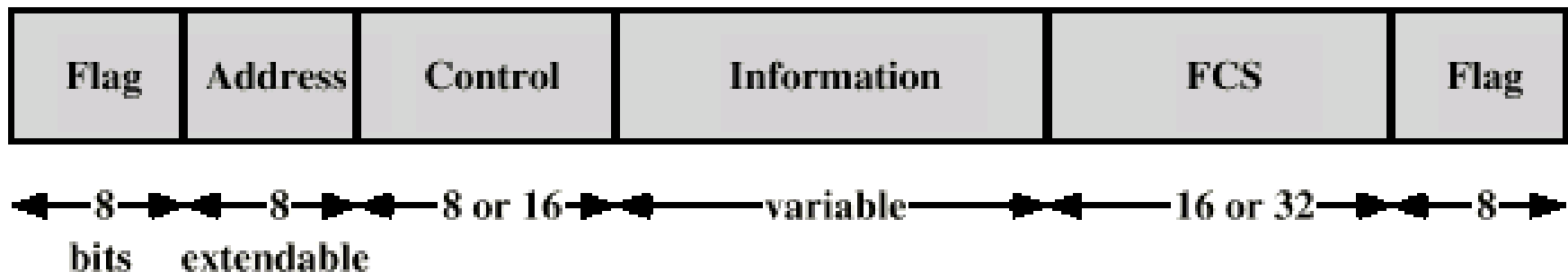

(a) Frame format

Flag Fields

- Delimit frame at both ends
- 01111110 (7E)
- May close one frame and open another
- Receiver hunts for flag sequence to synchronize
- Bit stuffing used to avoid confusion with data containing 01111110
 - 0 inserted after every sequence of five 1s
 - If receiver detects five 1s it checks next bit
 - If 0, it is deleted
 - If 1 and seventh bit is 0, accept as flag
 - If sixth and seventh bits 1, sender is indicating abort

Bit Stuffing

- Data transparency
- Example with possible errors

Original Pattern:

1111111111111011111101111110

After bit-stuffing

1111101111101101111101011111010

(a) Example

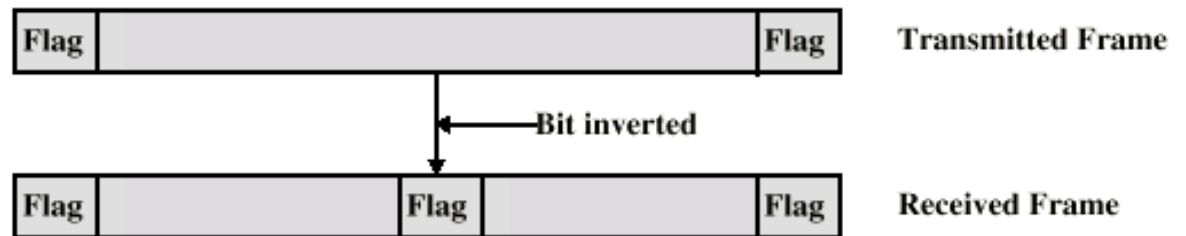

(b) An inverted bit splits a frame in two

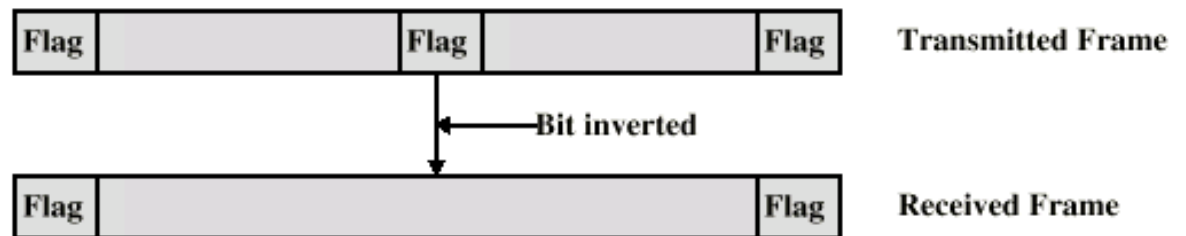

(c) An inverted bit merges two frames

Bit Stuffing and Removal

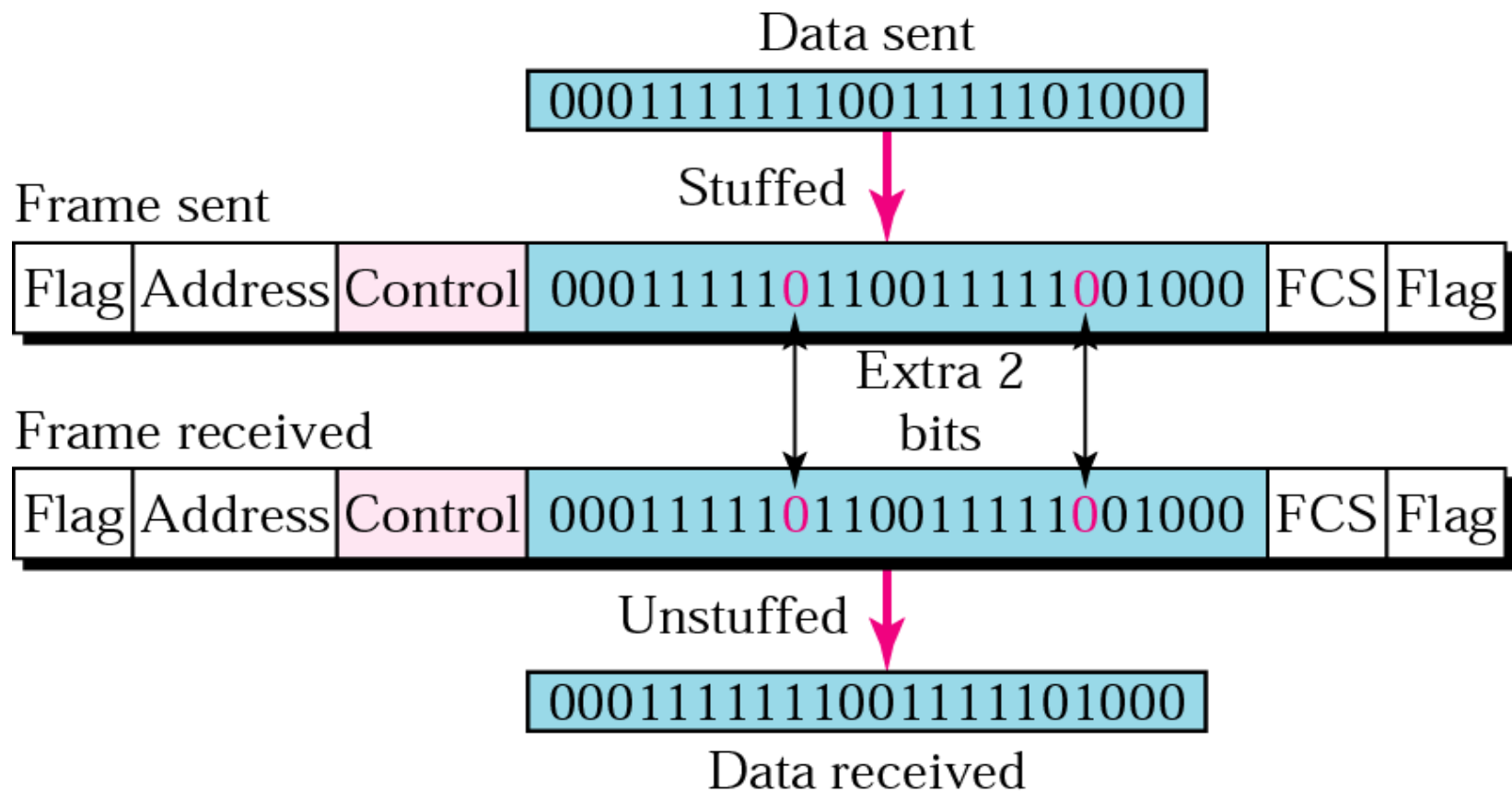

Bit Stuffing in HDLC

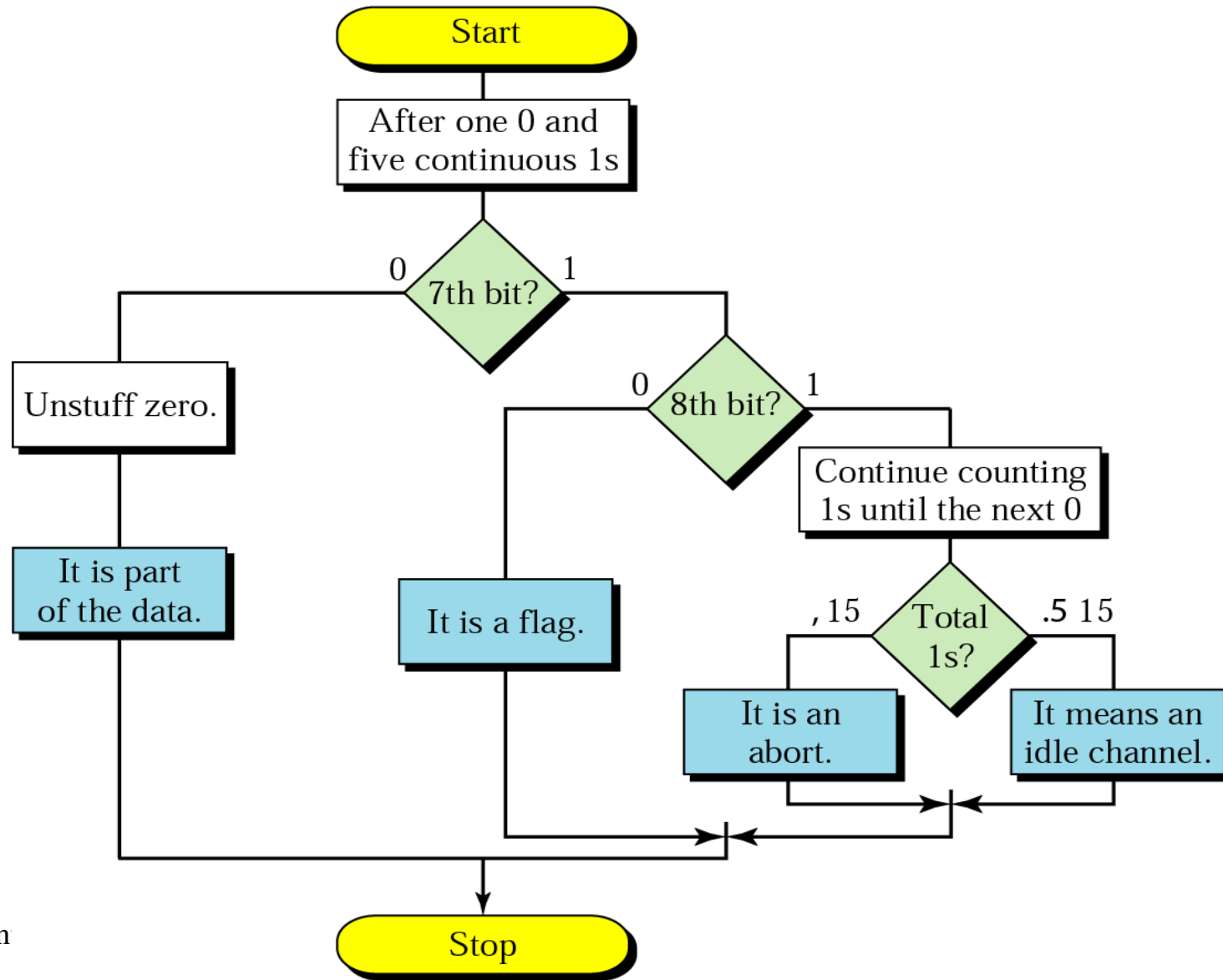

Address Field

- Identifies secondary station
- Usually 8 bits long
- May be extended to multiples of 7 bits
 - Leftmost bit of each octet indicates that it is the last octet (1) or not (0)
- All ones (11111111) is broadcast



(b) Extended Address Field

Control Field

- Different for different frame type
 - Information - data to be transmitted to user (next layer up)
 - Flow and error control piggybacked on information frames
 - Supervisory - ARQ when piggyback not used
 - Unnumbered - supplementary link control
- First one or two bits of control field identify frame type

Control Field Diagram

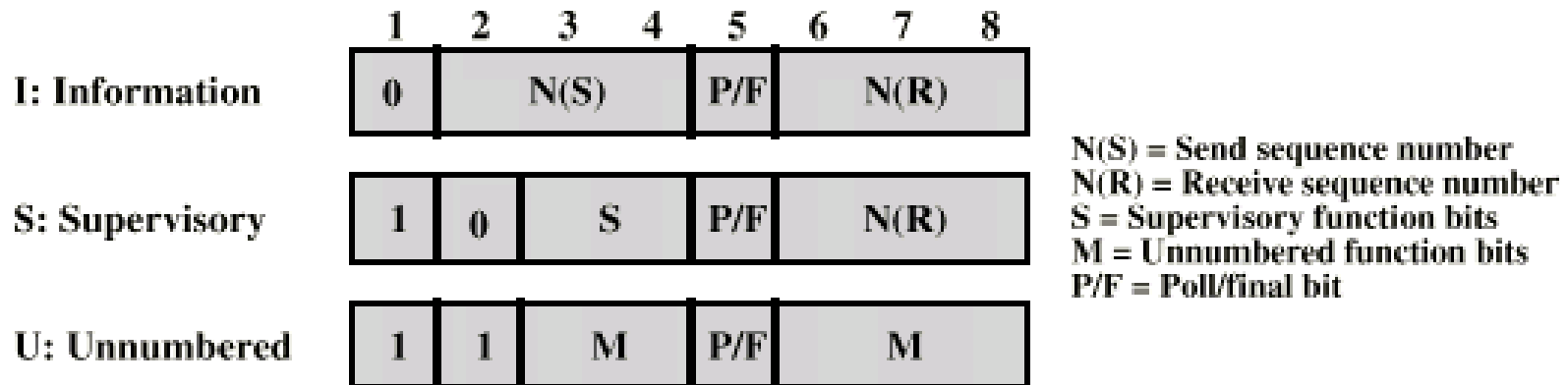

(c) 8-bit control field format

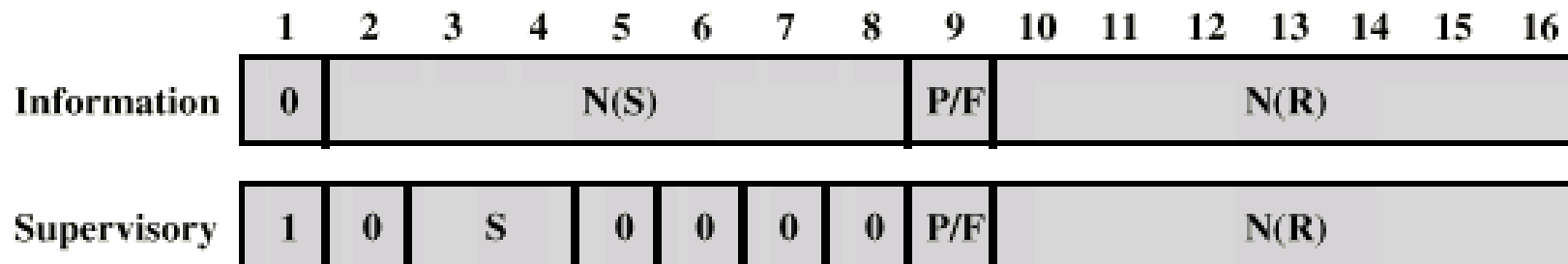

(d) 16-bit control field format

I-frame

- If the first bit of the control field is 0, this means the frame is an I-frame.
- $N(S)$
- P/F
- $N(R)$

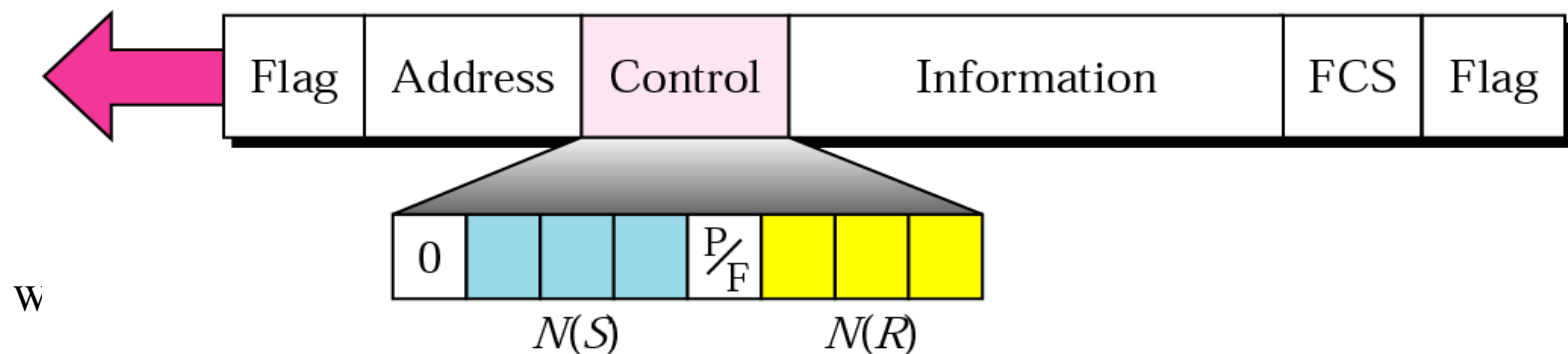

S-frame Control Field

- If the first 2 bits of the control field are 10, this means the frame is an S-frame.
- Code
 - RR
 - RNR
 - REJ
 - SREJ

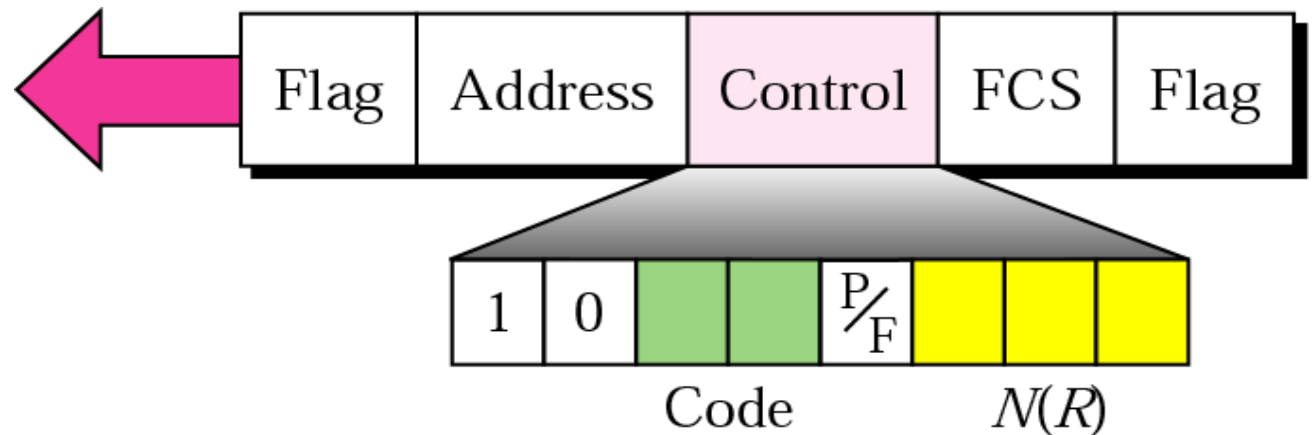

U-frame

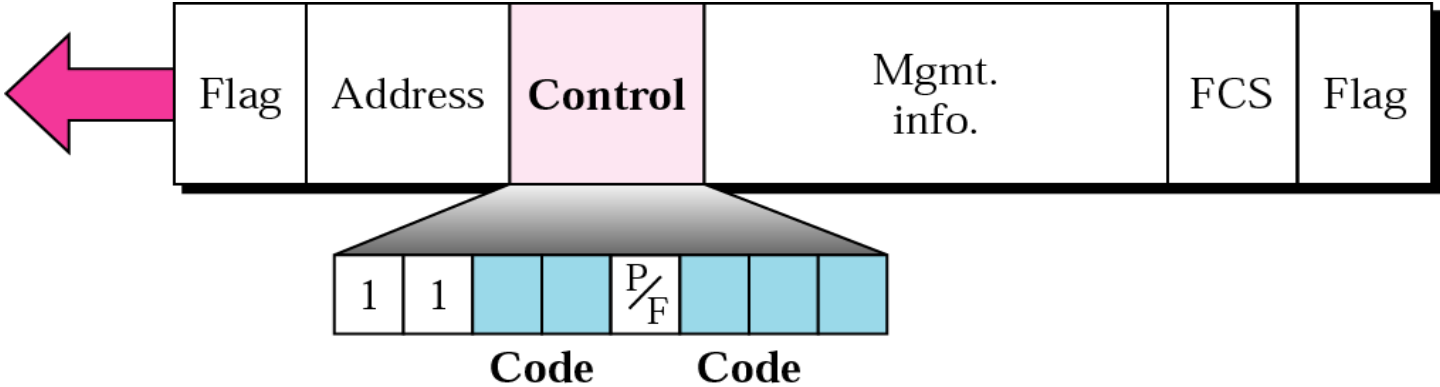

Code	Command	Response
00 001	SNRM	
11 011	SNRME	
11 100	SABM	DM
11 110	SABME	
00 000	UI	UI
00 110		UA
00 010	DISC	RD
10 000	SIM	RIM
00 100	UP	
11 001	RSET	
11 101	XID	XID
10 001		FRMR

HDLC Commands and Responses

Winter 2012

Table 7.1 HDLC Commands and Responses

Name	Command/ Response	Description
Information (I)	C/R	Exchange user data
Supervisory (S)		
Receive ready (RR)	C/R	Positive acknowledgment; ready to receive I-frame
Receive not ready (RNR)	C/R	Positive acknowledgment; not ready to receive
Reject (REJ)	C/R	Negative acknowledgment; go back N
Selective reject (SREJ)	C/R	Negative acknowledgment; selective reject
Unnumbered (U)		
Set normal response/extended mode (SNRM/SNRME)	C	Set mode; extended = 7-bit sequence numbers
Set asynchronous response/extended mode (SARM/SARME)	C	Set mode; extended = 7-bit sequence numbers
Set asynchronous balanced/extended mode (SABM, SABME)	C	Set mode; extended = 7-bit sequence numbers
Set initialization mode (SIM)	C	Initialize link control functions in addressed station
Disconnect (DISC)	C	Terminate logical link connection
Unnumbered Acknowledgment (UA)	R	Acknowledge acceptance of one of the set-mode commands
Disconnected mode (DM)	R	Responder is in disconnected mode
Request disconnect (RD)	R	Request for DISC command
Request initialization mode (RIM)	R	Initialization needed; request for SIM command
Unnumbered information (UI)	C/R	Used to exchange control information
Unnumbered poll (UP)	C	Used to solicit control information
Reset (RSET)	C	Used for recovery; resets N(R), N(S)
Exchange identification (XID)	C/R	Used to request/report status
Test (TEST)	C/R	Exchange identical information fields for testing
Frame reject (FRMR)	R	Report receipt of unacceptable frame

Poll/Final Bit

- Use depends on context
- Command frame
 - P bit
 - 1 to solicit (poll) response from peer
- Response frame
 - F bit
 - 1 indicates response to soliciting command

Information Field

- Only in information and some unnumbered frames
- Must contain integral number of octets
- Variable length

Frame Check Sequence Field

- FCS
- Error detection
- 16 bit CRC ($x^{16}+x^{12}+x^5+1$)
- Optional 32 bit CRC

HDLC Operation

- Exchange of information, supervisory and unnumbered frames
- Three phases
 - Initialization
 - Data transfer
 - Disconnect

Examples of Operation (1)

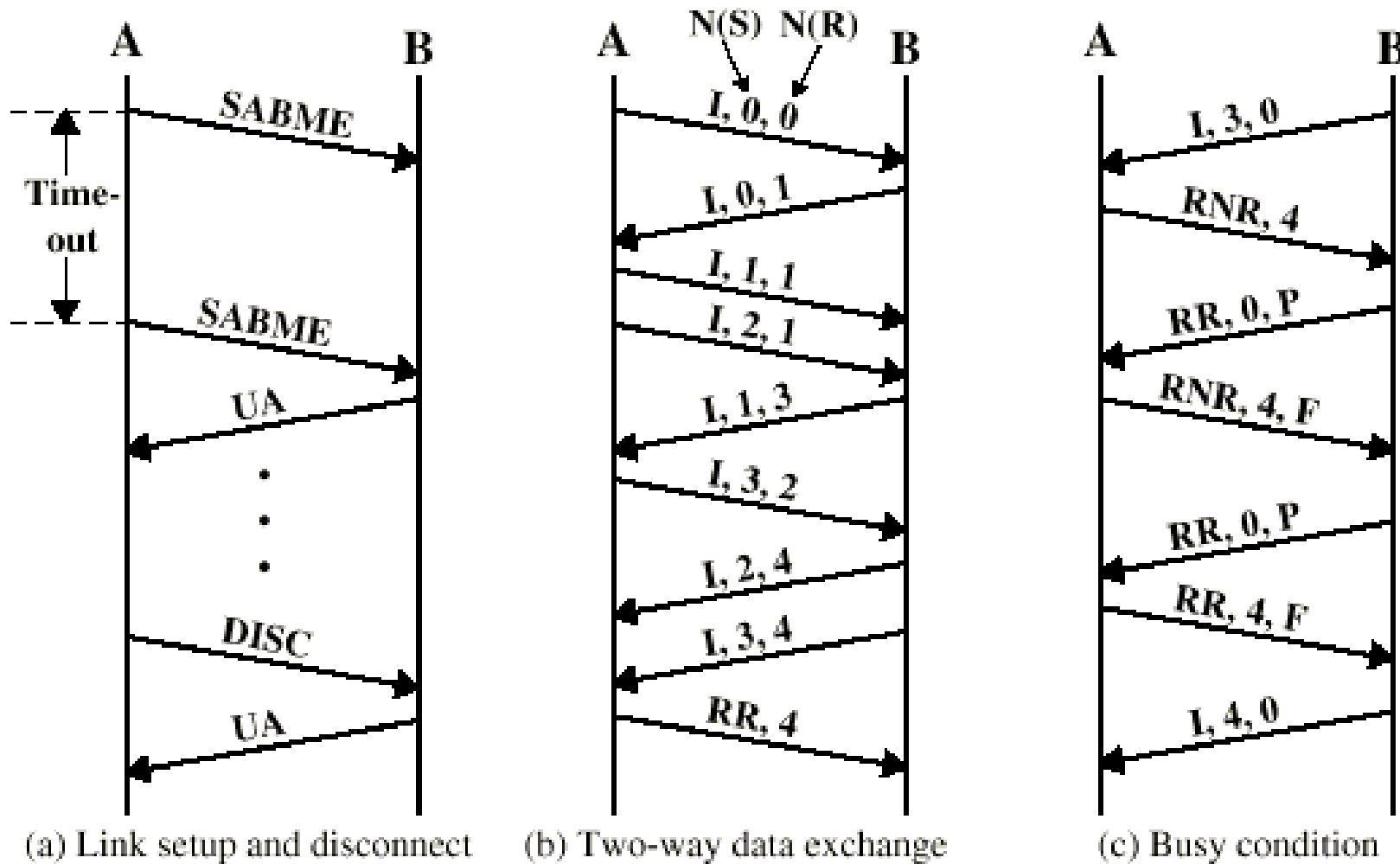

Examples of Operation (2)

