

# IR-UWB-Over-Fiber Systems Compatible With WDM-PON Networks

Shilong Pan, *Member, IEEE, Member, OSA*, and Jianping Yao, *Senior Member, IEEE, Fellow, OSA*

**Abstract**—Integrating an ultrawideband-over-fiber (UWBoF) system into a wavelength division multiplexing passive optical network (WDM-PON) is of great interest due to the high potential to provide high data-rate and flexible wired and wireless services with a favorable cost. In this paper, we perform a comprehensive study on an impulse radio UWBoF system compatible with the WDM-PON architecture implemented based on a photonic microwave bandpass filter. The bandpass filter is a two-tap delay-line filter implemented using either a polarization modulator (PoM) or a phase modulator (PM), which is used to simultaneously shape an electrical Gaussian-like pulse to an optical UWB pulse and reduce the out-band noise and interference. The features of the photonic microwave bandpass filters are theoretically studied. The photonic microwave bandpass filter based on a PoM would produce a chirp-free UWB signal, while the one based on a PM would generate a UWB signal that is insensitive to fiber dispersion. A single-channel UWBoF system with ON-OFF keying, biphasic modulation, and pulse-position modulation without and with time hopping are experimentally studied. The experimental results agree well with the theoretical predictions. A four-channel UWBoF broadcasting network as well as a hybrid WDM-PON network to provide both wireless and wired services is also experimentally investigated. Results show that a conventional WDM-PON network could be easily upgraded to provide UWB services by incorporating the proposed photonic microwave bandpass filter.

**Index Terms**—External modulation, microwave photonics, optical fiber, photonic microwave bandpass filter, power spectral density (PSD), radio over fiber, ultrawideband (UWB).

## I. INTRODUCTION

THE future wireless local area networks and wireless personal-area networks require a low complexity, low cost, low power consumption, and high data-rate wireless connectivity. The potential of these networks, however, is restricted by the reality of radio system engineering, where very limited free spectrum resources are available below 10 GHz. Ultrawideband (UWB), which optimally shares the spectrum resources with existing radio communications systems rather than looking for new spectral bands, is recognized as a promising solution to provide high data-rate wireless services [1]–[4]. In 2002, the U.S. Federal Communications Commission (FCC) approved unlicensed use of a spectral band from 3.1 to 10.6 GHz

with a transmitted power spectral density (PSD) of less than  $-41.3$  dBm/MHz for wireless communications. Two major techniques for UWB communications, namely multiband orthogonal frequency division multiplexing UWB and impulse radio UWB (IR-UWB) systems were then developed. Since the impulse radio has the advantages such as carrier free and simple implementation, we only consider IR-UWB in this work. Due to the low PSD of the transmitted signal, the typical communication distance of a UWB system is limited to a few meters to tens of meters. To increase the area of coverage and to offer the availability of uninterrupted service across different networks, UWB over fiber (UWBoF) technology is proposed [5]. Different UWBoF systems have been reported recently [6]–[15]. To practically deploy a UWBoF system, it is of great importance to reduce the cost of the system. A solution is to integrate UWBoF systems into the current or future wired optical access networks [10], [11].

Concerning the wired optical access networks, Gigabit passive optical network (GPON) according to ITU-T G.984 [16] has been widely deployed in parts of the U.S. and Europe. Meanwhile, Ethernet PON (EPON) according to the Ethernet-First-Mile standard or IEEE 802.3 ah [17] is broadly deployed in Japan and Korea. However, both GPON and EPON are based on time-division multiple access (TDMA) technology, providing services to  $N$  users by use of passive  $1:N$  power splitters with an aggregate bit rate, so they cannot keep up with the requirements of future access network evolution regarding aggregated bandwidth, attainable reach, and allowable power budget. Therefore, there is a worldwide consensus that the current TDMA passive optical network (i.e., EPON and GPON) would evolve toward wavelength division multiplexing PON (WDM-PON) [18]–[20]. Under this background, it is of great interest to integrate a UWBoF system into a WDM-PON network.

On the other hand, photonic microwave filters have attracted considerable interests recently [21], [22]. Thanks to the advantages such as high speed, immunity to electromagnetic interference, low loss, light weight, and excellent tunability and reconfigurability, photonic microwave filters can be employed for advanced signal processing including in a UWBoF system to shape a Gaussian pulse to a Gaussian monocycle or doublet, and to simultaneously reduce the out-band noise and interferences. In addition, the photonic microwave filter can be reconfigured to have an optimal frequency response so as to produce a power-efficient UWB signal that best fits the spectral mask specified by the FCC. To implement UWB pulse shaping, a photonic microwave filter must be a bandpass filter with a passband that covers a frequency range from 3.1 to 10.6 GHz. However, most of the reported microwave photonic filters are operating in the incoherent regime, in which only the intensities of the

Manuscript received February 24, 2011; revised June 23, 2011; accepted August 11, 2011. Date of publication August 18, 2011; date of current version September 28, 2011. This work was supported by the Natural Sciences and Engineering Research Council of Canada.

The authors are with the Microwave Photonics Research Laboratory, School of Information Technology and Engineering, University of Ottawa, Ottawa, ON K1N 6N5, Canada (e-mail: pans@ieee.org; jpyao@site.uOttawa.ca).

Color versions of one or more of the figures in this paper are available online at <http://ieeexplore.ieee.org>.

Digital Object Identifier 10.1109/JLT.2011.2165275

time-delayed optical signals are manipulated. Therefore, all tap coefficients are positive or a special design has to be incorporated to generate negative tap coefficients. Several approaches have been proposed to produce photonic microwave bandpass filters for UWB pulse shaping. Examples include the methods based on differential detection [23], [24], wavelength conversion based on cross-gain modulation in a semiconductor optical amplifier (SOA) or a fiber-optical parametric amplifier [25], [26], biasing two Mach-Zehnder modulators (MZMs) at the complementary slopes [27], and polarization modulation [12], [28]. However, the employment of high-performance balanced photodetectors (PDs) would increase greatly the cost of an optical network unit (ONU) at the user end [23], [24]. In addition, a photonic microwave bandpass filter based on two or more laser sources [25]–[28] is not compatible with the WDM-PON architecture because the wavelengths are the key resource for WDM-PONs.

Recently, two techniques to implement a photonic microwave bandpass filter based on a polarization modulator (PolM) and a phase modulator (PM) have been proposed to generate optical UWB signals [12], [29]. A photonic microwave bandpass filter based on a PolM can produce chirp-free UWB signals [12], which have a good tolerance to fiber dispersion. Meanwhile, a photonic microwave bandpass filter based on a PM has a constant frequency response for different distribution distances. Therefore, optical UWB signals generated using a PM-based microwave filter also have a good tolerance to fiber dispersion [29]. However, in [12] and [29], only ON–OFF keying (OOK) modulation scheme was investigated. The major limitation of using OOK in a UWB communication system is the presence of multipath effects, in which echoes of the original pulses make it difficult to determine the absence of a pulse (i.e., “0”). In addition, OOK is a binary modulation method which cannot be extended to an  $M$ -ary modulation. Therefore, it is of great interest to implement other modulation schemes, such as pulse-position modulation (PPM), biphase modulation (BPM, also known as pulse-polarity modulation) in the optical domain. In addition, the possibility to integrate a UWBoF system based on a PolM-based or PM-based photonic microwave bandpass filter into a WDM-PON network is not investigated.

In this paper, we present a comprehensive study on the PolM-based and PM-based photonic microwave bandpass filters for optical UWB signal generation and distribution. In addition to the theoretical and experimental investigation on the performance of the optical UWB generators, we present in this paper: 1) the generation of optical UWB signals with OOK, BPM, and PPM modulation schemes based on a photonic microwave bandpass filter; 2) the generation of UWB signals at multiple wavelengths using a single photonic-microwave-filter-based UWB generator; and 3) multiple-channel UWBoF systems using WDM technology incorporating the PolM-based or PM-based microwave filters. The integration of the proposed solutions into a WDM-PON is feasible because both the PolM-based and PM-based microwave filters utilize a single narrow linewidth laser source and the operations are independent of the wavelength of the laser source. To the best of our knowledge, this is the first time such a WDM-UWBoF system is experimentally implemented.

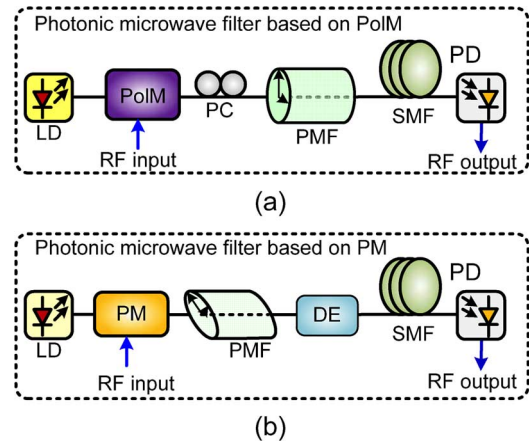

Fig. 1. Schematic diagrams of the photonic microwave bandpass filters based on (a) a PolM and (b) a PM. LD: laser diode; PolM: polarization modulator; PC: polarization controller; PMF: polarization-maintaining fiber; SMF: single-mode fiber; PD: photodetector; PM: phase modulator; DE: dispersive element.

The paper is organized as follows. In Section II, we study theoretically the frequency responses of the PolM- and PM-based photonic microwave bandpass filters incorporating a length of single-mode fiber (SMF) for signal transmission. In Section III, optical UWB signals with OOK, BPM, and PPM are experimentally generated. The transmission performance of these UWB signals over an SMF is studied by measuring the eye diagrams, electrical spectra, and receiver sensitivities. In Section IV, a UWBoF system integrated into a WDM-PON network is investigated. A WDM UWBoF system designed to provide four-channel broadcasting service as well as a hybrid WDM-PON network to provide both wireless and wired services are experimentally studied. A conclusion is drawn in Section V.

## II. PHOTONIC MICROWAVE BANDPASS FILTER DESIGN

Fig. 1 shows the schematic diagrams of two photonic microwave bandpass filters implemented based on a PolM and a PM. The characteristics of the photonic microwave bandpass filters without fiber distribution have been theoretically and experimentally studied in [30] and [31]. In this section, we will investigate the frequency responses of the two photonic microwave bandpass filters incorporating a length of SMF for signal transmission.

### A. Photonic Microwave Bandpass Filter Based on a PolM

Fig. 1(a) shows a PolM-based photonic microwave bandpass filter. It consists of a laser diode (LD), a PolM, a polarization controller (PC), a section of polarization-maintaining fiber (PMF), a length of SMF, and a PD. The PolM is a special PM that can support both TE and TM modes with, however, opposite phase modulation indices [32]. When a linearly polarized incident light that is oriented at an angle of  $45^\circ$  to one principal axis of the PolM, two complementary phase-modulated signals are generated along the two principal axes. The normalized optical fields at the output of the PolM along the two principal axes can be expressed as

$$\begin{bmatrix} E_x(t) \\ E_y(t) \end{bmatrix} = e^{j\omega_c t} \begin{bmatrix} e^{j\beta\phi(t)/2} \\ e^{-j\beta\phi(t)/2} \end{bmatrix} \quad (1)$$

where  $\omega_c$  is the angular frequency of the optical carrier,  $\beta$  is the phase modulation index, and  $\phi(t)$  is the modulating signal.

The phase-modulated signals are then sent to a PMF-based delay line through a PC, which is used to align the principal axes of the PolM to have an angle of  $\alpha$  with one principal axis of the PMF. The optical fields at the output of the PMF along the two principal axes of the PMF can be written as (2), shown at the bottom of the page, where  $\phi_0$  is a static phase shift introduced by the PC,  $\tau$  denotes the differential group delay (DGD) of the PMF. If the optical signals expressed in (2) are sent to a PD for square-law detection, the obtained photocurrent is

$$\begin{aligned} I &\propto |E'_x(t)|^2 + |E'_y(t)|^2 \\ &= 2 + \sin 2\alpha \{ \cos[\beta\phi(t) + \phi_0] - \cos[\beta\phi(t + \tau) + \phi_0] \}. \end{aligned} \quad (3)$$

If  $\phi_0 = \pi/2$  and  $\alpha = \pm\pi/4$ , the ac component in (3) can be then rewritten as

$$I_{ac} \propto \pm \{ \sin[\beta\phi(t)] - \sin[\beta\phi(t + \tau)] \}. \quad (4)$$

For small-signal modulation,  $\beta$  is small, we have  $\sin[\beta\phi(t)] \approx \beta\phi(t)$ , then (4) is approximated

$$I_{ac} \propto \pm\beta[\phi(t) - \phi(t + \tau)]. \quad (5)$$

As can be seen from (5), the system is equivalent to a two-tap photonic microwave delay-line filter with two coefficients of  $(1, -1)$ . The magnitude frequency response of the photonic microwave bandpass filter is then given by

$$|H_1(f)| \propto |\sin(\pi f\tau)|. \quad (6)$$

Substituting  $\phi_0 = \pi/2$  and  $\alpha = \pm\pi/4$  back into (2) and applying the small-signal modulation assumption, we have (7), shown at the bottom of the page. From (7), we can see that both  $E'_x$  and  $E'_y$  have a fixed phase term. Therefore, the complementary intensity-modulated signals at the output of the PolM are chirp free. According to [33], when a chirp-free signal is transmitting through a length of SMF, the frequency response is given by

$$|H_2(f)| = \left| \cos \left( \frac{\pi DL\lambda^2 f^2}{c} \right) \right| \quad (8)$$

where  $D$  is the dispersion parameter,  $L$  is the length of SMF,  $\lambda$  is the wavelength of the optical carrier, and  $c$  is the speed of light in vacuum.

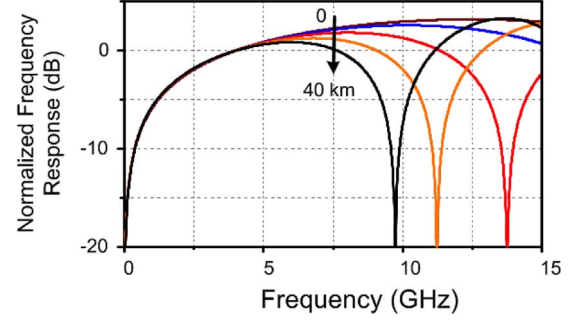

Fig. 2. Theoretical frequency response of the photonic microwave bandpass filter based on a PolM incorporating a length of SMF with a length of 0, 10, 20, or 30 km.

Then, the overall transfer function of the photonic microwave bandpass filter incorporating a length of SMF can be written as

$$|H(f)| \propto \underbrace{|\sin(\pi f\tau)|}_{|H_1(f)|} \cdot \underbrace{\left| \cos \left( \frac{\pi DL\lambda^2 f^2}{c} \right) \right|}_{|H_2(f)|}. \quad (9)$$

As can be seen from (9), the overall transfer function is the multiplication of a bandpass transfer function  $|H_1(f)|$  and a low-pass transfer function  $|H_2(f)|$ . The bandpass filtering is resulted from the PMF which introduces a time-delay difference between the two complementary intensity-modulated signals, while the low-pass filtering is obtained by chromatic dispersion (CD) in the SMF which introduces a power penalty to the intensity-modulated optical microwave signals.  $|H_1(f)|$  has a notch at  $f_0 = 0$  and a second notch at  $f_1 = 1/\tau$ .  $|H_2(f)|$  has the first notch at

$$f_2 = \sqrt{\frac{c}{2DL\lambda^2}}. \quad (10)$$

Fig. 2 shows the frequency response of the PolM-based photonic microwave bandpass filter incorporating a length of SMF with a length of 0, 10, 20, 30, or 40 km (the dispersion parameter of the SMF is 16.5 ps/nm/km) and a PMF with a DGD of 40 ps. In practice, the PSD of the UWB signal generated by the filter would be controlled to best fit the FCC-specified spectral mask before being emitted to free space, so the peak PSD should be fixed at  $-41.3$  dBm/MHz. Since the peak spectral lines of a typical UWB monocycle signals are at around 4 GHz [23]–[28], in Fig. 2 the frequency responses are normalized to let the transmittance at 4 GHz equal to 0 dB. The 3 dB passband decreases from 16.6 to 6.36 GHz when the length of the SMF increases

$$\begin{aligned} \begin{bmatrix} E'_x(t) \\ E'_y(t) \end{bmatrix} &= \begin{bmatrix} \cos \alpha \cdot E_x(t) + \sin \alpha \cdot E_y(t) e^{-j\phi_0} \\ \cos \alpha \cdot E_x(t + \tau) - \sin \alpha \cdot E_y(t + \tau) e^{-j\phi_0} \end{bmatrix} \\ &\propto \begin{bmatrix} \cos \alpha \cdot e^{j\beta\phi(t)/2} + \sin \alpha \cdot e^{-j[\beta\phi(t)/2 + \phi_0]} \\ e^{j\omega_c\tau} \{ \cos \alpha \cdot e^{j\beta\phi(t+\tau)/2} - \sin \alpha \cdot e^{-j[\beta\phi(t+\tau)/2 + \phi_0]} \} \end{bmatrix} \end{aligned} \quad (2)$$

$$\begin{bmatrix} E'_x \\ E'_y \end{bmatrix} \propto \begin{bmatrix} (1 \mp j) \{ \cos[\beta\phi(t)/2] + \sin[\beta\phi(t)/2] \} \\ e^{j\omega_c\tau} (1 \pm j) \{ \cos[\beta\phi(t + \tau)/2] + \sin[\beta\phi(t + \tau)/2] \} \end{bmatrix} \quad (7)$$

from 0 to 40 km. The bandwidth decreasing is originated from the low-pass filtering due to the CD induced power penalty. The transmission over a 10, 20, and 30 km SMF would introduce a power penalty of 0.54, 2.17, and 7.55 dB at the frequency of 10.6 GHz as compared with the case without SMF transmission. But the frequency from 0–7.5 GHz is almost not affected by the CD. Since the major power of a UWB Gaussian monocycle is around 3–7.5 GHz, UWB signals generated by a PolM-based photonic microwave bandpass filter can be distributed over an SMF with a length of more than 20 km with negligible power penalty. However, for the case when a 40 km SMF is incorporated, the power penalty exceeds 2 dB at 7.5 GHz. As a result, dispersion compensation must be applied when the length of SMF is greater than 40 km.

### B. Photonic Microwave Bandpass Filter Based on a PM

The schematic diagram of the photonic microwave bandpass filter based on a PM is shown in Fig. 1(b). It consists of an LD, a PM, a section of PMF, a dispersive element (DE), a length of SMF, and a PD. If the extraordinary axis of the PM is aligned to have an angle of 45° to the principal axes of the PMF, by using a similar mathematical treatment as used for obtaining (9), we can obtain the magnitude frequency response of the photonic microwave bandpass filter [31], written as

$$|H(f)| = \underbrace{|\cos(\pi f \tau)|}_{|H_1(f)|} \cdot \underbrace{\left| \sin \left( \frac{\pi(\chi + DL)\lambda^2 f^2}{c} \right) \right|}_{|H_2(f)|} \quad (11)$$

where  $\chi$  is the dispersion of the DE.

Again, the overall transfer function is a multiplication of a low-pass transfer function  $|H_1(f)|$  and a bandpass transfer function  $|H_2(f)|$ .  $|H_1(f)|$  is resulted from the PMF which introduces a time-delay difference  $\tau$  between the two orthogonally polarized modes, and it has a notch at  $f_0 = 1/(2\tau)$ .  $|H_2(f)|$  is obtained when the phase-modulated signal is undergoing CD in the DE and it has a notch at  $f_1 = 0$ . The second notch of  $|H_2(f)|$  is located at

$$f_2 = \sqrt{\frac{c}{(\chi + DL)\lambda^2}}. \quad (12)$$

With the DGD of the PMF  $\tau = 40$  ps and the CD of the DE  $\chi = -609$  ps/nm, we have the theoretical frequency responses of the PM-based filter incorporating an SMF for signal transmission, as shown in Fig. 3. The 3 dB passband increases from 6.54 to 6.87 GHz when the length of the SMF increases from 0 to 30 km. The transmission of 10, 20, and 30 km SMF introduces a power variation of less than 1.3 dB at the frequency of 10.6 GHz. In addition, the frequency response in the frequency range from 3.1 to 10.6 GHz has an almost identical profile, showing that the system has a good tolerance to fiber dispersion. This is because the frequency at the first notch of the PMF-induced low-pass filter (LPF) is smaller than that at the second notch of the dispersion-induced bandpass filter. Thus, the upper bound of the filter is governed by the first notch determined by  $\tau$ . Since  $\tau$  is not changed, the upper bound will not change. On the other hand, the dispersion will not significantly affect the frequency response at low frequencies. As a result, the frequency response

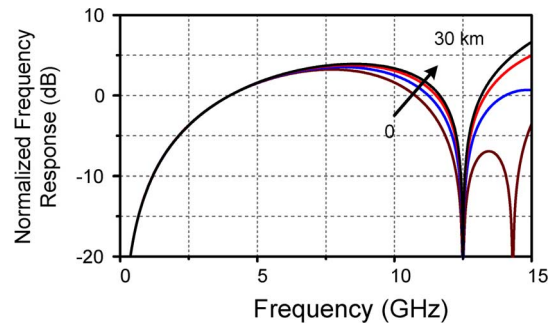

Fig. 3. Theoretical frequency response of the photonic microwave bandpass filter based on a PM when the length of the SMF is 0, 10, 20 or 30 km.

in the frequency range of interest has a profile that is independent of the SMF length. Therefore, optical UWB signals generated by a PM-based photonic microwave bandpass filter should also have a good tolerance to fiber dispersion. This feature is highly desirable for a UWBoF system with a fiber transmission link connecting the center office (CO) with an ONU. It should be noted that the peak transmittance of the filter is different for different lengths of the SMF, which means an ONU located at a different place with a different distance to the CO would receive UWB signals with different powers. This problem can be solved by employing automatic gain control (AGC), as it is always employed in a practical wireless network. However, when the length of the SMF is longer than 50 km, the peak transmittance of the filter in 0–10.6 GHz is more than 15 dB lower than that of the case without SMF transmission. An AGC with a large dynamic range is thus required, which may increase greatly the cost of the entire system.

As compared with the frequency response of the PolM-based photonic microwave bandpass filter, the filter based on a PM has a smaller transmittance in the frequency range of 0–3.1 GHz, which is also desirable for a UWBoF system.

### III. SINGLE-CHANNEL UWBOF SYSTEM

An experiment is performed based on the experimental setup shown in Fig. 4(a) to investigate the single-channel UWBoF system based on a photonic microwave bandpass filter incorporating an SMF for signal transmission. Both PolM- and PM-based photonic microwave bandpass filters are implemented based on the diagrams shown in Fig. 1. The parameters of the major devices in the photonic microwave bandpass filters are as follows: the bandwidths of the PM (JDS Uniphase) and the PolM (Versawave Technologies) are 20 and 40 GHz, respectively; the PD has a 3 dB bandwidth of 45 GHz and a responsivity of 0.4 A/W; the DGD of the PMF is about 40.1 ps; and the DE is a length of DCF (FSC-DCM-013C) with a dispersion value of  $-609$  ps/nm. Although a 45 GHz PD, a 20 GHz PM, and a 40 GHz PolM are used in the experiment, the system only requires devices with a bandwidth of less than 10.6 GHz.

A Gaussian-like pulse train generated by an arbitrary wave generator (AWG, Tektronix AWG7102) is applied to the photonic microwave bandpass filter via the RF port of the PolM or the PM depending on which type of the photonic microwave bandpass filter is used. The pulse shape is close to a Gaussian



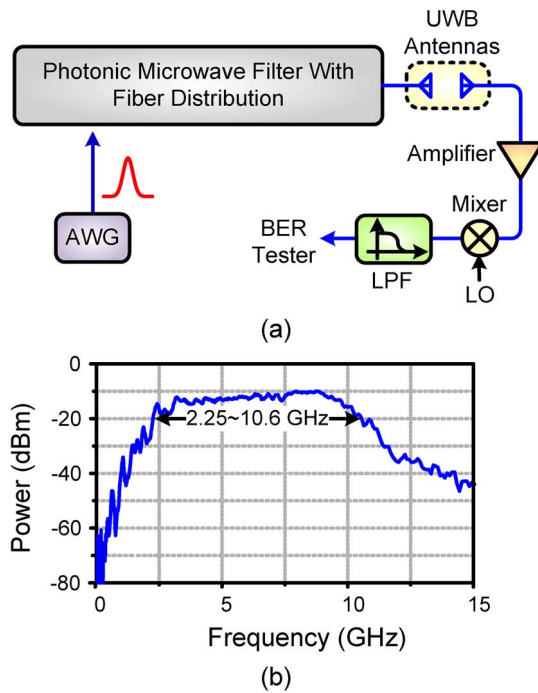

Fig. 4. (a) Experiment setup of the single-channel UWBoF system based on the photonic microwave filter. (b) Power frequency response of the antennas pair. AWG: arbitrary wave generator; LO: local oscillator; LPF: low-pass filter.

with a full-width at half-maximum of about 104 ps and a repetition rate of 1.25 GHz. The Gaussian-like pulse train is coded in the AWG with a  $2^{15} - 1$  pseudorandom bit sequence (PRBS) pattern. At the output of the photonic microwave bandpass filter, a UWB pulse train with data modulation at 1.25 Gb/s is obtained.

To evaluate the transmission performance, a length of SMF is incorporated in the photonic microwave bandpass filter for signal transmission. The generated UWB signal after the PD detection is emitted to free space through a UWB omnidirectional antenna (Skycross SMT-3TO10M-A). At the UWB receiver, the radiated UWB signal is received by another similar antenna and amplified by a wideband electrical amplifier (EA, DC-12.5 GHz, 25 dB gain). The signal from the amplifier is mixed at an electrical mixer with a local oscillator signal at 2.5, 3.75, 5, 6.25, or 7.5 GHz followed by an LPF (3 dB bandwidth of 1.2 GHz), to downconvert the data signal to the baseband. At the output of the LPF, the received baseband signal is introduced to a bit-error-rate (BER) tester for BER measurements. Since the UWB receiver has a high receiver sensitivity and the gain of the EA is limited, the antennas are placed in their peak radiation direction in the azimuth plane with a distance of 5 cm to avoid large wireless transmission loss. The power frequency response of the antennas pair is shown in Fig. 4(b). The 10 dB bandwidth of the antennas pair is about 8.35 GHz (2.25–10.6 GHz). The waveforms (or eye diagrams) are observed by a high-speed sampling oscilloscope (Agilent 86116A) and the spectra are measured by an electrical spectrum analyzer (Agilent E4448A).

Since the photonic microwave bandpass filters have a very low transmittance in the low-frequency regime, if a Gaussian pulse is applied to the photonic microwave bandpass filters, a UWB pulse would be generated. If the amplitude of the

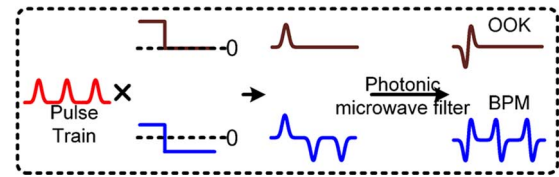

Fig. 5. Principle of the generation of OOK and BPM UWB signals using the photonic microwave filters.

Gaussian pulse is changed from positive to negative, the polarity of the UWB pulse would be inverted. As a result, OOK and BPM UWB signals can be obtained if the input Gaussian pulse train is multiplied by a nonreturn-to-zero (NRZ) signal. As shown in Fig. 5, if 0s in the NRZ signal are represented by dc, the photonic microwave bandpass filters would generate an OOK UWB signal. Otherwise, if positive and negative voltages are used to represent 1s and 0s, respectively, a BPM UWB signal would be achieved. A PPM UWB signal can be obtained if the Gaussian pulse train is passed through a variable delay module with the time delay controlled by a data signal, and then applied to the photonic microwave bandpass filters. To introduce time hopping (TH) which is used to reduce the large spectral lines in the spectrum [4], an additional variable delay module controlled by a random sequence is needed. In this paper, to concentrate on the transmission performance of BPM, OOK, and PPM signals in the UWBoF system, all the Gaussian pulse sequences are directly generated by the AWG for simplicity.

Fig. 6 shows the eye diagrams and the electrical spectra of the UWB signals generated by the PolM-based photonic microwave bandpass filter. The input Gaussian pulses are shaped to monocycle pulses by the filter. BPM, OOK, and PPM schemes without and with TH are successfully implemented on the optical UWB pulses. To further evaluate the performance of the modulation schemes, the eye diagrams and electrical spectra are measured when the optical powers applied to the PD are maintained identical, as shown in Fig. 6. As predicted in [14], the electrical spectra of the OOK and PPM signals consist of discrete and continuous spectral components, while that of a BPM signal contains only continuous spectral components. For the OOK signal, the discrete spectral lines are  $\sim 23$  dB higher than the continuous spectral components. For the PPM signals, both the discrete and the continuous spectral components are the power spectrum of a UWB pulse multiplied by a cosine-based function, which is periodic in frequency [14]. The frequency spacing between two adjacent notches is  $1/T_b$ , where  $T_b$  is the time shift of the pulses for 0 and 1 bit. In the experiment, we set  $T_b = 400$  ps, so the frequency spacing is 2.5 GHz. As can be seen from Fig. 6, the discrete lines at 1.25, 3.75, 6.25, 8.75, and 11.25 are fully suppressed. Meanwhile, the continuous spectral components around 2.5, 5, 7.5, and 10 GHz are greatly reduced. When TH is applied, the spectral lines in the electrical spectra of the PPM signals are reduced by 3–20 dB. Since the data information is mainly contained in the continuous spectral components, the power of the continuous spectral components has a direct relationship with the modulation efficiency, which also determines the receiver sensitivity. From Fig. 6, the BPM

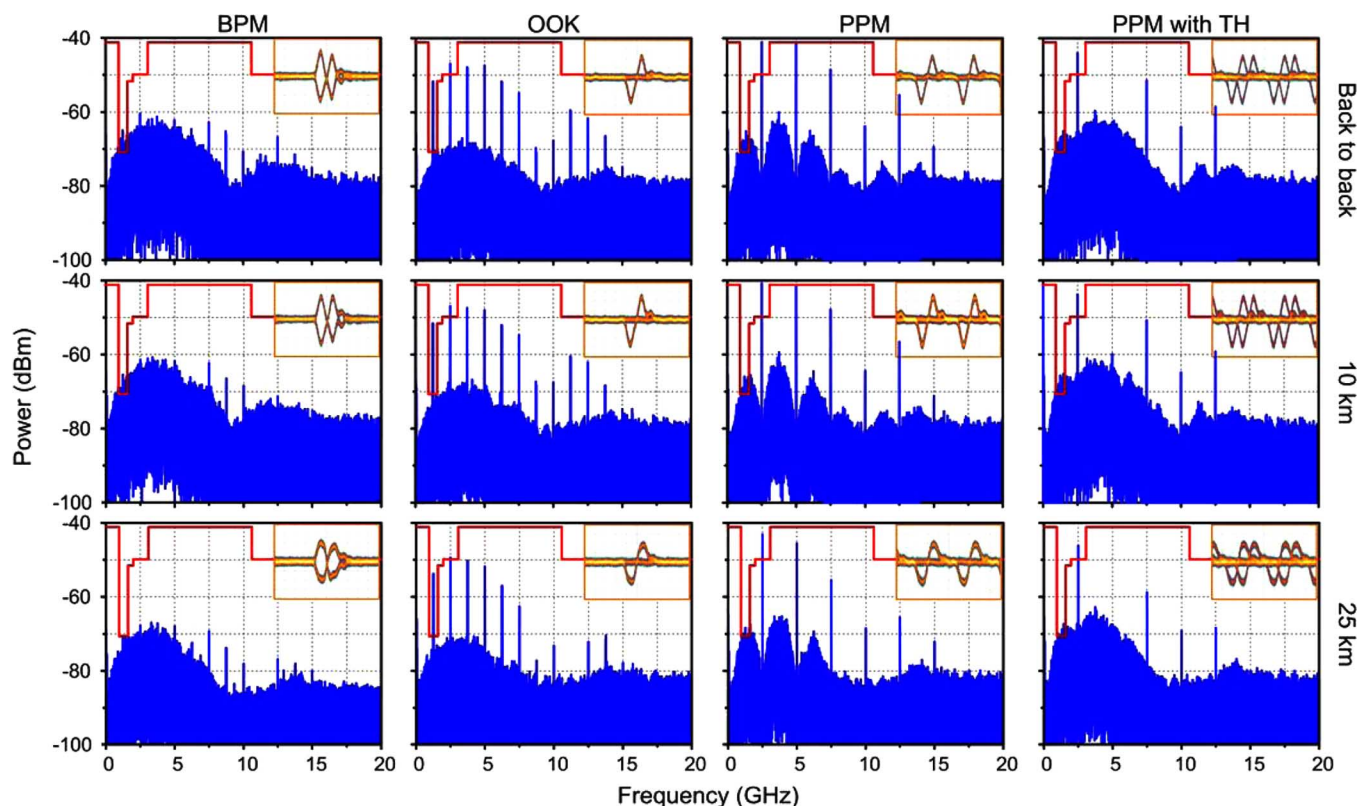

Fig. 6. Eye diagrams and the electrical spectra of the UWB signals generated by the PolM-based photonic microwave bandpass filter with back-to-back, 10 and 25 km SMF transmissions. The UWB signals are generated using the PolM-based photonic microwave filter. The resolution bandwidth of the spectra is 1 MHz and the span of the eye diagrams is 1 ns.

scheme provides the highest modulation efficiency. For the OOK signal, both the continuous and discrete spectral components are lower than those for the PPM signals. In practice, the peak power of a UWB signal should be adjusted such that the PSD is  $-41.3$  dBm to fit the FCC-specified spectral mask. In that way, the continuous spectral components of a PPM signal would be smaller than that of an OOK signal. Therefore, the PPM schemes have lower modulation efficiency. By applying TH, the modulation efficiency of the PPM scheme is significantly improved since the strong spectral lines are greatly suppressed. After 10 and 25 km SMF transmission, the high-frequency components of the UWB signals are reduced since the bandwidth of the filter decreases with the increase of the SMF length, as shown in Fig. 2.

The eye diagrams and the electrical spectra of the UWB signals generated by the PM-based photonic microwave bandpass filter are shown in Fig. 7. In this case, the input Gaussian pulses are shaped to doublet-like pulses. After 10 or 25 km SMF transmission, the total power of the UWB signals is decreased because the peak transmittance of the filter is reduced when the SMF length increases. However, the pulse shapes and spectral profiles of the UWB signals are kept unchanged since the frequency response in the frequency range from 3.1 to 10.6 GHz has an almost identical profile. Because a correlation receiver is very sensitive to the pulse shape of a UWB signal and the power difference can be overcome by placing an AGC in each ONU, a UWBoF system based this type of photonic microwave bandpass filter should have a better transmission performance than that in [5]–[12].

Since a correlation receiver is not available, in the experiment the performance of the UWBoF system is evaluated by downconverting the UWB signals from a center frequency of 2.5, 3.75, 5, 6.25, and 7.5 GHz to the baseband followed by a 1.25 Gb/s return-to-zero (RZ) signal receiver. Considering the major power of the UWB signal is around these frequencies, the BER performances of these downconverted signals would reveal the transmission performance of the UWBoF system. This method, however, cannot be used to evaluate UWB signals with PPM since the time-varied signals would cause synchronization problems to the RZ signal receiver. Fig. 8 shows the receiver sensitivity of the OOK and BPM UWB signals before transmission and after transmission over a 10 and 25 km SMF. The receiver sensitivity is the value of the optical power on which the BER of the UWB signal is  $10^{-9}$ . As can be seen from Fig. 8, a BER smaller than  $10^{-9}$  is achieved for all the signals. The BPM signals have a lower receiver sensitivity than the OOK signals [15]. The UWB signals generated by the PolM-based photonic microwave bandpass filter have a relatively poor transmission performance at the high-frequency regime. The power penalty of 10 km SMF transmission for the signals around 7.5 GHz is less than 0.4 dB, which is increased to 5 dB after 25 km SMF transmission, showing the high-frequency components are suppressed by the low-pass filtering effect of the fiber dispersion. From (9), we can calculate that the difference of the amplitude transfer functions of the PolM-based photonic microwave bandpass filter with 0 and 25 km SMF at 7.5 GHz is about 2.4 dB. Since the receiver sensitivity is a value of optical power, the difference of the

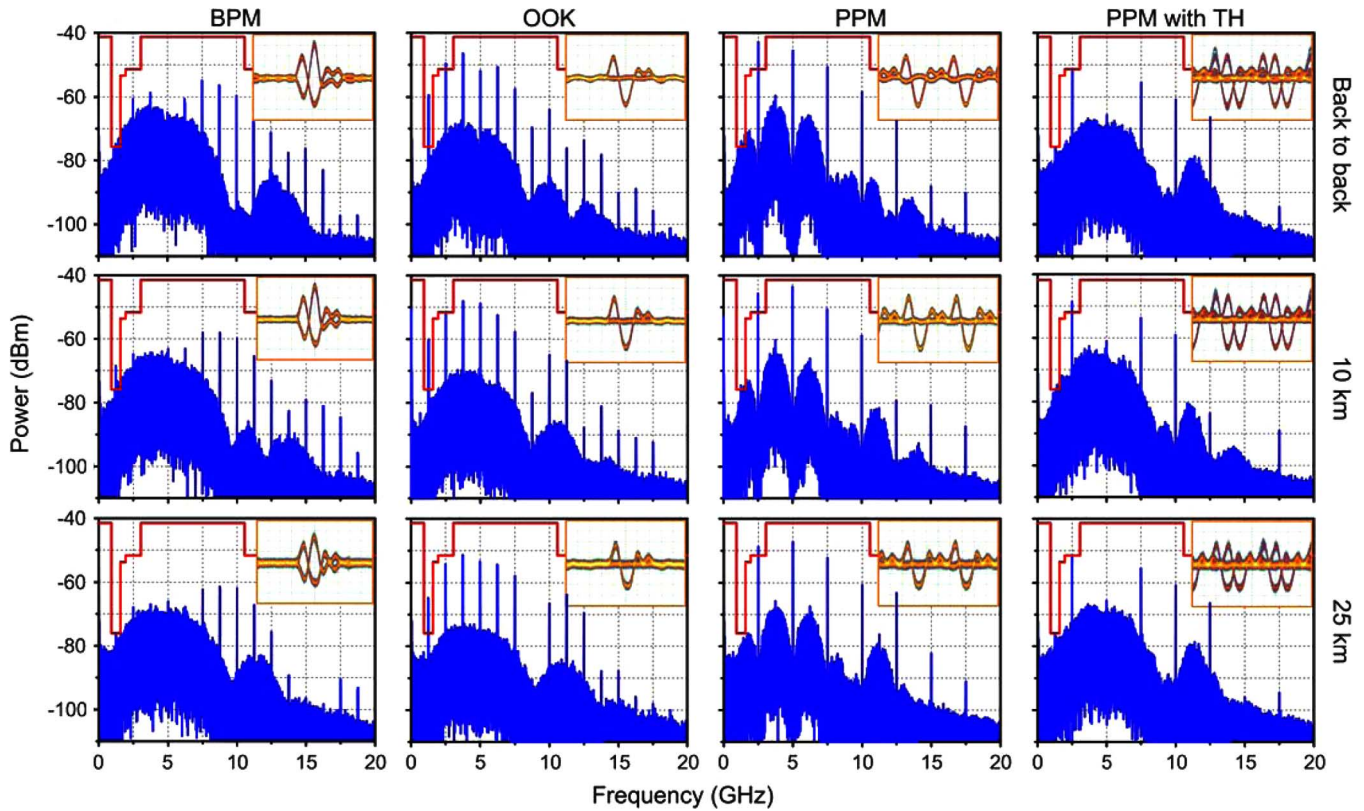

Fig. 7. Eye diagrams and the electrical spectra of the UWB signals generated by the PM-based photonic microwave bandpass filter before and after 10 and 25 km SMF transmission. The UWB signals are generated using the photonic microwave filter based on a PM. The resolution bandwidth of the spectra is 1 MHz and the span of the eye diagrams is 1 ns.

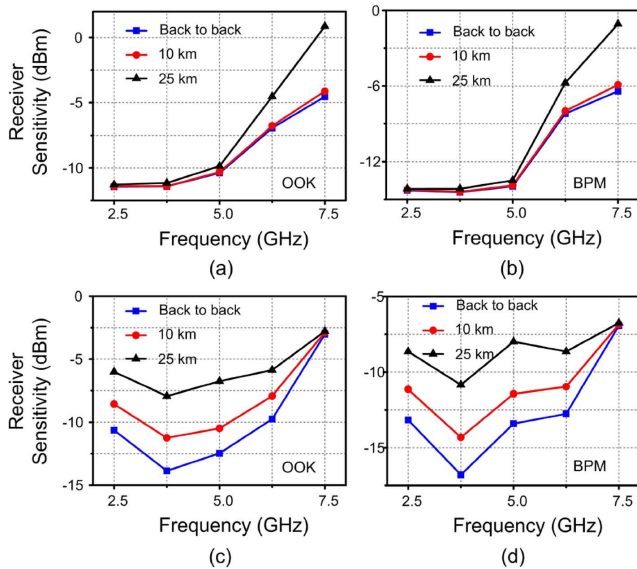

Fig. 8. Receiver sensitivity of the UWB signals after transmission over 0, 10, and 25 km SMF at a center frequency of 2.5, 3.75, 5, 6.25, and 7.5 GHz. (a), (b) UWB signals are generated by the photonic microwave bandpass filter based on a PolM. (c), (d) UWB signals are generated by the photonic microwave bandpass filter based on a PM.

corresponding receiver sensitivities should be two times of the difference of the amplitude transfer functions, i.e., 4.8 dB, very close to the measured result of 5 dB, showing that the theoretical results agree with experimental measurement very well. For the UWB signals generated by the PM-based

photonic microwave bandpass filter, the 10 and 25 km SMF transmissions introduce a power penalty of  $\sim 2.1$  and  $\sim 4.6$  dB for the signals around 3.75 GHz, respectively. As mentioned in the previous section, although the fiber dispersion does not change significantly the shape of the frequency response of the filter, it does decrease the peak transmittance of the filter, which leads to a power penalty. This power penalty can be easily reduced by placing an AGC in the ONU.

The wavelength independence of the operation is also verified for both the PolM- and PM-based filters. In the experiment, the wavelength of the light wave from the LD is tuned from 1535 to 1570 nm. No significant changes in the eye diagrams and the electrical spectra are observed. The independence of the operations on the optical wavelength would make the systems compatible with the WDM-PON architecture.

The stability of the system is also evaluated. To do so, we allow the systems to operate in a room environment for a period of 1 hour; no evident changes in the eye diagrams and electrical spectra are observed.

It should be noted that the UWB signals generated in this study exceeds the FCC mask in the spectral range from 0.96 to 3.1 GHz. In a practical UWBoF system, the UWB antennas would have a lower gain in the low-frequency region, so the spectral lines in the low-frequency range would be effectively suppressed by the UWB antennas. Because the powers of these low-frequency spectral lines are more than 5 dB lower than that of the spectral peak, the suppression of them does not cause significant power loss.



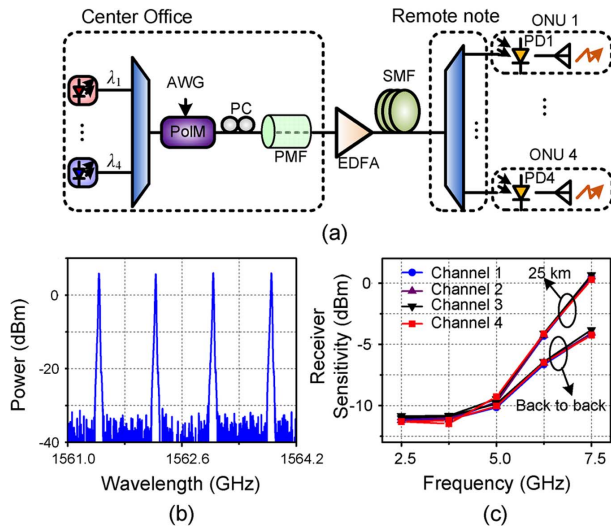

Fig. 9. Experimental demonstration of a four-channel WDM UWBoF system based on a PolM-based photonic microwave bandpass filter. (a) Schematic diagram; (b) the optical spectrum; (c) receiver sensitivity of the UW signals.

#### IV. MULTIPLE-CHANNEL ARCHITECTURES INCORPORATING THE UWBoF SYSTEM

Since the frequency response of the PolM- and PM-based photonic microwave bandpass filters is independent of the wavelength of the laser source, UWBoF systems based on the proposed filters should be compatible with the WDM-PON architecture. In this section, a WDM UWBoF system to provide four-channel wireless broadcasting services and a hybrid WDM-PON network to provide both wireless and wired services are experimentally studied.

Fig. 9(a) shows the schematic diagram of the four-channel UWBoF system. In the CO, four light waves from four LDs with an optical power of 2 dBm and a wavelength spacing of 0.8 nm are multiplexed to provide four WDM channels. These light waves are modulated at the PM by a 1.25 Gb/s OOK Gaussian sequence, which are transmitted through the PMF and the DE to generate 1.25 Gb/s optical OOK UW signals. The optical UW signals are amplified by an erbium-doped fiber amplifier (EDFA) and transmitted over a section of SMF with a length of 25 km to the remote note. In the remote note, the four channels are demultiplexed to each ONU, where the UW signals are detected by a PD and emitted to free space by a UW antenna. Fig. 9(b) shows the optical spectrum measured before demultiplexing. The four wavelengths are 1561.436, 1562.232, 1563.040, and 1563.838 nm. The receiver sensitivities of the UW signals in the four channels are also evaluated, with the results shown in Fig. 9(c). As can be seen, the four channels have a similar transmission performance. Comparing the receiver sensitivities with that in the single-channel UWBoF system shown in Fig. 8(a), no evident difference is found, which shows that a UWBoF system based on the proposed PolM- or PM-based photonic microwave bandpass filter is suitable for integration into a WDM-PON network.

To investigate the possibility to directly integrate UWBoF systems into a conventional WDM-PON network that provides wired service only, another four-channel optical network is constructed, as shown in Fig. 10(a). Two wavelengths (1561.436

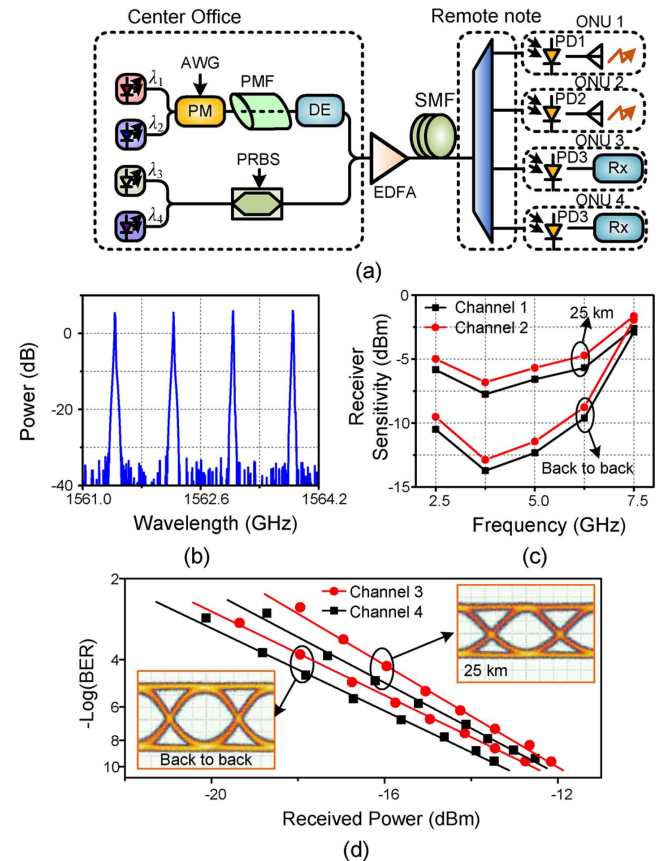

Fig. 10. Experimental demonstration of a hybrid WDM-PON network to provide both wireless and wired services. (a) Schematic diagram of the network incorporating a PM-based photonic microwave bandpass filter; (b) the optical spectrum; (c) receiver sensitivity of the UW signals; (d) BER curves of the 10 Gb/s wired signal.

nm and 1562.232 nm) are used to distribute two 1.25 Gb/s UW signals and the other two wavelengths (1563.040 nm and 1563.838 nm) are employed to distribute two 10 Gb/s wired signals. The 10 Gb/s wired signals are generated by modulating the light waves at an MZM by a PRBS with a word length of  $2^{31} - 1$ , and the 1.25 Gb/s UW signals are generated by sending an OOK Gaussian sequence to the PM-based photonic microwave bandpass filter. The wired signals and the UW signals are combined in the CO and then amplified by an EDFA. After transmission over 25 km SMF, the four channels are demultiplexed at the remote note to each ONU, where the wired signals are received by a 10 Gb/s receiver, and the UW signals are detected by a PD and emitted to free space by a UW antenna. The optical spectrum of the multiplexed signal is shown in Fig. 10(b). Due to the different insertion losses of the devices in the two paths, the four channels have different powers. Fig. 10(c) shows the receiver sensitivities of the UW signals. Again, the transmission performance is similar to that in the single-channel UWBoF system. However, the receiver sensitivities of Channel 2, which is closer to the channels with wired signals, are 1 dB larger than those of Channel 1. By turning off the two wired channels, the receiver sensitivities of Channel 2 are reduced by more than 0.6 dB while those of Channel 1 is kept almost unchanged, which shows that interferences from the wired channels exist. Since the receiver



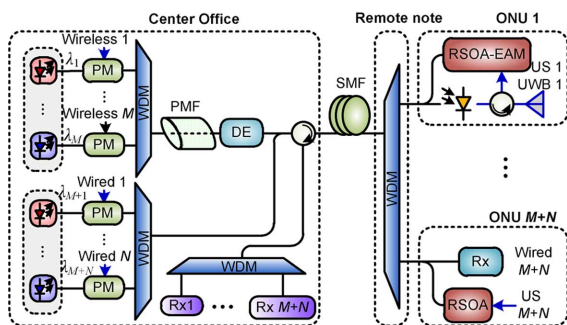

Fig. 11. Bidirectional WDM-PON network architecture with centralized light sources providing UWB and wired services. Rx: receiver; US: upstream UWB or Wired signal; RSOA: reflective semiconductor optical amplifier; EA: electroabsorption modulator; ONU: optical network unit.

sensitivity degradation for the signals before and after transmission is almost the same, the interferences should be originated from the imperfect optical filtering, by which part of the wired signals is leaked to the receiver of Channel 2. Fig. 10(d) shows the BER performance of the wired signals. A similar situation of Channel 2 is found in Channel 3, which is close to the UWB channels. The receiver sensitivity degradation is less than 0.8 dB. Although there are some interferences between the wired and wireless channels, the power penalties are small and can be further reduced by using optical filters with steep slopes. Thus, we can conclude that conventional WDM-PON networks can be directly upgraded to provide UWB services by incorporating the proposed photonic microwave bandpass filters.

In this work, the WDM systems with 0.8 nm spacing are tested. Since the IR-UWB signal only occupies a bandwidth of 10.6 GHz, and the 10 Gb/s wired signal spans up to 10 GHz, WDM systems with narrower (e.g., 25, 50 GHz) wavelength separation should also be able to operate with negligible inter-channel interference.

It should be noted that the system in Fig. 10(a) can also be easily upgraded to provide bidirectional services using a reflective semiconductor optical amplifier (RSOA) or an RSOA-electroabsorption modulator (EAM) operating in the saturation region [34]. Since the RSOA-EAM can support a remodulation bandwidth of more than 10 GHz (e.g., an SOA-EAM module made by CIP, Inc., Farmington, NM, has an 18 GHz remodulation bandwidth), the UWB upstream signals received by the antenna can be directly converted into optical signals at the SOA-EAM and delivered to the CO via optical fiber. Based on that system, a bidirectional WDM-PON network architecture with centralized light sources providing both UWB and wired services can be proposed, as shown in Fig. 11.

## V. CONCLUSION

A comprehensive study on UWBoF systems implemented by a PolM- or PM-based photonic microwave bandpass filter was performed. The frequency response of the two photonic microwave bandpass filters incorporating a length of SMF for signal distribution was theoretically studied. Based on the analysis, we concluded that UWB signals generated by a PolM-based photonic microwave bandpass filter could be distributed

over more than 20 km in SMF, and a UWBoF system constructed by a PM-based photonic microwave bandpass filter was not sensitive to fiber dispersion. An experiment was then performed. UWB signals with OOK, BPM, PPM, and PPM with TH were generated and transmitted through 10 and 25 km SMF. Eye diagrams, electrical spectra, and receiver sensitivity were measured and analyzed. To demonstrate the compatibility of the proposed UWBoF system with the WDM-PON architecture, a four-channel UWBoF broadcasting network as well as a hybrid WDM-PON network to provide both wireless and wired services was experimentally evaluated. From the study, we conclude that the conventional WDM-PON networks can be directly upgraded to provide UWB services by incorporating the proposed photonic microwave bandpass filters.

## REFERENCES

- [1] G. R. Aiello and G. D. Rogerson, "Ultra-wideband wireless systems," *IEEE Microw. Mag.*, vol. 4, no. 2, pp. 36–47, Jun. 2003.
- [2] D. Porcino and W. Hirt, "Ultra-wideband radio technology: Potential and challenges ahead," *IEEE Commun. Mag.*, vol. 41, no. 7, pp. 66–74, Jul. 2003.
- [3] M. Ghavami, L. B. Michael, and R. Kohno, *Ultra Wideband Signals and Systems in Communication Engineering*. West Sussex, U.K.: Wiley, 2004.
- [4] I. Oppermann, M. Hämäläinen, and J. Iinatti, *UWB Theory and Applications*. Chichester, U.K.: Wiley, 2004.
- [5] J. P. Yao, F. Zeng, and Q. Wang, "Photonic generation of ultrawideband signals," *J. Lightw. Technol.*, vol. 25, no. 11, pp. 3219–3235, Nov. 2007.
- [6] C. M. Tan, L. C. Ong, M. L. Yee, B. Luo, and P. K. Tang, "Direct transmission of ultra wide band signals using single mode radio-over-fiber system," in *Proc. Asia-Pacific Microw. Conf.*, Dec. 2005, vol. 1–5, pp. 1315–1317.
- [7] M. Abtahi, M. Mirshafiei, S. LaRochelle, and L. A. Rusch, "All-optical 500-Mb/s UWB transceiver: An experimental demonstration," *J. Lightw. Technol.*, vol. 26, no. 15, pp. 2795–2802, Aug. 2008.
- [8] T. B. Gibbon, X. B. Yu, R. Gamatham, N. G. Gonzalez, R. Rodes, J. B. Jensen, A. Caballero, and I. T. Monroy, "3.125 Gb/s impulse radio ultra-wideband photonic generation and distribution over a 50 km fiber with wireless transmission," *IEEE Microw. Wireless Compon. Lett.*, vol. 20, no. 2, pp. 127–129, Feb. 2010.
- [9] C. W. Chow, F. M. Kuo, J. W. Shi, C. H. Yeh, Y. F. Wu, C. H. Wang, Y. T. Li, and C. L. Pan, "100 GHz ultra-wideband (UWB) fiber-to-the-antenna (FTTA) system for in-building and in-home networks," *Opt. Exp.*, vol. 18, no. 2, pp. 473–478, Jan. 2010.
- [10] R. Llorente, T. Alves, M. Morant, M. Beltran, J. Perez, A. Cartaxo, and J. Marti, "Ultra-wideband radio signals distribution in FTTH networks," *IEEE Photon. Technol. Lett.*, vol. 20, no. 11, pp. 945–947, May 2008.
- [11] K. Prince, J. B. Jensen, A. Caballero, X. B. Yu, T. B. Gibbon, D. Zibar, N. Guerrero, A. V. Osadchii, and I. T. Monroy, "Converged wireline and wireless access over a 78-km deployed fiber long-reach WDM PON," *IEEE Photon. Technol. Lett.*, vol. 21, no. 17, pp. 1274–1276, Sep. 1, 2009.
- [12] S. L. Pan and J. P. Yao, "A photonic UWB generator reconfigurable for multiple modulation formats," *IEEE Photon. Technol. Lett.*, vol. 21, no. 19, pp. 1381–1383, Oct. 2009.
- [13] S. L. Pan and J. P. Yao, "Photonic generation of chirp-free UWB signals for UWB over fiber applications," in *Proc. Int. Top. Meet. Microw. Photon.*, 2009, pp. 100–103.
- [14] S. L. Pan and J. P. Yao, "UWB over fiber communications: Modulation and transmission," *J. Lightw. Technol.*, vol. 28, no. 16, pp. 2445–2455, Aug. 2010.
- [15] S. L. Pan and J. P. Yao, "Performance evaluation of UWB signal transmission over optical fiber," *IEEE J. Sel. Area Commun.*, vol. 28, no. 6, pp. 889–900, Aug. 2010.
- [16] *BPON*, ITU-T Recs. G.983; *GPON*, ITU-T Recs. G.984.
- [17] *Ethernet First Mile (EFM)*, IEEE Std. 802.3 ah; *10 GEPON* IEEE Std. 802.3 av.
- [18] K. Grobe and J. P. Elbers, "PON in adolescence: From TDMA to WDM-PON," *IEEE Commun. Mag.*, vol. 46, no. 1, pp. 26–34, Jan. 2008.

- [19] F. Ponzini, F. Cavaliere, G. Berrettini, M. Presi, E. Ciaramella, N. Calabretta, and A. Bogoni, "Evolution scenario toward WDM-PON," *J. Opt. Commun. Netw.*, vol. 1, no. 4, pp. C25–C34, Sep. 2009.
- [20] G. K. Chang, A. Chowdhury, Z. S. Jia, H. C. Chien, M. F. Huang, J. J. Yu, and G. Ellinas, "Key technologies of WDM-PON for future converged optical broadband access networks," *J. Opt. Commun. Netw.*, vol. 1, no. 4, pp. C35–C50, Sep. 2009.
- [21] J. Capmany, B. Ortega, and D. Pastor, "A tutorial on microwave photonic filters," *J. Lightw. Technol.*, vol. 24, no. 1, pp. 201–229, Jan. 2006.
- [22] J. P. Yao, "Microwave photonics," *J. Lightw. Technol.*, vol. 27, no. 3, pp. 314–335, Feb. 2009.
- [23] Q. Wang and J. P. Yao, "Switchable optical UWB monocycle and doublet generation using a reconfigurable photonic microwave delay-line filter," *Opt. Exp.*, vol. 15, no. 22, pp. 14667–14672, Oct. 2007.
- [24] H. Mu and J. P. Yao, "Polarity- and shape-switchable UWB pulse generation based on a photonic microwave delay-line filter with a negative tap coefficient," *IEEE Photon. Technol. Lett.*, vol. 21, no. 17, pp. 1253–1255, Sep. 2009.
- [25] Q. Wang, F. Zeng, S. Blais, and J. P. Yao, "Optical ultrawideband monocycle pulse generation based on cross-gain modulation in a semiconductor optical amplifier," *Opt. Lett.*, vol. 31, no. 21, pp. 3083–3085, Nov. 2006.
- [26] J. Li, B. P. P. Kuo, and K. K. Y. Wong, "Ultra-wideband pulse generation based on cross-gain modulation in fiber optical parametric amplifier," *IEEE Photon. Technol. Lett.*, vol. 21, no. 4, pp. 212–214, Feb. 2009.
- [27] M. Bolea, J. Mora, B. Ortega, and J. Capmany, "Optical UWB pulse generator using an N tap microwave photonic filter and phase inversion adaptable to different pulse modulation formats," *Opt. Exp.*, vol. 17, no. 7, pp. 5023–5032, Mar. 2009.
- [28] H. W. Chen, M. H. Chen, and S. Z. Xie, "Ultrawideband pulse generation using hybrid photonic microwave filters," *Opt. Eng.*, vol. 47, no. 4, p. 040504, Apr. 2008.
- [29] S. L. Pan and J. P. Yao, "A dispersion-insensitive UWB over fiber system based on a photonic microwave filter," presented at the Int. Top. Meet. Microw. Photon., Montreal, Canada, 2010, Paper WE3-5.
- [30] J. P. Yao and Q. Wang, "Photonic microwave bandpass filter with negative coefficients using a polarization modulator," *IEEE Photon. Technol. Lett.*, vol. 19, no. 9, pp. 644–646, May 2007.
- [31] J. Wang, F. Zeng, and J. P. Yao, "All-optical microwave bandpass filters implemented in a radio-over-fiber link," *IEEE Photon. Technol. Lett.*, vol. 17, no. 8, pp. 1737–1739, Aug. 2005.
- [32] J. D. Bull, N. A. F. Jaeger, H. Kato, M. Fairburn, A. Reid, and P. Ghanipour, "40 GHz electro-optic polarization modulator for fiber optic communication systems," *Proc. SPIE*, vol. 5577, pp. 133–143, 2004.
- [33] G. H. Smith, D. Novak, and Z. Ahmed, "Overcoming chromatic-dispersion effects in fiber-wireless systems incorporating external modulators," *IEEE Trans. Microw. Theory Tech.*, vol. 45, no. 8, pp. 1410–1415, Aug. 1997.
- [34] W. Lee, M. Y. Park, S. H. Cho, J. H. Lee, C. Kim, G. Jeong, and B. W. Kim, "Bidirectional WDM-PON based on gain-saturated reflective semiconductor optical amplifiers," *IEEE Photon. Technol. Lett.*, vol. 17, no. 11, pp. 2460–2462, Nov. 2005.

**Shilong Pan** (SM'06–M'09) received the B.S. and Ph.D. degrees in electronics engineering from Tsinghua University, Beijing, China, in 2004 and 2008, respectively.

In August 2008, he joined the Microwave Photonics Research Laboratory, School of Information Technology and Engineering, University of Ottawa, Ottawa, ON, Canada, as a Postdoctoral Research Fellow. His current research interests include fiber amplifiers and lasers, microwave photonics, optical signal processing and Terahertz wave generation.

Dr. Pan is a member of the Optical Society of America and the IEEE Photonics Society.

**Jianping Yao** (M'99–SM'01) received the Ph.D. degree in electrical engineering from the Université de Toulon, Toulon, France, in 1997.

He joined the School of Information Technology and Engineering, University of Ottawa, Ontario, Canada, in 2001, where he is currently a Professor, Director of the Microwave Photonics Research Laboratory, and Director of the Ottawa-Carleton Institute for Electrical and Computer Engineering. From 1999 to 2001, he held a faculty position with the School of Electrical and Electronic Engineering, Nanyang Technological University, Singapore. He holds a Yongqian Endowed Visiting Chair Professorship with Zhejiang University, China. He spent three months as an Invited Professor in the Institut National Polytechnique de Grenoble, France, in 2005. He has authored or co-authored more than 320 papers, including more than 180 papers in refereed journals and more than 140 papers in conference proceedings. His research has focused on microwave photonics, which includes all-optical microwave signal processing, photonic generation of microwave, millimeter-wave and terahertz, radio over fiber, ultrawideband over fiber, fiber Bragg gratings for microwave photonics applications, and optically controlled phased array antenna. His research interests also include fiber lasers, fiber-optic sensors and biophotonics.

Dr. Yao is an Associate Editor of the *International Journal of Microwave and Optical Technology*. He is on the Editorial Board of *IEEE TRANSACTIONS ON MICROWAVE THEORY AND TECHNIQUES*. He received the 2005 International Creative Research Award of the University of Ottawa. He was the recipient of the 2007 George S. Glinski Award for Excellence in Research. He was named University Research Chair in Microwave Photonics in 2007. He was a recipient of an NSERC Discovery Accelerator Supplements Award in 2008. He is a Registered Professional Engineer in Ontario. He is a Fellow of the Optical Society of America and a Senior Member of the IEEE Microwave Theory and Techniques Society.